

GOVERNMENT OF KHYBER PAKHTUNKHWA
DIRECTORATE GENERAL SMALL DAMS
IRRIGATION DEPARTMENT



NAME OF WORK: CONSTRUCTION OF SUMARI PAYAN DAM DISTRICT
KOHAT ADP NO. TADP NO. 2089/250193 (2025-26) (2025-26).

BIDDING DOCUMENTS

TENDER COST= RS. 2,667.433 (MILLION)

VOLUME-I

Notified vide: Notification No. S.R.O (31)/Vol:1-42/2025-26
Dated Peshawar the August 20, 2025

JUNE 2026

Deputy Director (P&C) Small Dams Division Kohat

BIDDING DOCUMENTS

VOLUME - I

1. Invitation for Bids
2. Instructions to Bidders
3. Bidding Data
4. Forms of Bid and Appendices to Bid
5. Part – I General Conditions of Contract
6. Part – II Particular Conditions of Contract
7. Specifications – Special Provisions
8. Specifications – Technical Provisions

VOLUME - II

BID DRAWINGS

TABLE OF CONTENTS

Description	Page
INVITATION FOR BIDS	li
INSTRUCTIONS TO BIDDERS	1
A. General	
IB.1 Scope of Bid	2
IB.2 Source of Funds	2
IB.3 Eligible Bidders	2
IB.4 One Bid Per Bidder	2
IB.5 Cost of Bidding	2
IB.6 Site Visit	3
B. Bidding Documents	
IB.7 Contents of Bidding Documents	3
IB.8 Clarification of Bidding Documents	4
IB.9 Amendment of Bidding Documents	4
C. Preparation of Bids	
IB.10. Language of Bid	5
IB.11 Documents Accompanying the Bid	5
IB.12 Bid Prices	7
IB.13 Currencies of Bid and Payment	8
IB.14 Bid Validity	9
IB.15 Bid Security	9
IB.16 Alternate Proposals by Bidder	9
IB.17 Pre-Bid Meeting	10
IB.18 Format and Signing of Bid	11
D. Submission of Bids	
IB.19 Sealing and Marking of Bids	12
IB.20 Deadline for Submission of Bids	12
IB.21 Late Bids	13
IB.22 Modification, Substitution and Withdrawal of Bids	13

E.	Bid Opening and Evaluation		
	IB.23 Bid Opening		14
	IB.24 Process to be Confidential		15
	IB.25 Clarification of Bids		16
	IB.26 Examination of Bids and Determination of Responsiveness		16
	IB.27 Correction of Errors		17
	IB.28 Evaluation and Comparison of Bids		17
F.	Award of Contract		
	IB.29 Award		18
	IB.30 Procuring Entity's Right to Accept any Bid and to Reject any or all Bids		19
	IB.31 Notification of Award		19
	IB.32 Performance Security		19
	IB.33 Signing of Contract Agreement		20
	IB.34 General Performance of the Bidders		20
	IB.35 Integrity Pact		20
	IB.36 Instructions Not Part of Contract		20
	BIDDING DATA		28
	APPENDICES TO BID		37
	FORM OF BID		
	Appendix-A to Bid	: Special Stipulations	41
	Appendix-B to Bid	: Foreign Currency Requirements	43
	Appendix-C to Bid	: Price Adjustment (Under Clause 70)	44
	Appendix-D to Bid	: Bill of Quantities	45
	Appendix-E to Bid	: Proposed Construction Schedule	49
	Appendix-F to Bid	: Method of Performing the Work	50
	Appendix-G to Bid	: List of Major Equipment – Related Items	51
	Appendix-H to Bid	: Construction Camp and Housing Facilities	53
	Appendix-I to Bid	: List of Subcontractors	54
	Appendix-J to Bid	: Estimated Progress Payments	55
	Appendix-K to Bid	: Organization Chart of the Supervisory Staff and Labour	56
	Appendix-L to Bid	: Integrity Pact	57
	Appendix-M to Bid	: Financial	59
	Appendix-N to Bid	: Performance	60
	FORMS		
	BID SECURITY		64
	PERFORMANCE SECURITY		66
	CONTRACT AGREEMENT		68
	MOBILIZATION ADVANCE GUARANTEE/BOND		70

PART-I: GENERAL CONDITIONS OF CONTRACT	71
PART-II: PARTICULAR CONDITIONS OF CONTRACT	73
SPECIFICATIONS - SPECIAL PROVISIONS	102
SPECIFICATIONS - TECHNICAL PROVISIONS	119
DRAWINGS	

INVITATION FOR BID

DIRECTORATE GENERAL SMALL DAMS
GOVT. OF KHYBER PAKKHTUNKHWA IRRIGATION DEPARTMENT

NOTICE INVITING E-BIDDING

(Single Stage Two Envelope through E-Pak Acquisition & Disposal System)

- I- The Director General, Small Dams Peshawar through Deputy Director (P&C), Small Dam Division Kohat intends to invite Electronic Bids from Contractor/Firms in accordance with KPPRA Procurement Rules 2014, up-to-date on Single Stage Two Envelopes Procedure for the following work.

<i>Sr No.</i>	<i>Name of Project</i>	<i>E/ Money (Rs. M)</i>	<i>Enlistment Category</i>	<i>Last date & time for submission of Bids</i>	<i>Date & time for Opening of Tech: Bids</i>	<i>Completion period</i>
1	2	3	4	5	6	7
1	Construction of Sumari Payan Dam District Kohat	Rs. 53.35	C-B And PK-CB	13/07/2026 (1200 Hrs)	13/07/2026 (1230 Hrs)	36 Months

Bidding Documents, Instructions to the bidders and Evaluation Criteria can be downloaded from EPADS (kp.eprocure.gov.pk) as well as from Irrigation Department website www.irrigation.gkp.pk.

- II- The bidders should submit their E-Bids as per KPPRA Notifications up-to-date.
 III- The bidders shall upload their Technical and Financial proposals/Bids on E-PADS as per above mentioned deadline.
 IV- The validity of Bids shall be 120 days.
 V- Pre-Bid meeting will be held in the office of the Director General, Small Dams Peshawar on 07/07/2026 at 1400 Hours.
 VI- The bidders shall submit Bid Security or Additional Security, if any, in shape of CDR from schedule bank, to the Procuring Entity, through a leading courier service along-with letter on its letter head before the deadline for submission of bids, receive acknowledgement and shall also upload Complete Detail of Bid Security or (Additional Security, if any) along-with E-Bid on E-Pak Acquisition and Disposal System (EPADS) otherwise the bid shall be considered as “**Non-Responsive**”.
 VII- The required documents shall be neatly signed, stamped by Controlling Head of the firm/Authorized Representative, scanned and uploaded on EPADS.
 IX- Incomplete/conditional bids, unattested cutting/overwriting/disfigured document shall be considered as “**Non Responsive**”.
 X- All bidders are required to be registered with Khyber Pakhtunkhwa Revenue Authority as per Khyber Pakhtunkhwa Finance Act 2013 Act No. XXI of 2013.
 XI- The Financial Bids of the Technically Qualified Bidders shall be opened after approval of Technical Evaluation by the Competent Authority.
 XII- Electronic Bidding shall be done on “Above/Below System” on Engineer Estimate. Only two digits after the decimal point shall be considered for evaluation.
 XIII- The procuring entity shall disqualify a contractor if it finds, at any time, that the information submitted by him concerning his qualification as contractor was false and materially inaccurate or incomplete.
 XIV- The bidders shall provide a Notary Public attested affidavit for “No Litigation” and “No blacklisting” of the firm, otherwise the firm shall be considered as “**Non Responsive**”.
 XV- The Procuring Entity (P.E) reserves the right to reject any or all bids, with cogent and valid reasons.
 XVI- Venue of Bid Opening is office of the Directorate General, Small Dams Peshawar.

Deputy Director (P&C)
Small Dams Division Kohat

**Address: Directorate General Small Dams, Plot No. 27, Street No. 12, Sector E-8, Phase-VII,
Hayatabad Peshawar. Phone No. 091-9219555**

TERMS AND CONDITIONS:

1. Bid Soliciting Documents containing Instructions to Bidders, advertisement for Notice Inviting Bids and required forms to be filled by the bidders can be downloaded from the official websites of Irrigation Department Khyber Pakhtunkhwa (www.irrigation.gkp.pk) and KPPRA (www.kppra@gov.pk).
2. Technical Proposal should accompany with attested photocopies (in original) of the following, otherwise the technical proposal shall be **“Non Responsive”**.
 - a- Bid security of 2% (two percent) of the estimated cost amounting to **Rs. 53.35 million** in the shape of Call Deposit (in original) in the name of Deputy Director (P&C) Small Dams Division Kohat, the details of which shall be uploaded on e-PADS. The E-Bidders who quote their bids/rates more than 20% below the Engineer’s estimate shall submit an additional security in the form of call deposit in the name of Deputy Director (P&C) Small Dams Division Kohat, the details of which shall also be uploaded on e-PADS.
 - b- Enlistment Order / Renewal with Irrigation Department in the required category for CFY 2025-26 (Attested Copy).
 - c- Registration with Khyber Pakhtunkhwa Revenue Authority under the Khyber Pakhtunkhwa Finance Act 2018 (Khyber Pakhtunkhwa Act, XXI of 2013).
 - d- National Identity Card of the controlling Head of the Bidding firm (CNIC Photocopy).
 - e- Valid Pakistan Engineering Council Registration for the current calendar year.
 - f- Form H of the Company/Firm.
 - g- Documents required for technical evaluation must be attested by an officer not less than the rank of Executive Engineer/Deputy Director and experience certificates must be provided in original, signed by the Deputy Director/Executive Engineer (concerned) addressed to the Director General, Small Dams Peshawar, with their Phone Number and email duly mentioned on the letter head. Personal capabilities, equipment capabilities through affidavit duly attested by Notary Public must be provided on E-Stamp paper.
3. The bidders shall provide a Notary Public attested affidavit for “No Litigation” and “No blacklisting” of the firm, otherwise the firm shall be considered as **“Non Responsive”**.
4. The technical proposal containing all requirements/documents shall be duly numbered and signed in original with separators/annexures to support the technical bids.
5. Technical Evaluation will be carried out in accordance with criteria mentioned in these bidding documents.
6. The participating bidder who does not qualify the **Mandatory Eligibility Criteria** to bid as mentioned at Section 37.1 (A) shall be considered as **non-responsive**.
7. Financial bidding shall be carried out through E-bidding (**E-PADS**) on **“Above / Below System”** on BOQ / Engineer’s Estimate, based on the MRS applicable and NSI. Only two digits after the decimal point shall be considered for evaluation purpose.
8. Conditional Bids shall not be considered for evaluation.
9. If the evaluated electronic bid costs of two or more than two bidders are equal then the successful bidder will be declared through draw/toss.
10. Technical Proposals/Bids will be opened after 30-minutes of closing/deadline time in the presence of bidders/authorized representatives, who may choose to be present.
11. All the prevailing KPPRA Act / Rules, taxes/duties and other Government Notifications issued till closing date will be applicable.
12. The contractors quoting their bids more than 10% below upto 20% below on Engineers’ Estimate shall submit along with their bids 8% Additional Security of Engineer’s Estimated cost in addition to 2% bid security. If the bid is not accompanied with the required amount of

additional security then it will be considered as non-responsive and the 2% bid security shall be forfeited in favor of Government and the second lowest bidder and so on will be considered accordingly.

13. Similarly, a contractor quoting bid more than 20% below shall submit with his bid an additional security on Engineer's Estimated cost equal to the differential amount of submitted bid and Engineers' Estimate along with detailed rate analysis. In case of more than 20% below bids, if the bid is not accompanied by the detailed rate analysis and / or required amount of additional security, then the said bid shall be considered as non-responsive. All the securities submitted along with such non-responsive bid shall be forfeited in favor of Government and the 2nd lowest bidder and so on will be considered accordingly.
14. In case detailed rate analysis submitted with the bids is, in view of the Procuring Entity, not convincing, the Head of the Procuring Entity may declare such bid as nonresponsive without any forfeiture of bid securities and record reasons thereof.
15. The procuring entity may offer the contract to next lowest bidder after due diligence in the context of financial difference between such two bids or may advertise procurement opportunity afresh.
16. Call Deposit of schedule Banks shall be acceptable. **No Bank Cheque or Pay Order shall be acceptable.**
17. The Competent Authority reserves the right to Accept / Reject any or all bids at any time prior to acceptance of a bid as per Para 47(i) of KPPRA Rules 2014.
18. Bid Securities of 1st, 2nd & 3rd lowest bidders shall be retained till signing of the Contract Agreement with the lowest responsive bidder.
19. After commencement of work by the successful bidder, the additional security shall be released to the bidders in four instalments i.e., 25% to be released after completing 25% of the Project and so on.
20. Successful bidder should sign the Agreement with the Department within 28-days after issuance of LOA and after that work order will be issued.
21. The interested Firms/Contractors may obtain clarification regarding bid solicitation documents during office hours on any working day from the Office of the Deputy Director (P&C) Small Dams Division Kohat.

**DEPUTY DIRECTOR
(P&C) SMALL DAMS DIVISION KOHAT**

**Address: (P&C) Small Dams Division Kohat, Irrigation Colony, Charbagh, KDA Road, Kohat.
Phone No. 0922-515343**

INSTRUCTIONS

TO

BIDDERS

INSTRUCTIONS TO BIDDERS

A. GENERAL

IB.1 Scope of Bid

- 1.1 The Procuring Entity / Employer as defined in the Bidding Data hereinafter called “the Procuring Entity / Employer” wishes to receive bids for the construction and completion of works as described in these Bidding Documents, and summarized in the Bidding Data hereinafter referred to as the “Works”.
- 1.2 The successful bidder will be expected to complete the Works within the time specified in Appendix-A to Bid.
- 1.3 Throughout these bidding documents, the terms ‘bid’ and ‘tender’ and their derivatives (bidder / tenderer, bid / tender, bidding / tendering etc.) are synonymous.

IB.2 Source of Funds

- 2.1 The expenditure on this project/scheme will be met from the Public Funds of the Provincial Government of Khyber Pakhtunkhwa (GoKP), as defined in Rule-2(l)(l) of the KP Public Procurement Rules, 2014 and it is intended that part of these Public Funds will be applied to eligible payments under the Contract, for which these Bid Solicitation Documents are issued.

IB.3 Eligible Bidders

- 3.1 This Invitation for Bids is open to all bidders meeting the following requirements:
 - a. Duly licensed by the Pakistan Engineering Council (PEC) in the required category as per NIT and criteria mentioned in the bidding documents.
 - b. Is neither associated, nor has been associated, directly or indirectly, with the Consultants or any other entity that has prepared the design, specifications, and other documents for the Project/Scheme or being proposed for any position in the Project Management.
 - c. duly registered with the Khyber Pakhtunkhwa Revenue Authority for the purpose of Sales Tax on Services.
- 3.2 A bidder having a conflict of interest will be declared as non-responsive if the bidder has a close business relationship with the Procuring Entity’s professional personnel, who directly or indirectly involved in any part of: (i) the preparation of the bidding documents for the Works, (ii) the Bid evaluation or (iii) the supervision of such Works.

IB.4 One Bid per Bidder

4.1 Each bidder shall submit only one bid either by himself, or as a partner in a joint venture. A bidder who submits or participates in more than one bid (other than alternatives pursuant to Clause IB.16) will be disqualified.

IB.5 Cost of Bidding

5.1 The bidders shall bear all costs associated with the preparation and submission of their respective bids and the Procuring Entity / Employer will in no case be responsible or liable for those costs, regardless of the conduct or outcome of the bidding process.

IB.6 Site Visit

6.1 The bidders are advised to visit and examine the Site of Works and its surroundings and obtain for themselves on their own responsibility all information that may be necessary for preparing the bid and entering into a contract for construction of the Works. All cost in this respect shall be at the bidder's own expense.

6.2 The bidders and any of their personnel or agents will be granted permission by the Procuring Entity / Employer to enter upon his premises and lands for the purpose of such inspection, but only upon the express condition that the bidders, their personnel and agents, will release and indemnify the Procuring Entity / Employer, his personnel and agents from and against all liability in respect thereof and will be responsible for death or personal injury, loss of or damage to property and any other loss, damage, costs and expenses incurred as a result of such inspection.

B. BIDDING DOCUMENTS**IB.7 Contents of Bidding Documents**

7.1 The Bidding Documents, in addition to invitation for bids, are those stated below and should be read in conjunction with any Addenda issued in accordance with Clause IB.9.

1. Instructions to Bidders.
2. Bidding Data.
3. Conditions of Contract, Part-I - General Conditions
4. General Conditions of Contract, Part-I (GCC)

5. Particular Conditions of Contract, Part-II (PCC)
 6. Specifications – Special Provisions
 7. Specifications - Technical Provisions.
 8. Form of Bid & Appendices to Bid.
 9. Bill of Quantities (Appendix-D to Bid).
 10. Form of Bid Security.
 11. Form of Contract Agreement.
 12. Forms of Performance Security and Mobilization Advance Guarantee/Bond.
 13. Drawings.
- 7.2 The bidders are expected to examine carefully the contents of all the above documents. Failure to comply with the requirements of bid submission will be at the Bidder's own risk. Pursuant to Clause IB.26, bids which are not substantially responsive to the requirements of the Bidding Documents will be rejected.

IB.8 Clarification of Bidding Documents

- 8.1 Any prospective bidder requiring any clarification (s) in respect of the Bid Solicitation Documents may notify the Procuring Entity in writing at the Procuring Entity's address indicated in the Invitation for Bids. The Procuring Entity will respond to any request for clarification raised during the pre bid meeting scheduled to be held on 05-01-2026.

IB.9 Amendment of Bidding Documents

- 9.1 At any time prior to the deadline for submission of bids, the Procuring Entity / Employer may, for any reason, whether at his own initiative or in response to a clarification requested by a prospective bidder, modify the Bidding Documents by issuing addendum.
- 9.2 Any addendum thus issued shall be part of the Bidding Documents pursuant to Sub-Clause 7.1 hereof and shall be communicated in writing to all purchasers of the Bidding Documents. Prospective bidders shall acknowledge receipt of each addendum in writing to the Procuring Entity / Employer.

- 9.3 To afford prospective bidders reasonable time in which to take an addendum into account in preparing their bids, the Procuring Entity / Employer may extend the deadline for submission of bids in accordance with Clause IB.20.

C. PREPARATION OF BIDS

IB.10 Language of Bid

- 10.1 The bid, all correspondence, and documents related to the bid exchanged by a bidder and the Procuring Entity shall be in the bid language stipulated in the Bidding Data and Special Conditions of Contract

IB.11 Documents Accompanying the Bid

- 11.1 Each bidder shall:
- (a) Submit a written power of attorney authorizing the signatory of the bid to act for and on behalf of the bidder;
 - (b) (update the information indicated and listed in the Bidding Data and previously submitted with the application for prequalification, and continue to meet the minimum criteria set out in the prequalification documents which as a minimum, would include the following:
 - i. Evidence of access to financial resources along with average annual construction turnover.
 - ii. Financial predictions for the current year and the two following years including the effect of known commitments.
 - iii. Work commitments since prequalification.
 - iv. Current litigation information; and
 - v. Availability of critical equipment.and
 - (c) furnish a technical proposal taking into account the various Appendices to Bid specially the following:
 - Appendix-E to Bid Proposed Construction Schedule
 - Appendix-F to Bid Method of Performing the Work
 - Appendix-G to Bid List of Major Equipment
 - Appendix-K to Bid Organization Chart for Supervisory Staff and other pertinent information such as mobilization program etc;
- 11.2 Bids submitted by a joint venture of two (2) or more firms shall comply with

the following requirements:

- (a) The bid and in case of a successful bid, the Form of Contract Agreement shall be signed so as to be legally binding on all partners;
- (b) One of the joint venture partners shall be nominated as being in charge; and this authorization shall be evidenced by submitting a power of attorney signed by legally authorized signatories of all the joint venture partners;
- (c) The partner-in-charge shall always be duly authorized to deal with the Employer regarding all matters related with and/or incidental to the execution of Works as per the terms and Conditions of Contract and in this regard to incur any and all liabilities, receive instructions, give binding undertakings and receive payments on behalf of the joint venture;
- (d) All partners of the joint venture shall at all times and under all circumstances be liable jointly and severally for the execution of the Contract in accordance with the Contract terms and a statement to this effect shall be included in the authorization mentioned under Sub-Para (b) above as well as in the Form of Bid and in the Form of Contract Agreement (in case of a successful bid); and
- (e) A copy of the agreement entered into by the joint venture partners shall be submitted with the bid stating the conditions under which it will function, its period of duration, the persons authorized to represent and obligate it and which persons will be directly responsible for due performance of the Contract and can give valid receipts on behalf of the joint venture, the proportionate participation of the several firms forming the joint venture, and any other information necessary to permit a full appraisal of its functioning. No amendments / modifications whatsoever in the joint

venture agreement shall be agreed to between the joint venture partners without prior written consent of the Employer.

- 11.3 Bidders shall also submit proposals of work methods and schedule, in sufficient detail to demonstrate the adequacy of the Bidders' proposals to meet the technical specifications and the completion time referred to in Sub-Clause 1.2 hereof.

IB.12 Bid Prices

- 12.1 Unless stated otherwise in the Bidding Documents, the Contract shall be for the whole of the Works as described in Sub-Clause 1.1 hereof, based on the unit rates and / or prices submitted by the bidder.
- 12.2 The bidders shall fill in rates and prices for all items of the Works described in the Bill of Quantities. Unit rate offered for an item shall be considered upto two significant decimals places for evaluation purposes. Items against which no rate or price is entered by a bidder will not be paid for by the Procuring Entity when executed and shall be deemed covered by rates and prices for other items in the Bill of Quantities. Corrections in rates and prices, if any, shall be made by crossing out, initialing, dating and re-writing.
- 12.3 All duties, taxes and other levies payable by the Contractor under the Contract, or for any other cause, as on the date 28 days prior to the deadline for submission of bids shall be included in the rates and prices and the total Bid Price submitted by a bidder.
- Additional / reduced duties, taxes and levies due to subsequent additions or changes in legislation shall be reimbursed / deducted as per Sub-Clause 70.2 of the General Conditions of Contract Part-I.
- 12.4 The rates and prices, resulting from the bidders quoted SINGLE PERCENTAGE RATE, with two digits after the decimal point, "ABOVE / BELOW / AT PAR" of the Engineer's Estimated cost, are subject to adjustment during the performance of the Contract in accordance with the provisions of Clause 70 of the Conditions of Contract. Price adjustments will be accomplished in line with the weightages/coefficients quantified by the Procuring Entity in Appendix-C to Bid.

IB.13 Currencies of Bid and Payment

- 13.1 The unit rates and the prices shall be quoted by the bidder entirely in Pak rupees.
- A bidder expecting to incur expenditures in other currencies for inputs to the Works supplied from outside the Procuring Entity/Procuring Entity / Employer's country (referred to as the "Foreign Currency Requirements") shall indicate the same in Appendix-B to Bid. The proportion of the Bid Price (excluding Provisional Sums) needed by him for the payment of such Foreign Currency Requirements either
- (i) Entirely in the currency of the Bidder's home country or, (ii) at the bidder's option, entirely in Pak rupees
- provided always that a bidder expecting to incur expenditures in a currency or currencies other than those stated in (i) and (ii) above for a portion of the foreign currency requirements, and wishing to be paid accordingly, shall indicate the respective portions in his bid.
- 13.2 The rates of exchange to be used by the bidder for currency conversion shall be the TT&OD Selling Rates published or authorized by the State Bank of Pakistan prevailing on the date 28 days prior to the deadline for submission of bids.
- For the purpose of payments, the exchange rates used in bid preparation shall apply for the duration of the Contract.

IB.14 Bid Validity

- 14.1 Bids shall remain valid for the period stipulated in the Bidding Data after the Date of Bid Opening specified in Clause IB.23.
- 14.2 In exceptional circumstances, prior to expiry of the original bid validity period, the Procuring Entity / Employer may request that the bidders extend the period of validity for a specified additional period which shall in no case be more than the original bid validity period. The request and the responses thereto shall be made in writing. A bidder may refuse the request without forfeiting his Bid Security. A bidder agreeing to the request will not be required or permitted to modify his bid, but will be required to extend the validity of his Bid Security for the period of the extension, and in compliance with Clause IB.14 in all respects. The bidder shall bear all costs

to be incurred on such extensions.

IB.15 Bid Security

- 15.1 Each bidder shall furnish, as part of his bid, a Bid Security in the amount stipulated in the Bidding Data in Pak Rupees or an equivalent amount in a freely convertible currency.
- The Bids security shall be submitted from the account of the firm/bidder/contractor who submits the bid, vide KPPRA Notification No. KPPRA/M&E/Esst:/1-12/2017-18 dated April 05, 2018.
- 15.2 The Bid Security shall be, in the form of Deposit at Call issued by a Scheduled Bank in Pakistan, in favor of the Procuring Entity / Employer valid for a period 28 days beyond the Bid Validity date.
- 15.3 Any bid not accompanied by an acceptable Bid Security shall be rejected by the Procuring Entity / Employer as non-responsive.
- 15.4 The bid securities of unsuccessful bidders except 1st, 2nd & 3rd will be returned as promptly as possible, but not later than 28 days after the expiration of the period of Bid Validity.
- 15.5 The Bid Security of the successful bidder will be returned when the bidder has furnished the required Performance Security and signed the Contract Agreement. The Bid Security may be adjusted by the Procuring Entity / Employer as part of the Performance Security.
- 15.6 The Bid Security may be forfeited:
- (a) If the bidder withdraws his bid during the period of bid validity except as provided in Sub-Clause 22.1;
 - (b) If the bidder does not accept the correction of his Bid Price pursuant to Sub-Clause 27.2 hereof; or
 - (c) In the case of successful bidder, if he fails within the specified time limit to:
 - (i) Furnish the required Performance Security; or
 - (ii) Sign the Contract Agreement.

IB.16 Alternate Proposals by Bidder

- 16.1 Should any bidder consider that he can offer any advantages to the Procuring Entity / Employer by a modification to the designs, specifications or other conditions, he may, in addition to his bid to be submitted in strict compliance with the Bidding Documents, submit any Alternate Proposal(s) containing (a) relevant design calculations; (b) technical specifications; (c) proposed construction methodology; and (d) any other relevant details / conditions, provided always that the total sum entered on the Form of Bid shall be that which represents complete compliance with the Bidding Documents.
- 16.2 Alternate Proposal(s), if any, of the lowest evaluated responsive bidder only may be considered by the Procuring Entity / Employer as the basis for the award of Contract to such bidder.

IB.17 Pre-Bid Meeting

- 17.1 The Procuring Entity / Employer may, on his own motion or at the request of any prospective bidder(s), hold a pre-bid meeting to clarify issues and to answer any questions on matters related to the Bidding Documents. The date, time and venue of pre-bid meeting, if convened, is as stipulated in the Bidding Data. All prospective bidders or their authorized representatives shall be invited to attend such a pre-bid meeting.
- 17.2 The bidders are requested to submit questions, if any, in writing so as to reach the Procuring Entity / Employer not later than seven (7) days before the proposed pre-bid meeting.
- 17.3 Minutes of the pre-bid meeting, including the text of the questions raised and the replies given, will be transmitted without delay to all purchasers of the Bidding Documents. Any modification of the Bidding Documents listed in Sub-Clause 7.1 hereof which may become necessary as a result of the pre-bid meeting shall be made by the Procuring Entity / Employer exclusively through the issue of an Addendum pursuant to Clause IB.9 and not through the minutes of the pre-bid meeting.
- 17.4 Absence at the pre-bid meeting will not be a cause for disqualification of a bidder.

IB.18 Format and Signing of Bid

- 18.1 Bidders are particularly directed that the amount entered on the Form of Bid shall be for performing the Contract strictly in accordance with the Bidding Documents.
- 18.2 All appendices to Bid are to be properly completed and signed.
- 18.3 No alteration is to be made in the Form of Bid nor in the Appendices thereto except in filling up the blanks as directed. If any such alterations be made or if these instructions be not fully complied with, the bid may be rejected.
- 18.4 Each bidder shall prepare by filling out the forms completely and without alterations one (1) original and number of copies, specified in the Bidding Data, of the documents comprising the bid as described in Clause IB.7 and clearly mark them "ORIGINAL" and "COPY" as appropriate. In the event of discrepancy between them, the original shall prevail.
- 18.5 The original and all copies of the bid shall be typed or written in indelible ink (in the case of copies, Photostats are also acceptable) and shall be signed by a person or persons duly authorized to sign on behalf of the bidder pursuant to Sub- Clause 11.1(a) hereof. All pages of the bid shall be initialed and stamped by the person or persons signing the bid.
- 18.6 The bid shall contain no alterations, omissions or additions, except to comply with instructions issued by the Procuring Entity, or as are necessary to correct errors made by the bidder, in which case such corrections shall be initialed by the person or persons signing the bid.
- 18.7 Bidders shall indicate in the space provided in the Form of Bid their full and proper addresses at which notices may be legally served on them and to which all correspondence in connection with their bids and the Contract is to be sent.
- 18.8 Bidders should retain a copy of the Bidding Documents as their file copy.

D. SUBMISSION OF BIDS**IB.19 Sealing and Marking of Bids**

- 19.1 Each bidder shall submit his bid as under:
- (a) ORIGINAL Bid shall be put in envelope and marked as such.
 - (b) The envelope containing the ORIGINAL bid will be put in one sealed

envelope and addressed / identified as given in Sub- Clause 19.2 hereof.

- 19.2 The inner and outer envelopes shall:
- (a) Be addressed to the Procuring Entity / Employer at the address provided in the Bidding Data;
 - (b) Bear the name and identification number of the contract as defined in the Bidding Data; and
 - (c) Provide a warning not to open before the time and date for bid opening, as specified in the Bidding Data.
- 19.3 In addition to the identification required in Sub- Clause 19.2 hereof, the inner envelope shall indicate the name and address of the bidder to enable the bid to be returned unopened in case it is declared "late" pursuant to Clause IB.21
- 19.4 If the outer envelope is not sealed and marked as above, the Procuring Entity will assume no responsibility for the misplacement or premature opening of the Bid.

IB.20 Deadline for Submission of Bids

- 20.1 (a) Bids must be received by the Procuring Entity at the address specified no later than the time and date stipulated in the Bidding Data. In the event of the specified date for the submission of bids declared a holiday, the Bids will be received up to the appointed time on the next working day. Complete Bids must be received by the Procuring Entity at the address specified no later than the time and date stipulated in the Bidding Data. In the event of the specified date for the submission of bids declared a holiday for the Procuring Entity, the Bids will be received up to the appointed time on the next working day
- (b) Bids with charges payable will not be accepted, nor will arrangements be undertaken to collect the bids from any delivery point other than that specified above. Bidders shall bear all expenses incurred in the preparation and delivery of bids. No claims will be entertained for refund of such expenses.
- (c) Where delivery of a bid is by mail and the bidder wishes to receive an acknowledgment of receipt of such bid, he shall make a request for such

acknowledgment in a separate letter attached to but not included in the sealed bid package.

- (d) Upon request, acknowledgment of receipt of bids will be provided to those making delivery in person or by messenger.

20.2 The Procuring Entity may, at his discretion, extend the deadline for submission of bids by issuing an amendment in accordance with Clause IB.9, in which case all rights and obligations of the Procuring Entity / Employer and the bidders previously subject to the original deadline will thereafter be subject to the deadline as extended.

IB.21 Late Bids

21.1 (a) Any bid received by the Procuring Entity after the deadline for submission of bids prescribed in Clause IB.20 will be returned unopened to such bidder.

- (b) Delays in the mail, delays of person in transit, or delivery of a bid to the wrong office shall not be accepted as an excuse for failure to deliver a bid at the proper place and time. It shall be the bidder's responsibility to determine the manner in which timely delivery of his bid will be accomplished either in person, by messenger or by mail.

IB.22 Modification, Substitution and Withdrawal of Bids

22.1 Any bidder may modify, substitute or withdraw his bid after bid submission provided that the modification, substitution or written notice of withdrawal is received by the Procuring Entity / Employer prior to the deadline or the extended deadline pursuant to clause IB.20.2, for submission of bids.

22.2 The modification, substitution or notice for withdrawal of any bid shall be prepared, sealed, marked and delivered in accordance with the provisions of Clause IB.19 with the outer and inner envelopes additionally marked "MODIFICATION", "SUBSTITUTION" or "WITHDRAWAL" as appropriate.

22.3 No bid may be modified by a bidder after the deadline for submission of bids except in accordance with Sub-Clauses 22.1 and 27.2.

22.4 Withdrawal of a bid during the interval between the deadline for submission of bids and the expiration of the period of bid validity specified in the Form of Bid may result

in forfeiture of the Bid Security in pursuance to Clause IB.15.

E. BID OPENING AND EVALUATION

IB.23 Bid Opening

23.1 The Procuring Entity will open all the bids, including withdrawals, substitution and modifications made pursuant to Clause IB.22, in the presence of bidders' or their representatives who choose to attend, at the time, date and location stipulated in the Bidding Data. In the event of the specified date for the opening of bids being declared a holiday, the bids will be opened at the appointed time and location on the next working day. The bidders' representatives who are present shall sign a register evidencing their attendance.

In addition to the clause IB.23, the following procedures shall be adopted for opening competitive bidding:

- a) Single stage – two envelope bidding,
 - (i) Each bid shall comprise a single package containing two separate envelopes. Each envelope shall contain separately the technical proposal and the financial proposal;
 - (ii) The envelopes shall be marked as technical proposal and financial proposal in bold and legible letters to avoid confusion;

The envelope marked as technical proposal shall contain:

- b) The experience and past performance in the execution of similar contracts;
- c) The capabilities with respect to personnel and construction equipment
- d) The financial status and capacity; and
- e) Any other information asked for by the procuring entity in the notice inviting tenders;

Information asked for in a, b, c, d & e shall be on format explained in **IB. 37**

- (i) The second envelope marked as financial proposal shall contain the price quoted by the bidders and be retained in the custody of the procuring entity without being opened;
- (ii) The procuring entity would evaluate the technical proposal on the basis of criteria specified in the tender documents/ the

criteria upon which the bidders were pre-qualified for this specific assignment, without reference to the price and reject any proposal which does not conform to the specified requirements/ criterion. During the technical evaluation, no amendment in the technical proposal would be permitted. A list of technically qualified bidders shall be finalized in this manner;

(iii) After the evaluation and approval of the technical proposals the procuring entity, would at a time within the bid validity period, publicly open the financial proposals of the technically accepted bids only. The financial proposals found technically non-responsive shall be returned un-opened to the respective bidders; and

(iv) The bid found to be the lowest evaluated bid would be accepted;

23.2 Envelopes marked “MODIFICATION”, “SUBSTITUTION” or “WITHDRAWAL” shall be opened and read out first. Bids for which an acceptable notice of withdrawal has been submitted pursuant to Clause IB.22 shall not be opened.

23.3 The bidder’s name, total Bid Price and price of any Alternate Proposal(s), any discounts, bid modifications, substitution and withdrawals, the presence or absence of Bid Security, and such other details as the Procuring Entity may consider appropriate, will be announced by the Procuring Entity / Employer at the opening of bids.

23.4 The Procuring Entity shall prepare minutes of the bid opening including the information disclosed to those present in accordance with the Sub-Clause 23.3.

IB.24 Process to be Confidential

21.1 Information relating to the examination, clarification, evaluation, and comparison of bid and recommendations for the award of a contract shall not be disclosed to bidders or any other person not officially concerned with such process before the announcement of the final result of the bid evaluation, which shall be done at least ten (10) days prior to the award of Contract, and place the same on its and Authority’s Website (under Rule 45 of the KP Public Procurement Rules, 2014). The

announcement to all Bidders will include table(s) comprising read out prices, discounted prices, price adjustments made, final evaluated prices and recommendations against all the bids evaluated. Any effort by a bidder to influence the Procuring Entity's processing of bids or award decisions may result in the rejection of such bidder's bid. Whereas any bidder feeling aggrieved may follow Section 35 of the KPPRA Act, 2012, read with the Khyber Pakhtunkhwa Public Procurement Grievance Redressal Rules, 2017

IB.25 Clarification of Bids

- 25.1 To assist in the examination, evaluation and comparison of bids, the Procuring Entity / Employer may, at his discretion, ask any bidder for clarification of his bid, including breakdowns of unit rates. The request for clarification and the response shall be in writing but no change in the price or substance of the bid shall be sought, offered or permitted except as required to confirm the correction of arithmetic errors discovered by the Procuring Entity / Employer in the evaluation of the bids in accordance with Clause IB.28.

IB.26 Examination of Bids and Determination of Responsiveness

- 26.1 Prior to the detailed evaluation of bids, the Procuring Entity / Employer will determine whether each bid is substantially responsive to the requirements of the Bidding Documents.
- 26.2 A substantially responsive bid is one which (i) meets the eligibility criteria; (ii) has been properly signed; (iii) is accompanied by the required Bid Security; and (iv) conforms to all the terms, conditions and specifications of the Bidding Documents, without material deviation or reservation. A material deviation or reservation is one (i) which affect in any substantial way the scope, quality or performance of the Works; (ii) which limits in any substantial way, inconsistent with the Bidding Documents, the Procuring Entity / Employer's rights or the bidder's obligations under the Contract; or (iii) adoption whereof would affect unfairly the competitive position of other bidders presenting substantially responsive bids.
- 26.3 If a bid is not substantially responsive, it will be rejected by the Procuring Entity / Employer, and may not subsequently be made responsive by correction or

withdrawal of the non-conforming deviation or reservation.

IB.27 Correction of Errors

27.1 Bids determined to be substantially responsive will be checked by the Procuring Entity / Employer for any arithmetic errors. Errors will be corrected by the Procuring Entity / Employer as follows:

- (a) Where there is a discrepancy between the amounts in figures and in words, the amount in words will govern; and
- (b) Where there is a discrepancy between the unit rate and the line item total resulting from multiplying the unit rate by the quantity, the unit rate as quoted will govern, unless in the opinion of the Procuring Entity / Employer there is an obviously gross misplacement of the decimal point in the unit rate, in which case the line item total as quoted will govern and the unit rate will be corrected.

27.2 The amount stated in the Form of Bid will be adjusted by the Procuring Entity / Employer in accordance with the above procedure for the correction of errors and with the concurrence of the bidder, shall be considered as binding upon the bidder. If the bidder does not accept the corrected Bid Price, his Bid will be rejected, and the Bid Security shall be forfeited in accordance with Sub- Clause 15.6(b) hereof.

IB.28 Evaluation and Comparison of Bids

28.1 The Procuring Entity will evaluate and compare only the Bids determined to be substantially responsive in accordance with Clause IB.26.

28.2 In evaluating the Bids, the Procuring Entity / Employer will determine for each Bid the evaluated Bid Price by adjusting the Bid Price as follows:

- (a) Making any correction for errors pursuant to Clause IB.27;
- (b) Excluding Provisional Sums and the provision, if any, for contingencies in the Summary Bill of Quantities, but including competitively priced Day work; and
- (c) Making an appropriate adjustment for any other acceptable variation or deviation, including discounts or other price modification in the bids

28.3 The estimated effect of the price adjustment provisions of the Conditions of

Contract, applied over the period of execution of the Contract, shall not be taken into account in Bid evaluation.

- 28.4 If the Bid of the successful bidder is seriously unbalanced in relation to the Procuring Entity / Employer's estimate of the cost of work to be performed under the Contract, the Procuring Entity / Employer may require the bidder to produce detailed price analyses for any or all items of the Bill of Quantities to demonstrate the internal consistency of those prices with the construction methods and schedule proposed. After evaluation of the price analyses, the Procuring Entity / Employer may require that the amount of the Performance Security set forth in Clause IB.32 be increased at the expense of the successful bidder to a level sufficient to protect the Procuring Entity / Employer against financial loss in the event of default of the successful bidder under the Contract.

F. AWARD OF CONTRACT

IB.29 Award

- 29.1 Subject to Clauses IB.30 and IB.34, the Procuring Entity / Employer will award the Contract to the bidder whose bid has been determined to be substantially responsive to the Bidding Documents and who has offered the lowest evaluated Bid Price, provided that such bidder has been determined to be eligible in accordance with the provisions of Clause IB.3 and qualify pursuant to Sub-Clause IB 29.2

- 29.2 The Procuring Entity / Employer, at any stage of the bid evaluation, having credible reasons for or *prima facie* evidence of any defect in supplier's or contractor's capacities, may require the suppliers or contractors to provide information concerning their professional, technical, financial, legal or managerial competence whether already pre-qualified or not:

Provided that such qualification shall only be laid down after recording reasons therefore in writing. They shall form part of the records of that bid evaluation report.

IB.30 Procuring Entity / Employer's Right to Accept or Reject any or all Bids

- 30.1 Notwithstanding Clause IB.29, the Procuring Entity / Employer reserves the right to accept or reject any Bid, and to annul the bidding process and reject all bids, at any time prior to award of Contract, without thereby incurring any liability to the affected

bidders or any obligation except that the grounds for rejection of all bids shall upon request be communicated to any bidder who submitted a bid, without justification of grounds. Rejection of all bids shall be notified to all bidders promptly.

IB.31 Notification of Award

- 31.1 Prior to expiration of the period of bid validity prescribed by the Procuring Entity / Employer, the Procuring Entity / Employer will notify the successful bidder in writing (“Letter of Acceptance”) that his Bid has been accepted. This letter shall name the sum which the Procuring Entity / Employer will pay the Contractor in consideration of the execution and completion of the Works by the Contractor as prescribed by the Contract (hereinafter and in the Conditions of Contract called the “Contract Price”).
- 31.2 No Negotiation with the bidder having evaluated as lowest responsive or any other bidder shall be permitted, however, Procuring Entity / Employer may have clarification meetings to get clarify any item in the bid evaluation report.
- 31.3 The notification of award and its acceptance by the bidder will constitute the formation of the Contract, binding the Procuring Entity / Employer and the bidder till signing of the formal Contract Agreement.
- 31.3 Upon furnishing by the successful bidder of a Performance Security, the Procuring Entity / Employer will promptly notify the other bidders that their Bids have been unsuccessful and return their bid securities.

IB.32 Performance Security

- 32.1 The successful bidder shall furnish to the Procuring Entity a Performance Security in the form and the amount stipulated in the Bidding Data and the Conditions of Contract plus additional security for unbalanced bids in accordance with Clause IB.28.4 within a period of 28 days after the receipt of Letter of Acceptance.
- 32.2 Failure of the successful bidder to comply with the requirements of Sub-Clause IB.32.1 or Clauses IB.33 or IB.35 shall constitute sufficient grounds for the annulment of the award and forfeiture of the Bid Security.

IB.33 Signing of Contract Agreement

- 33.1 Within 14 days from the date of furnishing of acceptable Performance Security

under the Conditions of Contract, the Procuring Entity / Employer will send the successful bidder the Contract Agreement in the form provided in the Bidding Documents, incorporating all agreements between the parties.

33.2 The formal Agreement between the Procuring Entity / Employer and the successful bidder shall be executed within 14 days of the receipt of the Contract Agreement by the successful bidder from the Procuring Entity / Employer.

IB.34 General Performance of the Bidders

The Procuring Entity reserves the right to obtain information regarding performance of the bidders on their previously awarded contracts/works. The Procuring Entity / Employer may in case of consistent poor performance of any Bidder as reported by the Procuring Entity / Employers of the previously awarded contracts, inter alia, reject his bid and/or refer the case to the Pakistan Engineering Council (PEC) and KPPRA. Upon such reference, PEC/KPPRA in accordance with its rules, procedures and relevant laws of the land take such action as may be deemed appropriate under the circumstances of the case including black listing of such Bidder and debarring him from participation in future bidding for similar works.

IB.35 Integrity Pact

The Bidder shall sign and stamp the Integrity Pact provided at Appendix-L to Bid in the Bidding Documents for all Federal Government procurement contracts exceeding Rupees ten million. Failure to provide such Integrity Pact shall make the bidder non-responsive.

IB.36 Instructions not Part of Contract

Bids shall be prepared and submitted in accordance with these Instructions which are provided to assist bidders in preparing their bids, and do not constitute part of the Bid or the Contract Documents.

IB.37 Guidelines for submission of Technical Proposals

As per provision contained under KPPRA Rules, 2014, the Tender for the work is on Single Stage Two Envelopes procedure, therefore, while submitting the Technical Proposals by the Bidder(s), the detail information mentioned in the Criteria explained below are required to be followed strictly. Passing marks are as per prequalification criteria already issued.

The Bidders who do not qualify technically, his financial Bid will be returned un-opened irrespective of his pre-qualification Status. In addition, each page of the technical proposal

shall be numbered, stamped & signed by the owner of the Firm. Photocopies of signs and seals will not be considered. Attachment of un-necessary documents shall be avoided and the proposals must be well staple binded.

The document such as Letter of acceptance, award of contract, work order, completion certificate etc. must be signed by concerned officer of rank not below XEN/Deputy Director with proper letter head including concerned department contact details (Phone No. Email etc).

Not fulfilling any of the above condition the Technical Proposal will not be considered.

37.1 Technical Evaluation Criteria

(A) Name of Firm/Contractor

Eligibility Criteria

PEC Registration	C-B
Relevant Category	CE01, CE04, CE09, CE10, EE11 & ME06
Enlistment Category with Works Department Khyber Pakhtunkhwa.:	PK-CB
Bid Security, Additional Security (If any) in shape of CDR	
Form H of the Firm	
Affidavit for No Blacklisting	
Affidavit for No Litigation	
NTN Number	
KPRA Number	
Name of Owner	

Note: No prospective bidder shall be eligible for further evaluation if it failed to qualify the above eligibility criteria.

1. **EXPERIENCE RECORD: (Max Marks = 35)**

- Passing marks 50% in the three sub sections 1(a), 1(b) 1(c).
 - a. **Completed Irrigation Dam Projects in last 15 Years (15 Marks)**
(5 Marks for 1, 10 Marks for 2 and 15 Marks for 3 and more)

S.No.	Name of Completed Irrigation Dam Project (Cost Rs≥ 700 Million)	Cost	Status	Marks obt.

	Total			

Note: Completed Irrigation Dam Projects shall not include raising/upgradation/improvement of an irrigation dam.

**b. Similar Nature Completed Projects in last 10 years (10 Marks)
(2.5 Marks for 1, 4 Marks for 2, 5 Marks for 3, 10 Marks for more than 3 Projects)**

S.No.	Similar Nature Projects (Cost \geq 300 Mill)	Cost	Status	Marks obt.
	Total			

Note: Similar Nature Completed Projects mean other Irrigation infrastructure projects

**c. Other Completed Civil Engineering Projects in Last 10 Years
(Each project shall be awarded 2 Marks subject to a maximum of 10 Marks).**

S.No.	Name of Other Projects (Cost \geq 300 Mill)	Cost	Status	Marks obt.
	Total			

Total Marks obtained in Experience Category (a,b,c) =

2. EQUIPMENT CAPABILITIES: (Max Marks = 20)

List of Machinery

S/No	Machinery	Quantity Required	Total Machinery		Total Marks Obtained
			Qty	Marks	
1	Concrete Batching Plant	1			
2	Concrete Pump	1			
3	Crane Mobile	2			
4	Water Tanker	4			
5	Dumper Truck	24			
6	Showel/Loader	4			
7	Drilling/Grouting Machine	2			
8	Concrete Transit Mixer	4			
9	Sheep Foot Roller	2			
10	Plain Roller	3			
11	Excavator	8			
12	Dozer (D-8 & D-10)	5			
13	Screening Plant	1			
14	Motor Grader	2			
15	Crushing Plant	1			
16	Fully equipped Laboratory	1			
	Total				

Note:

- An affidavit will be provided regarding all the machinery either rented or owned as per above table.
- Each class of machinery shall carry equal marks subject to a total of 20 marks.

3. PERSONNEL CAPABILITIES: (Max Marks = 15)

CV of each Personnel in these bidding documents shall be provided in the Technical Proposal

- a) **Engineer**-BSc Civil Engineers duly registered with PEC (7 marks for not less than 2 engineers having exp of 10 yrs in dam projects)

S.No.	Name of Engineer	Experience	Mark Obt.
	Total		

Note: Each Engineer shall carry equal marks subject to a maximum marks of 7.

- b) **Geologist**-BS Geology (3 marks for Geologist having exp of 10 yrs in dam projects)

S. No.	Name of Geologist	Experience	Marks Obtained

- c) **DAE Diploma Sub Engineers** (3.333 marks for not less than 4 DAE having exp of 5 yrs)

S.No.	Name of Engineer	Experience	Mark Obt.
	Total		

Note: Each DAE Sub Engineer shall carry equal marks.

- d) **Surveyors** (0.833 marks for not less than 1 surveyor having DAE and exp of 5 yrs)

S.No.	Name of Engineer	Experience	Mark Obt.
	Total		

Lab Technician (0.833 marks for Lab Technician having DAE and exp of 5 yrs)

S.No.	Name of Engineer	Experience	Mark Obt.
	Total		

Total Marks obtained in Personnel Category =

4. FINANCIAL SOUNDNESS: (Max Marks = 30)

- i. Letter to be addressed to Director General, Small Dam Peshawar from a schedule bank otherwise the bidder shall not be considered.

Financial Status - Bank Credit Line (15 marks for Bank credit not less than 300 Mill)

S.No.	Name of Bank	Credit (Mill)	Mark Obt.
		Total	

Financial Status - Working Capital (15 marks for working capital not less than 500 Mill)

1 st Year	2 nd Year	3 rd Year	Average	Marks Obt.
Marks Obtained				

- The working capital shall be that amount on which income tax has been paid. The prospective bidder shall submit the income tax return for the last 03 years. For this purpose, documents, other than the income tax return for the last 03 years, shall not be considered for technical evaluation.
- No litigation & No blacklisting history may be provided on separate judicial stamp paper.

Total Marks obtained in Financial Category=

Note: Overall passing marks shall be 60%.

37.2 Joint Venture (JV)

37.2.1 Joint Venture must comply with the following requirements:

a) Following are minimum qualification requirements: -

- All joint venture partners shall fulfill the minimum criteria of valid registration with PEC & KPPRA along with code of specialization and shall have valid enlistment with Works Department, Govt of Khyber Pakhtunkhwa.
- The lead partner shall meet not less than 50 percent of all qualifying criteria given in paras 37.1 and 37.4, However, qualification of 37.1 Section-1(a) is mandatory heretofore.

(iii) Each of the partners shall meet not less than 25 percent of all the qualifying criteria given in paras 37.1 and 37.4 heretofore.

(iv) The joint venture must collectively satisfy the criteria of paras 37.1, 37.2 and 37.3, for which purpose the relevant figures for each of the partners shall be added together to arrive at the JV's total capacity. Individual members must satisfy each of the requirements of paras 37.4 and 37.5 heretofore.

b) Any change in a qualified JV after qualification, shall be subject to the written approval of the Procuring Entity prior to the deadline for submission of bids. Such approval may be denied if: -

(i) Partner(s) withdraw from a JV and remaining partners do not meet the qualifying requirements;

(ii) The new partners to a JV are not qualified individually or as another JV; or

(iii) In the opinion of the Procuring Entity, it may lead to substantial reduction in competition.

c) Bid shall be signed by all members in the JV so, as to legally bind all partners, jointly and severally, and any bid shall be submitted with a copy of the JV agreement providing the joint and several liability with respect to the contract.

37.2.2 The technical qualification of a JV does not necessarily qualify any of its partners individually or as a partner in any other JV or association. In case of dissolution of a JV, each one of the constituent firms may qualify if they meet all the qualification requirements and any partner of JV has requested/shall request for the same and his qualification shall be subject to the written approval of the Procuring Entity.

37.3 Conflict of Interest

37.3.1 The bidder (including all members of a JV) must not be associated, nor have been associated in the past, with the consultant or any other entity that has prepared the design, specifications, and other bidding documents for the project, or was proposed as Engineer for the contract, over the last five years. Any such association may result in disqualification of the Bidder.

37.5 Other Factors

37.5.1 Financial Bids of only those firms/bidders/JV will be considered for opening who have been technically qualified under this procedure. A firm or a member of a JV may participate only in one bid for the contract. If a firm submits more than one bid, singly or as a JV, all bids involving that bidder will be rejected. This rule will not apply in respect of bids which include specialist sub-contractors who are used by more than one bidder.

37.5.2 The Procurement Entity reserves the right to: -

a) Amend the scope and value of any contract(s) to be bid, in which event the bidder(s) will only bid among those technically qualified bidders who meet the requirements of the contract(s) as amended. However, the Procurement Entity has to review the disqualified bids who originally do not meet the specified criteria for qualification.

b) Reject or accept any or all applications, as per para 33 (i) of KPPRA rules 2014

c) Cancel the qualification process and reject all applications/bids.

The Procurement Entity shall neither be liable for any such actions nor be under any obligation

to inform the Bidders of the grounds for rejection, however, may be debriefed if solicited.

37.5.3 Applicants will be informed in writing by fax or e-mail after finalization of the technical qualification process.

TABLE - I

S. No:	Types of Organization	Minimum requirement of Auditors	Basis of Preparation of Audit Reports	Basis of Preparation of Financial Statements
1.	Corporate entities (duly registered with Securities and Exchange Commission of Pakistan)	Licensed Chartered Accountant Firms (Minimum Partnership Firm with international affiliation) enlisted and appearing on the list of firms in ICAP directory as at the finalization of procurement.	International auditing standards as applicable in Pakistan	(i) Companies Ordinance 1984 or Companies Act 2017 (whichever is applicable). (ii) International accounting and financial reporting standards as applicable in Pakistan at the time of issuance of the reports.
2.	Partnership Firm / AOPs / Joint Ventures.	Licensed Chartered Accountant Firms (Minimum Partnership Firm) enlisted and appearing on the list of firms in ICAP directory as at the finalization of procurement.		International accounting and financial reporting standards as applicable in Pakistan at the time of issuance of the reports.
3.	Individuals / Sole Proprietorship	Licensed Cost & Management Accountant Firms enlisted and appearing on the list of firms in ICMAP directory as at the finalization of procurement for organization of net worth up-to Rs. 10 million only. In all other cases, Licensed Chartered Accountant Firms enlisted and appearing on the list of firms in ICAP directory as at the finalization of procurement.		Consistent and acceptable Accounting policies.

BIDDING DATA

BDS-1**[NOTES ON BIDDING DATA]**

This Section is intended to assist the Procuring Entity in providing the specific information in relation to corresponding clauses in Instructions to Bidders and should be prepared to suit each individual contract.

The Procuring Entity should provide in the Bidding Data information and requirements specific to the circumstances of the Procuring Entity, the processing of the Bid, the applicable rules regarding Bid Price and currency, and the Bid evaluation criteria that will apply to the Bids. In preparing this section, the following aspects should be checked:

- (a) Information that specifies and complements the provisions of section; Instruction to Bidders must be incorporated.
- (b) Amendments and/or supplements, if any, to the provisions of Instructions to Bidders, necessitated by the circumstances of each individual contract, can be introduced only in this section since Instructions to Bidders will remain unchanged.

BIDDING DATA

The following specific data for the Works to be bided shall complement, amend, or supplement the provisions in the Instructions to Bidders. Wherever there is a conflict, the provisions herein shall prevail over those in the Instructions to Bidders.

INSTRUCTIONS TO BIDDERS

CLAUSE REFERENCE

1.1 NAME AND ADDRESS OF THE PROCURING ENTITY / EMPLOYER

Director General, Directorate General Small Dams, Irrigation Department, Government of Khyber Pakhtunkhwa through Deputy Director (P&C), Small Dam Division Kohat.

1.2 NAME OF THE PROJECT & SUMMARY OF THE WORKS

Construction of Sumari Payan Dam District Kohat.

The Project designated as Sumari Payan Dam Project District Kohat consists of Dam Embankment, Spillway, Intake/outlet Structure, Irrigation System including Canal Affiliated Structures, Relocation Road, Relocation of Police Post and Construction of Inspection Hut.

The salient features of the project are as under;

SALIENT FEATURES

<u>1</u>	<u>Reservoir</u>	
1.1	Catchment Area	35.73 sq. miles
1.2	Estimated Avg. Annual Runoff	7,796.AF
1.3	Gross Storage of Reservoir	6,205 AF
1.4	Live Storage of Reservoir	5,508 AF
1.5	Dead Storage of Reservoir	697 AF
1.6	Maximum Conservation Level	1,825 ft. a.m.s.l.
1.7	Minimum Conservation Level	1,790 ft. a.m.s.l
1.8	H.F.L	1,832.50 ft. a.m.s.l
<u>2</u>	<u>Spillway</u>	
2.1	Spillway Crest	1,825 ft. a.m.s.l.
2.2	Width of Spillway	211' 7" ft.
2.3	Maximum Inflow against 1000 year return period	50,595 cusecs
2.4	Surcharge over Spillway	7.5 ft.
2.5	Maximum outflow against 1000 year return period	45026 cusecs
<u>3</u>	<u>Diversion/Irrigation Conduit</u>	
3.1	Diameter	2.5 ft.
3.2	Length	299.25 ft.
3.3	Outlet Level	1790 ft. a.m.s.l.
<u>4</u>	<u>Dam</u>	
4.1	Type	ECRD with positive cut-off wall
4.2	Crest Elevation	1838 ft. a.m.s.l.

4.3	Freeboard above PMF	7.5 ft.
4.4	Crest Width	25 ft
4.5	Slope: Upstream Face	2.5H:1V
4.6	Slope: Downstream Face	2H:1V
4.7	Maximum Height of the Dam	71 ft.
4.8	Crest Length	2066 ft
4.9	Life of Dam	57 Years
5	<u>Irrigation</u>	
5.1	Cultivable Command Area	2200 Acres
5.2	Design Discharge	12.77 cfs
5.3	Drinking Water Supply	6,566 people @15 gallons per capita per day
5.4	Length of Main Canal	19,000 ft.
	Length of Minor Canal	9,300 ft.

2.1 A) NAME OF THE BORROWER/SOURCE OF FINANCING/FUNDING AGENCY

Govt. of Khyber Pakhtunkhwa

B) TYPE OF FINANCING

Block allocation Water Sector ADP

4.1 ONE BID PER BIDDER

Out of a parent organization and / or sister organizations, only one entity shall submit a Bid. If more than one Bid is submitted by the entities belonging to same parent organization and / or being sister organizations, all such Bids shall be rejected to avoid Conflict of Interest.

7.1 CONTENTS OF BIDDING DOCUMENTS

The Bidding Documents, in addition to invitation for bids, are those stated below and should be read in conjunction with any Addenda issued in accordance with Clause IB.9.

1. Instructions to Bidders.
2. Bidding Data.
3. Letter of Technical Bid.
4. Letter of Price Bid.
5. Appendices to Bid.
6. Forms of Bid Security.
7. Form of Performance Security.
8. Forms of Contract Agreement, and Mobilization Advance Guarantee.
9. General Conditions of Contract, Part-I (GCC).
10. Particular Conditions of Contract, Part-II (PCC)
11. Technical Specifications.
12. General Specifications (Technical Specifications for Workmanship) MRS – 2025, Khyber Pakhtunkhwa.
13. Drawings

8.1 TIME LIMIT FOR CLARIFICATION

As per NIT.

10.1 BID LANGUAGE

The language shall be English and will be used for the bid and all correspondence and documents related to the bid exchanged by a bidder and the Procuring Entity.

11.1(A) FURNISH TECHNICAL PROPOSAL

The bidder to submit a technical proposal in sufficient detail to demonstrate the adequacy of the bid in meeting requirements for timely completion of the Works.

- a) Proper Numbering and Annexures
- b) Attested photocopies (in Original)
- c) Written confirmation (Power of Attorney) authorizing a person to submit the Bid.
- d) Written confirmation (Power of Attorney) authorizing the signatory of the Bid to commit the Bid on behalf of the Bidder.
- e) Letter of Technical Bid.
- f) Bid Security.
- g) Copy of Articles of Incorporation or Constitution of the Bidder as a legal entity.
- h) Valid Certificate of Registration (Constructor's License) from Pakistan Engineering Council.
- i) Income tax returns of the prospective bidders for the last three (3) years.
- j) Joint Venture Agreement or the Letter of Intent to execute the JV Agreement (if applicable).
- k) Pending litigation and No Blacklisting information.
- l) Special Stipulations (as filled by the Procuring Entity). (Appendix –A)
- m) Proposed Construction Schedule. (Appendix –E)
- n) Method of Performing the Work. (Appendix –F)
- o) Availability of Major Equipment – Related Items. (Appendix –G)
- p) Construction Camp and Housing Facilities. (Appendix –H)
- q) List of Sub-contractors (as required). (Appendix –I)
- r) Organization Chart for Supervisory Staff. (Appendix –K)
- s) Integrity Pact. (Appendix –L)
- t) Financial Competence and Access to Financial Resources. (Appendix –M)
- u) Past Performance / Experience; Qualification of Key Staff and Current Commitments / Projects in Hand. (Appendix –N)

11.1(B) THE BIDDER SHALL SUBMIT WITH ITS PRICE BID THE FOLLOWING DOCUMENTS:

- a) Letter of Price Bid.
- b) Bill of Quantities. (Appendix –D)
- c) Estimated Progress Payments. (Appendix –J)

13.1 Bidders quote entirely in Pak Rupees

Payments shall be made in Pak Rupees only and no foreign currency payment is admissible.

14.1 PERIOD OF BID VALIDITY

Validity period for the bid will be 120 days.

15.1 AMOUNT OF BID SECURITY

At the Rate of 2% of the Estimated Cost in the shape of CDR.

17.2 VENUE, TIME AND DATE OF PRE-BID MEETING

Venue: Plot#27, St. No. 12, Sector E-8, Phase-VII, Hayatabad Peshawar

Time and Date: As Per NIT.

17.4 PRESENCE AT THE PRE-BID MEETING

Absence at the pre-bid meeting will not be a cause for disqualification of a bidder, however the bidders are asked to attend the meeting where they will be guided regarding preparation of the bids in the light of Instructions to Bidders.

18.4 NUMBER OF COPIES OF THE BID TO BE COMPLETED AND RETURNED

Each bidder shall prepare by filling out the forms completely and without alterations and by converting it to the soft form, shall upload it on E-PADS

19.2 (A) PROCURING ENTITY / EMPLOYER'S ADDRESS FOR THE PURPOSE OF BID SUBMISSION

To be uploaded on E-PADS.

19.2 (B) NUMBER OF THE CONTRACT

Construction of Sumari Payan Dam District Kohat

20.1 DEADLINE FOR SUBMISSION OF BIDS:

As Per NIT.

23.1 VENUE, TIME AND DATE OF BID OPENING

As Per NIT.

32.1 STANDARD FORM AND AMOUNT OF PERFORMANCE SECURITY ACCEPTABLE TO THE PROCURING ENTITY

The Contractor shall provide Performance Security to the Procuring Entity in the prescribed form. The said Security shall be furnished or caused to be furnished by the Contractor within 28 days after the receipt of the Letter of Acceptance. The Performance Security shall be of an amount equal to 10% of the Contract Price stated in the Letter of Acceptance. Such Security shall be in the form of bank guarantee from any Scheduled Bank in Pakistan.

LETTERS OF TECHNICAL BID/PRICE BID

AND

APPENDICES TO BID

LTB-1

LETTER OF TECHNICAL BID

Date:

Bid Reference No: Construction of Sumari Payan Dam
Project District Kohat

To

**Director General,
Small Dams Peshawar**

We, the undersigned, declare that:

- (a) We have examined and have no reservations to the Bidding Documents, including Addenda issued in accordance with Instructions to Bidders (IB) 9;
- (b) We offer to execute and complete in conformity with the Bidding Documents the Work, *“Construction of Sumari Payan Dam District Kohat”*.
- (c) Our Bid consisting of the Technical Bid and the Price Bid shall be valid for a period of 120 days from the date fixed for the bid submission deadline in accordance with the Bidding Documents, and it shall remain binding upon us and may be accepted at any time before the expiry of that period;
- (d) As security for due performance of the under takings and obligations of our bid, we submit here with a Bid security, in the amount specified in Bidding Data Sheet, which is valid (at least) 28 days beyond validity of Bid itself.
- (e) We are not participating, as a Bidder or as a subcontractor, in more than one bid in this bidding process, other than alternative offers submitted in accordance with IB16 (as applicable
- (f) We agree to permit Procuring Entity or its representative to inspect our accounts and records and other documents relating to the bid submission and to have them audited by auditors. This permission is extended for verification of any information provided in our Technical Bid which comprises all documents enclosed herewith in accordance with IB.11.1 of the Bidding Data Sheet.

Name

In the capacity of

Signed

Duly authorized to sign the Bid for and on behalf of

Date

.....

.....

Address.....

LB-1

LETTER OF PRICE BID**Date:****Bid Reference No:** Construction of Sumari Payan Dam
District Kohat

To

**Director General,
Small Dams Peshawar**

We, the undersigned, declare that:

- (a) We have examined the Bidding Documents including Instructions to Bidders, Bidding Data, and Conditions of Contract. Specifications, Drawings, Bill of Quantities and Addenda for the execution of the above-named Works and have no reservations to the Bidding Documents, including Addenda issued in accordance with Instructions to Bidders (IB) 9.
- (b) We offer to execute and complete such Works and remedy any defects therein in conformity with the Conditions of Contract. Specifications, Drawings, Bill of Quantities and Addenda for the sum of Rs. _____ (Rupees _____) or such other sum as may be ascertained in accordance with the said conditions. We understand that all the Appendices attached hereto form part of this Bid.
- (c) We undertake, if our Bid is accepted, to obtain a performance security in accordance with the Bidding Documents, Commence the Works and to Complete the whole of the Works comprised in the Contract within the time stated in Appendix-A to Bid.
- (d) We agree to abide by this Bid for the period of days from the date fixed for the bid submission deadline in accordance with the Bidding Documents and it shall remain binding upon us and may be accepted at any time before the expiration of that period.

LPB-2

- (e) Unless and until a formal Agreement is prepared and executed, this Bid, together with your written acceptance thereof, shall constitute a binding contract between us.
- (f) We do hereby declare that the Bid is made without any collusion, comparison of figures or arrangement with any other bidder for the Works.
- (g) We understand that you are not bound to accept the lowest or any Bid you may receive.

Dated this _____ day of _____ 20_____

Signature: _____

in the capacity of _____ duly authorized to sign Bids for and on behalf of
of

_____ (Name of Bidder in Block Capitals) (CNIC #)

_____ (Seal)

Address: _____

Witness:

Signature: _____

Name: _____

CNIC # _____

Address. _____

Occupation _____

APPENDICES

BA-1

Appendix-A to Bid

SPECIAL STIPULATIONS**CLAUSE****CONDITIONS OF CONTRACT**

1.	Engineer's Authority to issue Variation in emergency	2.1	2% of the Contract Price as stated in the Letter of Acceptance.
2.	Amount of Performance Security	10.1	10% of Contract Price as stated in the Letter of Acceptance.
3.	Time for Furnishing Programme	14.1	Within 30 days from the date of receipt of Letter of Acceptance.
4.	Minimum amount of Third-Party Insurance	23.2	Rs. 1.0 million per occurrence with number of occurrences unlimited.
5.	Time for Commencement	41.1	Within 14 days from the date of receipt of Engineer's Notice to Commence which shall be issued within fourteen (14) days after signing of Contract Agreement.
6.	Time for Completion	43.1, 48.2	3 years from the date of receipt of Engineer's Notice to Commence.
7.	Amount of Liquidated Damages	47.1	@ 0.04 % of the Contract price for each day of delay in completion of the Works subject to a maximum of 10% of Contract Price stated in the Letter of Acceptance.
8.	Defects Liability Period	49.1	365 days from the effective date of Taking Over Certificate.
9.	Percentage of Retention Money	60.2	10% of the amount of Interim Payment Certificate.
10	Limit of Retention Money	60.2	5% of the Contract Price as stated in the Letter of Acceptance.
11	Minimum amount of Interim Payment Certificates (Running Bills)	60.2	Rs. 10,000,000. (Ten Million)
12	Time of Payment from delivery of Engineer's Interim Payment Certificate to the Procuring Entity / Employer.	60.10	28 days, subject to availability of funds, work done or any other unavoidable hindrance.
13	Mobilization Advance (Interest Free)	60.12	10% of Contract Price as stated in the Letter of Acceptance in two instalments.

BB-1
Appendix-B to Bid

FOREIGN CURRENCY REQUIREMENTS

NOT APPLICABLE

BC-1

Appendix-C to Bid

PRICE ADJUSTMENT UNDER CLAUSE 70 OF CONDITIONS OF CONTRACT

The source of indices and the weightages or coefficients for use in the adjustment formula under Clause 70 shall be as follows (Price adjustment will be worked out as per Pakistan Engineering Council Formula):

Cost Element	Description	Weightages	Applicable index
1	2	3	4
(i)	Fixed Portion	0.35	
(ii)	Local Labour (Skilled & Unskilled) <i>With unskilled as representative items.</i>	0.15	Government of Pakistan (GoP) Federal Bureau of Statistics (FBS) Monthly Statistical Bulletin.
(iii)	Cement – in bags. <i>Portland cement shall be considered representative items for all types of cement.</i>	0.15	Government of Pakistan (GoP) Federal Bureau of Statistics (FBS) Monthly Statistical Bulletin
(iv)	Reinforcing Steel - in tons. <i>½ “diameter round bar is the representative item for all types of steel to be used in this project.</i>	0.15	Government of Pakistan (GoP) Federal Bureau of Statistics (FBS) Monthly Statistical Bulletin
(v)	High Speed Diesel (HSD) – in Liter	0.20	Fixed by OGRA
Total		1.00	

Notes:

- 1) Indices for “(ii)” to “(v)” shall be taken from the Government of Pakistan Federal Bureau of Statistics, Monthly Statistical Bulletin for the nearest city of the project area. The base cost indices or prices shall be those applying 28 days prior to the latest day for submission of bids. Current indices or prices shall be those applying 28 days prior to the last day of the billing period.
- 2) Any fluctuation in the indices or prices of materials other than those given above shall not be subject to adjustment of the Contract Price.
- 3) Except Labour & POL, if any other adjustable item(s) is not used in the particular billing period, then the ratio of the current date price and the base date price for this particular adjustable item(s) shall be considered as one.
- 4) Pakistan Engineering Council price adjustment formula and guidelines will be used for escalation.
- 5) The weightages other than fixed, are provided for the guidance of the contractor and shall be subjected to adjustments, if any, on completion of the works as per procedure defined in the price adjustment documents.

BILL OF QUANTITIES**A. PREAMBLE**

1. The Bill of Quantities shall be read in conjunction with the Conditions of Contract, Specifications & Drawings and these bidding documents.
2. The quantities given in the Bill of Quantities are estimated and provisional, and are given to provide a common basis for bidding. The basis of payment will be the actual quantities of work executed and measured by the Contractor and verified by the Engineer / Engineer representative and valued at the rates and prices entered in the priced Bill of Quantities, where applicable, and otherwise at such rates and prices as the Engineer may fix as per the Contract.
3. The rates and prices, resulting from the bidders quoted **SINGLE PERCENTAGE RATE**, with two digits after the decimal point, "**ABOVE / BELOW / AT PAR**" of the Engineer's Estimated Cost on Market Rate System – 2025 and Non-Schedule Items as well , shall, except insofar as it is otherwise provided under the Contract include all costs of Contractor's plant, labour, supervision, materials, execution, insurance, profit, taxes and duties, together with all general risks, liabilities and obligations set out or implied in the Contract. Furthermore, all duties, taxes and other levies payable by the Contractor under the Contract, or for any other cause, as on the date 28 days prior to deadline for submission of Bids, shall be included in the offered percentage's "**ABOVE / BELOW / AT PAR**" of the Engineer's Estimated Rates and Prices and the Total Bid Price, by the Bidder. Any new item/items cropped up during construction will be paid as per MRS 2025 (1st Bi Annual) with application of the bidders quoted premium, if any.
4. The whole cost of complying with the provisions of the Contract shall be included in the items provided in the priced Bill of Quantities, and where no items are provided, the cost shall be deemed to be distributed among the rates and prices entered for the related items of the Works.
5. General directions and description of work and materials are not necessarily repeated nor summarized in the Bill of Quantities. References to the relevant sections of the Bidding Documents shall be made before entering prices against each item in the priced Bill of Quantities.
6. Provisional sums included and so designated in the Bill of Quantities shall be expended in whole or in part at the direction and discretion of the Engineer in accordance with Sub-Clause 58.2 of Part I, General Conditions of Contract.

BILL OF QUANTITIES

C. DAYWORK SCHEDULE

General

1. Reference is made to Sub-Clause 52.4 of the General Conditions of Contract Part-I. Work shall not be executed on a day work basis except by written order of the Engineer. Bidders shall enter basic rates for Daywork items in the Schedules, which rates shall apply to any quantity of Daywork ordered by the Engineer. Nominal quantities have been indicated against each item of Daywork, and the extended total for Daywork shall be carried forward to the Bid Price.

Daywork Labour

2. In calculating payments due to the Contractor for the execution of Daywork, the actual time of classes of labour directly doing the Daywork ordered by the Engineer and for which they are competent to perform will be measured excluding meal breaks and rest periods. The time of gangers (charge hands) actually doing work with the gang will also be measured but not the time of foreman or other supervisory personnel.
3. The Contractor shall be entitled to payment in respect of the total time that labour is employed on Daywork, calculated at the basic rates entered by him in the Schedule of Daywork Rates for labour together with an additional percentage, payment on basic rates representing the Contractor's profit, overheads, etc., as described below:
 - a) the basic rates for labour shall cover all direct costs to the Contractor, including (but not limited to) the amount of wages paid to such labour, transportation time, overtime, subsistence allowances and any sums paid to or on behalf of such labour for social benefits in accordance with Pakistan law. The basic rates will be payable in local currency only; and
 - b) the additional percentage payment to be quoted by the Bidder and applied to costs incurred under (a) above shall be deemed to cover the Contractor's profit, overheads, superintendence, liabilities and insurances and allowances to labour timekeeping and clerical and office work; the use of consumable stores, water, lighting and power; the use and repair of stagings, scaffolding, workshops and stores, portable power tools, manual plant and tools; supervision by the Contractor's staff, foremen and other supervisory personnel; and charges incidental to the foregoing.

BD-2
Appendix-D to Bid

SCHEDULE OF DAYWORK RATES

I. Labour

Item #	Description	Unit	Quantity	Rate (Rs)	Amount (Rs)
1	Ganger	Hour	75		
2	Labour	Hour	175		
3	Brick Layer	Hour	75		
4	Mason	Hour	90		
5	Carpenter	Hour	100		
6	Steel work Erector	Hour	125		
7	Steel work binders	Hour	125		
8	Driver for vehicles up to 10 tons	Hour	150		
9	Operator for Excavator, shovel or crane.	Hour	150		
10	Operator for tractor, dozer blade or ripper.	Hour	150		
11	Operator for compressor machine	Hour	100		
12	Other Skilled operators	Hour	100		

Sub Total: (without Contractor's profit)	
Allow _____% of subtotal for Contractor's overhead , profit etc., (in accordance with Paragraph 3(b) of Daywork Schedule)	
Total for Daywork – Labor:	

BD-3
Appendix-D to Bid**Daywork Material**

4. The Contractor shall be entitled to payment in respect of materials used for Daywork (except for materials for which the cost is included in the percentage addition to labour costs as detailed heretofore), at the basic rates entered by him in the Schedule of Daywork Rates for materials together with an additional percentage payment on the basic rates to cover overhead charges and profit, as follows:
- a) the basic rates for materials shall be calculated on the basis of the invoiced price, freight, insurance, handling expenses, damage, losses, etc., and shall provide for delivery to store for stockpiling at the site. The basic rates shall be stated in local currency but payment will be made in the currency or currencies expended upon presentation of supporting documentation;
 - b) the additional percentage payment shall be quoted by the Bidder and applied to the equivalent local currency payments made under Sub-Para(a) above; and
 - c) the cost of hauling materials used on work ordered to be carried out as Daywork from the store or stockpile on the site to the place where it is to be used will be paid in accordance with the terms for Labour and Constructional Plant in this Schedule.

BD-4

Appendix-D to Bid

SCHEDULE OF DAYWORK RATES**II. Materials**

Item #	Description	Unit	Quantity	Rate (Rs)	Amount (Rs)
1	Ordinary Portland cement.	bags	1,500		
2	Sulphate resistant cement in bags.	bags	700		
3	Reinforcing Steel up to 25mm diameter to BS 4449 or equivalent.	Metric.Ton	15.000		
4	Structural Steel WF 200mm x 150mm x 12mm.	Metric.Ton	7		
5	Aggregates for Concrete.	cu.m	200		
6	Sand for Concrete.	cu.m	150		
Sub Total: (without Contractor's profit)					
Allow _____% of subtotal for Contractor's overhead, profit etc., (in accordance with Paragraph 4(b) of Daywork Schedule)					
Total for Daywork – Materials:					

BD-5
Appendix-D to Bid**Daywork Constructional Plant**

5. The Contractor shall be entitled to payments in respect of constructional plant already on Site and employed on Daywork at the basic rental rates entered by him in the Schedule of Daywork Rates for constructional plant. The said rates shall be deemed to include complete allowance for depreciation, interest, indemnity and insurance, repairs, maintenance, supplies, fuel, lubricants, and other consumables, and all overhead, profit and administrative costs related to the use of such equipment. The cost of drivers, operators and assistants will be paid for separately as described under the section on Daywork Labour.
6. In calculating the payment due to the Contractor for constructional plant employed on Daywork, only the actual number of working hours will be eligible for payment, except that where applicable and agreed with the Engineer, the travelling time from the part of the Site where the constructional plant was located when ordered by the Engineer to be employed on Daywork and the time for return journey thereto shall be included for payment.
7. The basic rental rates for constructional plant employed on Daywork shall be stated in Pakistani Rupees.

BD-6

Appendix-D to Bid

SCHEDULE OF DAYWORK RATES**III. Constructional Plant**

Item #	Description	Unit	Quantity	Rate (Rs)	Amount (Rs)
1	Excavator (Hydraulic), face-shovel or dragline:				
	1: up to including 1 Cu. M.	Hour	60		
	2: over 1 to 2 Cu.M.	Hour	60		
	3: over 2 Cu. M.	Hour	55		
2	Tractor (tracked) including bull or angle dozer:				
	1: up to and including 150 HP	Hour	50		
	2: over 150 to 200 HP	Hour	60		
	3: over 200 to 250HP	Hour	50		
3	Tractor (tracked) with ripper				
	1: over 150 to 200 HP	Hour	60		
	2: over 200 to 250HP	Hour	60		
4	Wheel Loader up to 4 Cu.m capacity	Hour	60		
5	Rear Dump Trucks				
	1: 10 tons capacity	Hour	60		
	2: 20 tons capacity	Hour	65		
7	Concrete Mixer up to 1 Cu.M.	Hour	60		
<p>Total for Daywork – Constructional Plant <i>(Including Contractor's overhead, profit etc., in accordance with Paragraph 5 of Daywork Schedule)</i></p>					

BD-7

Appendix-D to Bid

DAYWORK**Summary (Daywork)**

		Amount (Rs.)
(I)	Sub Total for Daywork: Labour	_____
(II)	Sub Total for Daywork : Materials	_____
(III)	Sub Total for Daywork: Constructional Plant	_____
Total for Daywork		_____
(Carried forward to Summary Page of Bill of Quantities at BD-2)		

BE-1

Appendix-E to Bid

PROPOSED CONSTRUCTION SCHEDULE

Pursuant to Sub-Clause 43.1 of the General Conditions of Contract, the Works shall be completed on or before the date stated in Appendix-A to Bid. The Bidder shall provide as Appendix-E to Bid, the Construction Schedule as specified herein showing the sequence of work items and the period of time during which he proposes to complete each work item in such a manner that his proposed programme for completion of the whole of the Works (and parts of the Works) may meet Procuring Entity completion targets in days noted below and counted from the date of receipt of Engineer's Notice to Commence.

The bidders are required to submit the Summary of Proposed Construction Schedule as specified in Bidding Data Sheet. However, the other details of schedule mentioned in sub-paragraphs (a), (b) & (c) below, will be submitted by the successful bidder to the Procuring Entity after the Contract Agreement is signed and letter of Commencement is issued.

- a) Manpower, Equipment, and other resources must be allocated to each activity according to their capacity.
- b) Critical Path be identified in different colour.
- c) CD containing the soft copy of schedule in Primavera format (P6) must be provided, in which the linkage between manpower, equipment and activities must be provided.

(Attach sheets as required for the specified form of Construction Schedule):

Description	Time for Completion
a) Embankment	_____days
b) Spillway Structure & Spillway Channel	_____days
c) Intake / Outlet Structure	_____days
d) Irrigation System and Canal Affiliated Structures	_____days
e) Access Road	_____days
f) Electrification of Dam & Access Road	_____days
g) Rest House	_____days

BF-1

Appendix-F to Bid

METHOD OF PERFORMING THE WORK

[The Bidder is required to submit a narrative outlining the method of performing the Work. The narrative should indicate in detail and include but not be limited to:

1. Organization Chart indicating head office and field office personnel involved in management and supervision, engineering, equipment maintenance and purchasing.
2. Mobilization at Site, the type of facilities including personnel accommodation, office accommodation, provision for maintenance and for storage, communications, security and other services to be used.
3. The method of executing the Works, the procedures for installation of equipment and machinery and transportation of equipment and materials to the site.
4. Methodology Regarding Safety of Environment/ Environmental Management Plan (EMP), as per EPA rules.
5. Quality control / Quality assurance measures to be adopted including procedures to be followed for carrying out all tests required under specifications.
6. Safety/ Security Management System

BG-1**Appendix-G to Bid****LIST OF MAJOR EQUIPMENT – RELATED ITEMS**

[The Bidder will provide on Sheet 2 of this Appendix a list of all major equipment and related items, under separate heading for items owned, to be purchased or to be arranged on lease by him to carry out the Works. The information shall include make, type, capacity, and anticipated period of utilization for all equipment which shall be in sufficient detail to demonstrate fully that the equipment will meet all requirements of the Specifications.]

BG-2

Appendix-G to Bid

LIST OF MAJOR EQUIPMENT

Owned Purchased or Leased	Description of Unit (Make, Model, Year)	Capacity HP Rating	Condition	Present Location or Source	Date of Delivery at Site	Period of Work on Project
1	2	3	4	5	6	7
a. Owned						
b. To be Purchased						
c. To be arranged on Lease						

BH-1

Appendix-H to Bid

CONSTRUCTION CAMP AND HOUSING FACILITIES

The Contractor in accordance with Clause 34 of the Conditions of Contract shall provide description of his construction camp's facilities and staff housing requirements.

The Contractor shall be responsible for pumps, electrical power, water and electrical distribution systems, and sewerage system including all fittings, pipes and other items necessary for servicing the Contractor's construction camp.

The Bidder shall list or explain his plans for providing these facilities for the service of the Contract as follows:

1. Site Preparation (clearing, land preparation, etc.).
2. Provision of Services.
 - a) Power (expected power load, etc.).
 - b) Water (required amount and system proposed).
 - c) Sanitation (sewage disposal system, etc.).
3. Construction of Facilities
 - a) Contractor's Office. Workshop and Work Areas (areas required and proposed layout, type of construction of buildings, etc.).
 - b) Warehouses and Storage Areas (area required, type of construction and layout).
 - c) Housing and Staff Facilities (Plans for housing for proposed staff, layout, type of construction, etc.).
4. Construction Equipment Assembly and Preparation (detailed plans for carrying out this activity).
5. Other Items Proposed (Security services, etc.).
6. Detail of testing Lab with testing equipment etc.

BI-1

Appendix-I to Bid

LIST OF SUBCONTRACTORS

I/We intend to subcontract the following parts of the Work to subcontractors. In my/our opinion, the subcontractors named hereunder are reliable and competent to perform that part of the work for which each is listed.

Enclosed are documentation outlining experience of subcontractors, the curriculum vitae and experience of their key personnel who will be assigned to the Contract, equipment to be supplied by them, size, location and type of contracts carried out in the past.

Part of Works (Give Details)	Subcontractor (With Complete Address)
1	2

BJ-1

Appendix-J to Bid

ESTIMATED PROGRESS PAYMENTS

Bidder's estimate of the value of work which would be executed by him during each of the periods stated below, based on his Programme of the Works and the Rates in the Bill of Quantities:

Quarter/ Year/ Period	Amounts (Rs.)
1 st Quarter	
2 nd Quarter	
3 rd Quarter	
4 th Quarter	
5 th Quarter	
6 th Quarter	
7 th Quarter	
8 th Quarter	
Bid Price	

BK-1

Appendix-K to Bid

ORGANIZATION CHART

FOR THE

SUPERVISORY STAFF AND LABOUR

*(It shall be restricted to the staff and labor to be allocated to the Contract in case of award; brochure of the Firm listing the entire staff of the Firm **should not** be attached).*

BL-1

Appendix-L to Bid

(INTEGRITY PACT)

**DECLARATION OF FEES, COMMISSION AND BROKERAGE ETC.
PAYABLE BY THE SUPPLIERS OF GOODS, SERVICES & WORKS IN
CONTRACTS WORTH RS. 10.00 MILLION OR MORE**

Contract No. _____ Dated _____

Contract Value: _____

Contract Title: Construction of Sumari Payan Dam District Kohat.

..... [Name of Constructor] hereby declares that it has not obtained or induced the procurement of any contract, right, interest, privilege or other obligation or benefit from Government of Pakistan/Khyber Pakhtunkhwa (GoP/GoKP) or any administrative subdivision or agency thereof or any other entity owned or controlled by GoP through any corrupt business practice.

Without limiting the generality of the foregoing, [name of Constructor] represents and warrants that it has fully declared the brokerage, commission, fees etc. paid or payable to anyone and not given or agreed to give and shall not give or agree to give to anyone within or outside Pakistan either directly or indirectly through any natural or juridical person, including its affiliate, agent, associate, broker, consultant, director, promoter, shareholder, sponsor or subsidiary, any commission, gratification, bribe, finder's fee or kickback, whether described as consultation fee or otherwise, with the object of obtaining or inducing the procurement of a contract, right, interest, privilege or other obligation or benefit in whatsoever form from GoP/GoKP, except that which has been expressly declared pursuant hereto.

..... [Name of Constructor] certifies that it has made and will make full disclosure of all agreements and arrangements with all persons in respect of or related to the transaction with GoP/GoKP and has not taken any action or will not take any action to circumvent the above declaration, representation or warranty.

..... [Name of Constructor] accepts full responsibility and strict liability for making any false declaration, not making full disclosure, misrepresenting facts or taking any action likely to defeat the purpose of this declaration, representation and warranty. It agrees that any contract, right, interest, privilege or other obligation or benefit obtained or procured as aforesaid shall, without prejudice to any other rights and remedies available to GoP/GoKP under any law, contract or other instrument, be voidable at the option of GoP/GoKP.

Notwithstanding any rights and remedies exercised by GoP/GoKP in this regard, [name of Constructor] agrees to indemnify GoP/GoKP for any loss or damage incurred by it on account of its corrupt business practices and further pay compensation to GoP/GoKP in an amount equivalent to ten times the sum of any commission, gratification, bribe, finder's fee or kickback given by [name of Supplier] as aforesaid for the purpose of obtaining or inducing the procurement of any contract, right, interest, privilege or other obligation or benefit in whatsoever form from GoP/GoKP.

Name of Procuring Entity:

Name of Constructor:

Signature:

[Seal]

Signature:

[Seal]

BM-1
Appendix-M to Bid

FINANCIAL COMPETENCE AND ACCESS TO FINANCIAL RESOURCES

The financial position of the bidder shall be checked as per the following details:

1) **SOUNDNESS AND ACCESS TO FINANCIAL RESOURCES (CASH FLOW)**

The Bidder must demonstrate access to, or availability of, financial resources such as liquid assets, unencumbered real assets, lines of credits*, and other financial means, other than any contractual advance payments, to meet the financial requirements of the contract in the amount to satisfy the Cash Flow requirement. As a minimum the Bidder must show that his resources, in term of at least his latest year's working capital and line of credits, will be adequate to cover an amount equivalent to his bid price and current work commitments i.e.

(Three Years Average Working Capital + Project specific lines of credit* – 100% of current contract commitments) ≥ Bid price.

Working capital is the difference between current assets and current liabilities and measures the firm's ability to generate cash in the short term.

**Any Credit Line Facility indicated for this (tendered) project needs to have been certified by the Bank and the said certificate(s) be enclosed with this Appendix.*

2) **AVERAGE ANNUAL CONSTRUCTION TURNOVER**

Criteria	Bidders to list their certified yearly Construction Turnover for last 3 years
Minimum Average Annual Construction Turnover of Pak. Rupees..... Million calculated as total certified payments received for contracts in progress or completed, within the last 3 years.	

BN-1
Appendix-N to Bid

PAST PERFORMANCE AND EXPERIENCE

1) **GENERAL CONSTRUCTION EXPERIENCE**

Requirement	Bidder to Provide details	Role
Experience under construction contracts in the role of Contractor or Management Contractor for at least the last 15 years prior to the bid submission deadline.	Certificate of registration of Firm / PEC registration along with experience record	Contractor, or Management Contractor

2) **CONTRACTS OF SIMILAR SIZE AND NATURE**

Requirement	Bidder to provide specific details	Role
Participation as Contractor or Management Contractor, in at least 2 Contracts within the last years, each with a value of at least Pak. Rupees Million that has been successfully or is substantially completed and that are similar to the proposed works. The similarity shall be based on the physical size, complexity, methods, technology or other characteristics as indicated in these Bidding Documents. <i>(Letter of Award, BOQ & Completion Certificates duly certified by Project Authorities must to be provided).</i>	<ul style="list-style-type: none"> • Letter of acceptance. • Signed Bill of Quantities (BOQ). • Completion certificate 	Contractor or Management Contractor (but not as Sub-Contractor)

BN-2

Appendix-N to Bid

QUALIFICATION OF KEY STAFF***(List to be provided on Judicial / Stamp Paper alongwith their PEC Registration Number)***

S. No.	Name of Key Staff	Designation	CNIC No.	PEC Registration No.	Qualification	Experience
1						
2						
3						
4						
5						
6						
7						
8						
9						

Note:

- The above-mentioned staffs are the minimum required key staff for this project that must be available at construction site all the time during the currency of the Contract. In case any of these staffs abandons the project site for any reason whatsoever the Contractor must immediately arrange his equivalent replacement with prior approval of the Procuring Entity / Employer.
- The staff other than above mentioned key staff e.g., supervisors, assistants, operators and laborers etc. must also be available in accordance to the Contractors Work Program.

BN-3

Appendix-N to Bid

CURRENT COMMITMENTS/PROJECTS IN HAND

S.No	Contract Identification	Name of Procuring Entity / Employer	Total Value of Work (Rs. In Million)	% age J.V share (in case of J.V)	Total Value of Work, as per J.V share (Rs. In Million)	Date of Start	*Date of Completion	Total Value of Project Completed, as per IPC w.r.t J.V share (Rs. In Million)	Average Monthly invoicing over last one year (Rs. In Million)	Balance Work, as per J.V share (Rs. In Million)	Leftover time in months	Average monthly invoicing of current commitments, to complete the balance work in time (Rs. In Million)
A	B	C	D	E	F = (D x E)	G	H	I	J	K = F - I	L = H - Base	M = K / L

Note:

- * Latest Completion date to be mentioned.
- Base date will be the date 28 days prior to the latest date for submission of Bid.

FORMS

BID SECURITY

PERFORMANCE SECURITY

CONTRACT AGREEMENT

MOBILIZATION ADVANCE

GUARANTEE/BOND

BS-1

BID SECURITY (BANK GUARANTEE)

Security Executed on _____
(Date)

Name of Surety (Bank) with Address: _____
(Scheduled Bank in Pakistan)

Name of Principal (Bidder) with Address _____

Penal Sum of Security Rupees _____ (Rs. _____)

Bid Reference No. _____

KNOW ALL MEN BY THESE PRESENTS, that in pursuance of the terms of the Bid and at the request of the said Principal (Bidder) we, the Surety above named, are held and firmly bound unto _____.

(hereinafter called the 'Procuring Entity / Employer') in the sum stated above for the payment of which sum well and truly to be made, we bind ourselves, our heirs, executors, administrators and successors, jointly and severally, firmly by these presents.

THE CONDITION OF THIS OBLIGATION IS SUCH, that whereas the Bidder has submitted the accompanying Bid dated _____ for Bid No. _____ for _____ (Particulars of Bid) to the said Procuring Entity / Employer; and

WHEREAS, the Procuring Entity / Employer has required as a condition for considering said Bid that the Bidder furnishes a Bid Security in the above said sum from a Scheduled Bank in Pakistan or from a foreign bank duly counter-guaranteed by a Scheduled Bank in Pakistan, to the Procuring Entity / Employer, conditioned as under:

- (1) that the Bid Security shall remain in force up to and including the date 28 days after the deadline for validity of bids as stated in the Instructions to Bidders or as it may be extended by the Procuring Entity / Employer, notice of which extension(s) to the Surety is hereby waived;
- (2) that the Bid Security of unsuccessful Bidders will be returned by the Procuring Entity / Employer after expiry of its validity or upon signing of the Contract Agreement; and
- (3) that in the event of failure of the successful Bidder to execute the proposed Contract Agreement for such work and furnish the required Performance Security, the entire said sum be paid immediately to the said Procuring Entity / Employer pursuant to Clause 15.6 of the Instruction to Bidders for the successful Bidder's failure to perform.

NOW THEREFORE, if the successful Bidder shall, within the period specified therefor, on the prescribed form presented to him for signature enter into a formal Contract with the said Procuring Entity / Employer in accordance with his Bid as accepted and furnish within twenty eight (28) days of his being requested to do so, a Performance Security with good and sufficient surety, as may be required, upon the form prescribed by the said Procuring Entity / Employer for the faithful performance and proper fulfilment of the said Contract or in the event of non-withdrawal of the said Bid within the time specified for its validity then this obligation shall be void and of no effect, but otherwise to remain in full force and effect.

PROVIDED THAT the Surety shall forthwith pay the Procuring Entity / Employer the said sum upon first written demand of the Procuring Entity / Employer (without cavil or argument) and without requiring the Procuring Entity / Employer to prove or to show grounds or reasons for such demand, notice of which shall be sent by the Procuring Entity / Employer by registered post duly addressed to the Surety at its address given above.

PROVIDED ALSO THAT the Procuring Entity / Employer shall be the sole and final judge for deciding whether the Principal (Bidder) has duly performed his obligations to sign the Contract Agreement and to furnish the requisite Performance Security within the time stated above, or has defaulted in fulfilling said requirements and the Surety shall pay without objection the said sum upon demand from the Procuring Entity / Employer forthwith and without any reference to the Principal (Bidder) or any other person.

IN WITNESS WHEREOF, the above bounden Surety has executed the instrument under its seal on the date indicated above, the name and seal of the Surety being hereto affixed and these presents duly signed by its undersigned representative pursuant to authority of its governing body.

	SURETY (Bank)
WITNESS:	Signature
1.	Name
	Title
Corporate Secretary (Seal)	Corporate Guarantor (Seal)
2.	

Name, Title & Address	

PS-1

**FORM OF PERFORMANCE SECURITY
(BANK GUARANTEE)**

Guarantee No. _____

Executed on _____

Expiry date _____

[Letter by the Guarantor to the Procuring Entity / Employer]

Name of Guarantor (Bank) with address: _____

(Scheduled Bank in Pakistan)

Name of Principal (Contractor) with address: _____

Penal Sum of Security (express in words and figures) _____

Letter of Acceptance No. _____ Dated _____

KNOW ALL MEN BY THESE PRESENTS, that in pursuance of the terms of the Bidding Documents and above said Letter of Acceptance (hereinafter called the Documents) and at the request of the said Principal we, the Guarantor above named, are held and firmly bound unto the _____ (hereinafter called the Procuring Entity / Employer) in the penal sum of the amount stated above for the payment of which sum well and truly to be made to the said Procuring Entity / Employer, we bind ourselves, our heirs, executors, administrators and successors, jointly and severally, firmly by these presents.

THE CONDITION OF THIS OBLIGATION IS SUCH, that whereas the Principal has accepted the Procuring Entity / Employer's above said Letter of Acceptance for _____ (Name of Contract) for the

_____ (Name of Project).

NOW THEREFORE, if the Principal (Contractor) shall well and truly perform and fulfil all the undertakings, covenants, terms and conditions of the said Documents during the original terms of the said Documents and any extensions thereof that may be granted by the Procuring Entity / Employer, with or without notice to the Guarantor, which notice is, hereby, waived and shall also well and truly perform and fulfil all the undertakings, covenants terms and conditions of the Contract and of any and all modifications of said Documents that may hereafter be made, notice of which modifications to the Guarantor being hereby waived, then, this obligation to be void; otherwise to remain in full force and virtue till all requirements of Clause 49, Defects Liability, of Conditions of Contract are fulfilled.

Our total liability under this Guarantee is limited to the sum stated above and it is a condition of any liability attaching to us under this Guarantee that the claim for payment in writing shall be received by us within the validity period of this Guarantee, failing which we shall be discharged of our liability, if any, under this Guarantee.

We, _____ (the Guarantor), waiving all objections and defences under the Contract, do hereby irrevocably and independently guarantee to pay to the Procuring Entity /

Employer without delay upon the Procuring Entity / Employer's first written demand without cavil or arguments and without requiring the Procuring Entity / Employer to prove or to show grounds or reasons for such demand any sum or sums up to the amount stated above, against the Procuring Entity / Employer's written declaration that the Principal has refused or failed to perform the obligations under the Contract which payment will be effected by the Guarantor to Procuring Entity / Employer's designated Bank & Account Number.

PROVIDED ALSO THAT the Procuring Entity / Employer shall be the sole and final judge for deciding whether the Principal (Contractor) has duly performed his obligations under the Contract or has defaulted in fulfilling said obligations and the Guarantor shall pay without objection any sum or sums up to the amount stated above upon first written demand from the Procuring Entity / Employer forthwith and without any reference to the Principal or any other person.

IN WITNESS WHEREOF, the above-bounden Guarantor has executed this Instrument under its seal on the date indicated above, the name and corporate seal of the Guarantor being hereto affixed and these presents duly signed by its undersigned representative, pursuant to authority of its governing body.

Guarantor (Bank)

1. _____

Signature _____

Corporate Secretary (Seal)

Name _____

2. _____

Title _____

Name, Title & Address

Corporate Guarantor (Seal)

CA-1

FORM OF CONTRACT AGREEMENT

THIS CONTRACT AGREEMENT (hereinafter called the "Agreement") made on the ____ / ____ /20____ between Directorate General Small Dams (hereafter called the "Procuring Entity / Employer") of the one part and _____(hereafter called the "Contractor") of the other part.

WHEREAS the Procuring Entity / Employer is desirous that certain Works, viz _____ should be executed by the Contractor and has accepted a Bid by the Contractor for the execution and completion of such Works and the remedying of any defects therein.

NOW this Agreement witness as follows:

1. In this Agreement words and expressions shall have the same meanings as are respectively assigned to them in the Conditions of Contract hereinafter referred to.
2. The following documents after incorporating addenda, if any, except those parts relating to Instructions to Bidders shall be deemed to form and be read and construed as part of this Agreement, viz:
 - (a) The Contract Agreement;
 - (b) The Letter of Acceptance;
 - (c) The completed Form of Bid;
 - (d) Special Stipulations (Appendix-A to Bid);
 - (e) The Particular Conditions of Contract – Part II;
 - (f) The General Conditions – Part I;
 - (g) The priced Bill of Quantities (Appendix-D to Bid);
 - (h) The completed Appendices to Bid (B, C, E to N);
 - (i) The Drawings;
 - (j) The Specifications.
 - (k) _____(any other)
3. In consideration of the payments to be made by the Procuring Entity / Employer to the Contractor as hereinafter mentioned, the Contractor hereby covenants with the Procuring Entity / Employer to execute and complete the Works and remedy defects therein in conformity and in all respects with the provisions of the Contract.
4. The Procuring Entity / Employer hereby covenants to pay the Contractor, in consideration of the execution and completion of the Works as per provisions of the Contract, the Contract Price or such other sum as may become payable under the provisions of the Contract at the times and in the manner prescribed by the Contract.

IN WITNESS WHEREOF the parties hereto have caused this Agreement to be executed on the day, month and year first before written in accordance with their respective laws.

Signature of the Contactor

Signature of Procuring Entity

(Seal)

(Seal)

Signed, Sealed and Delivered in the presence of:

Witness:

Witness:

(Name, Title and Address)

(Name, Title and Address)

MG-1

MOBILIZATION ADVANCE GUARANTEE/BOND

Guarantee No. _____ Date _____

WHEREAS _____ (hereinafter called the 'Procuring Entity / Employer') has entered into a Contract for _____

(Particulars of Contract)

with _____ (hereinafter called the "Contractor").

AND WHEREAS, the Procuring Entity / Employer has agreed to advance to the Contractor, at the Contractor's request, an amount of Rupees _____ (Rs _____) which amount shall be advanced to the Contractor as per provisions of the Contract.

AND WHEREAS, the Procuring Entity / Employer has asked the Contractor to furnish Guarantee to secure the mobilization advance for the performance of his obligations under the said Contract.

AND WHEREAS,

(Scheduled Bank in Pakistan)

(hereinafter called the "Guarantor") at the request of the Contractor and in consideration of the Procuring Entity / Employer agreeing to make the above advance to the Contractor, has agreed to furnish the said Guarantee.

NOW, THEREFORE, the Guarantor hereby guarantees that the Contractor shall use the advance for the purpose of above-mentioned Contract and if he fails and commits default in fulfilment of any of his obligations for which the advance payment is made, the Guarantor shall be liable to the Procuring Entity / Employer for payment not exceeding the aforementioned amount.

Notice in writing of any default, of which the Procuring Entity / Employer shall be the sole and final judge, on the part of the Contractor, shall be given by the Procuring Entity / Employer to the Guarantor, and on such first written demand, payment shall be made by the Guarantor of all sums then due under this Guarantee without any reference to the Contractor and without any objection.

This Guarantee shall remain in force until the advance is fully adjusted against payments from the Interim Payment Certificates of the Contractor or until _____ whichever is earlier.

(Date)

The Guarantor's liability under this Guarantee shall not in any case exceed the sum of Rupees _____ (Rs _____).

This Guarantee shall remain valid up to the aforesaid date and shall be null and void after the aforesaid date or earlier if the advance made to the Contractor is fully adjusted against payments from Interim Payment Certificates of the Contractor provided that the Guarantor agrees that the aforesaid period of validity shall be deemed to be extended if on the above mentioned date the advance payment is not fully adjusted.

GUARANTOR

1. Signature _____
2. Name _____
3. Title _____

WITNESS

1. _____

Corporate Secretary (Seal)2. _____
(Name Title & Address) _____
Corporate Guarantor

[Notes on the Conditions of Contract

The Conditions of Contract comprise two parts:

(a) Part I - (b) Part General Conditions of Contract

II -

Particular Conditions of Contract

Over the years, a number of “model” General Conditions of Contract have evolved. The one used in these Standard Bidding Documents was prepared by the International Federation of Consulting Engineers (Federation International des Ingenieurs-Conseils, or FIDIC), and is commonly known as the FIDIC Conditions of Contract. (The used version is the fourth edition, 1987, reprinted in 1992 with further amendments).

The FIDIC Conditions of Contract have been prepared for an ad measurement (unit price or unit rate) type of contract, and cannot be used without major modifications for other types of contract, such as lump sum, turnkey, or target cost contracts.

The standard text of the General Conditions of Contract chosen must be retained intact to facilitate its reading and interpretation by bidders and its review by the Client. Any amendments and additions to the General Conditions, specific to the contract in hand, should be introduced in the Particular Conditions of Contract.

The use of standard conditions of contract for all civil Works will ensure comprehensiveness of coverage, better balance of rights or obligations between Procuring Entity and Contractor, general acceptability of its provisions, and savings in time and cost for bid preparation and review, leading to more economic prices.

The FIDIC Conditions of Contract are copyrighted and may not be copied, faxed, or reproduced. Without taking any responsibility of its being accurate, Pakistan Engineering Council with prior consent of FIDIC Secretariat, has reproduced herein the FIDIC General Conditions of Contract for reference purpose only which cannot be used by the users for preparing their bidding documents. The bidding document may include a purchased copy, the cost of which can be retrieved as part of the selling price of the bidding document. Alternatively, the FIDIC Conditions of Contract can be referred to in the bidding documents, and the bidders are advised to obtain copies directly from FIDIC.*

* Add the following text if the bidding documents, as issued, do not include a copy:

“Copies of the FIDIC Conditions of Contract can be obtained from:

FIDIC Secretariat

P.O. Box 86

1000 Lausanne 12

Switzerland

e-mail: fidic.pub@fidic.org – FIDIC.org/bookshop]



FEDERATION INTERNATIONALE DES INGENIEURS-CONSEILS

**CONDITIONS OF CONTRACT FOR WORKS OF CIVIL
ENGINEERING CONSTRUCTION**

**PART I GENERAL CONDITIONS
WITH FORMS OF TENDER AND AGREEMENT**

FOURTH EDITION 1987
Reprinted 1988 with editorial amendments
Reprinted in 1992 with further amendments

Copies of the FIDIC Conditions of Contract 4th Edition, 1987 reprinted in
1992 with further amendments can be obtained from:

FIDIC SECRETARIAT
P.O BOX NO. 86
1000 Lausanne 12
Switzerland

e-mail fidic.pub@fidic.org-FIDIC.org/bookshop

PART II

PARTICULAR CONDITIONS OF

CONTRACT

TABLE OF CONTENTS

PART II - PARTICULAR CONDITIONS OF CONTRACT

A.	GENERAL	2
B.	BIDDING DOCUMENTS.....	3
C.	PREPARATION OF BIDS	5
D.	SUBMISSION OF BIDS.....	11
E.	BID OPENING AND EVALUATION.....	14
F.	AWARD OF CONTRACT	18
37.1	Technical Evaluation Criteria	21
	Instructions to Bidders	30
	Clause Reference.....	30
1.2	Name of the Project & Summary of the Works	30
b)	Type of Financing	31
8.1	Time Limit for Clarification	31
10.1	Bid language.....	32
11.1(A)	FURNISH TECHNICAL PROPOSAL.....	32
11.1(b)	The Bidder shall submit with its Price Bid the following documents	32
14.1	Period of Bid validity	32
15.1	Amount of Bid Security	33
17.2	Venue, Time and date of Pre-Bid Meeting.....	33
18.4	Number of copies of the Bid to be completed and returned	33
19.2 (a)	Procuring Entity / Employer's address for the purpose of Bid Submission	33
20.1	Deadline for submission of Bids.....	33
23.1	Venue, Time and Date of Bid Opening	33
32.1	Standard form and amount of Performance Security acceptable to the PROCURING ENTITY	33
A.	Preamble.....	41
C.	Daywork Schedule.....	42
1.1	Definitions.....	79
2.1	ENGINEER'S DUTIES AND AUTHORITY	79
2.8	Replacement of the Engineer	81
4.3	New Sub-Clause is added as following	81
4.3	Approval of Sub-contractor's list.....	81
5.1	Language(s) and Law	81
5.2	Priority of Contract Documents	81
6.6	Shop Drawings	82
6.7	As-Built Drawings.....	82
10.1	Performance Security.....	82
10.4	Performance Security Binding on Variations and Changes.....	83
11.1	Inspection of Site.....	83
	Add the following paragraphs at the end of this sub-clause.....	83
14.1	Programme to be Submitted	83
14.3	Cash Flow Estimate to be Submitted	84
14.5	Detailed Programme and Monthly Progress Report.....	84
15.2	Language Ability of Contractor's Representative.....	85

15.3	Contractor's Representative	85
16.3	Language Ability of Superintending Staff of Contractor	85
16.4	Employment of Local Personnel.....	85
19.1	New Sub-para's are added as following.....	85
19.1	Safety, Security and Protection of the Environment.	85
19.3	Safety Precautions	86
19.4	Lighting Work at Night.....	86
20.4	Procuring Entity / Employer's Risks	86
21.1	Insurance of Works and Contractor's Equipment	87
	(Sub-Clause 21.1 (b)): The Constructor may insure his additional cost as reflected in the sub-clause. 87	
21.2	scope of cover	87
21.3	Responsibility for Amounts not Recovered.....	87
21.4	Exclusions	87
21.5	Responsibility to Notify Insurers.....	87
25.5	Insurance Company	87
31.3	Co-operation with other Contractors	88
34.2	Rates of Wages and Conditions of Labour	88
34.3	Employment of Persons in the Service of Others	88
34.4	Housing for Labour	88
34.5	Health and Safety	88
34.6	Epidemics	89
34.7	Supply of Water	89
34.8	Alcoholic Liquor or Drugs	89
34.9	Arms and Ammunition	89
34.10	Festivals and Religious Customs	89
34.11	Disorderly Conduct	89
34.12	Compliance by Subcontractors.....	89
35.2	Records of Safety and Health.....	89
35.3	Reporting of Accidents.....	89
36.6	Use of Pakistani Materials and Services.....	90
39.3	Engineer's Decision Final	90
41.1	Commencement of Works.....	90
51.2	Instructions for Variations.....	90
52.1	Valuation of Variations	90
53.4	Failure to Comply	90
54.3	Customs Clearance.....	91
54.5	Conditions of Hire of Contractor's Equipment.....	91
59.4	Payments to Nominated Subcontractors.....	91
59.5	Certification of Payments & Nominated Subcontractors	91
60.1	Monthly Statements.....	91
60.2	Monthly Payments.....	92
60.10	Time for Payment	92
60.11	Secured Advance on Materials.....	92
60.12	Financial Assistance to Contractor.....	93
61.1	Approval only by Defects Liability Certificate	94
63.1	Default of Contractor	95
65.2	Special Risks	95
65.4	Projectile Missile	95

67.3	Arbitration.....	95
68.1	Notice to Contractor	95
68.2	Notice to Procuring Entity / Employer and Engineer.....	95
69.1	default of Procuring Entity / Employer.....	96
70.1	Increase or Decrease of Cost.....	96
73.1	Payment of Income Tax.....	98
73.2	Customs Duty & Taxes	98
74.1	Integrity Pact.....	98
75.1	Termination of Contract for Procuring Entity / Employer's Convenience.....	99
76.1	Liability of Contractor.....	99
77.1	Joint and Several LIABILITIES	99
78.1	Details to be Confidential	99
SP-01	DESCRIPTION OF THE PROJECT	103
SP-02	PROJECT FEATURES.....	104
SP-03	Drawings.....	105
SP-04	Layout of work and surveys.....	109
SP-05	Abbreviations of Standards	109
SP-06	Standards other than those specified.....	110
SP-07	Approval of materials, Equipment and Workmanship.....	110
SP-08	INSPECTION	111
SP-09	CONSTRUCTION SCHEDULE.....	111
SP-10	CONTRACTOR'S CAMP AND SITE FACILITIES TO BE PROVIDED BY THE CONTRACTOR - CONSTRUCTION AND MAINTENANCE.....	112
SP-11	WATER FOR CONSTRUCTION AND OTHER USES	112
SP-12	WEATHER CONDITIONS	113
SP-13	ASSISTANCE FOR ENGINEER/Client.....	113
SP-14	STORAGE AND USE OF EXPLOSIVES	113
SP-15	VENTILATION AND DUST CONTROL.....	114
SP-16	PHOTOGRAPHS	114
SP-17	PROVIDES SECURITY GUARDS & MANPOWER FOR EMPLOYER & ENGINEER/ENGINEER REPRESENTATIVE OFFICES ALONG WITH SERVICE CHARGES.....	114
SP-18	DIRECTED AND REQUIRED	114
SP-19	CONTRACTOR TO COOPERATE WITH OTHERS	115
SP-20	PROGRESS REPORTS AND PHOTOGRAPHS.....	115
SP-21	SAFETY AND HEALTH	115
SP-22	RESTRICTION OF WORKMEN TO SITE.....	116
SP-23	PROTECTION CHARGES AND TRIBAL ROYALTIES	116
SP-24	MOBILIZATION ADVANCE.....	116
SP-25	COMMUNICATION TO THE ENGINEERS.....	117
SP-26	Work Done After Completion Date.....	117
SP-27	MEASUREMENT AND PAYMENT	117
SP-28	DECISION OF EMPLOYER.....	118
SP-29	ADDITIONS TO AND DELETIONS FROM CLAUSES	118
SP-30	CONSTRUCTION ITEMS	118
1.1	General.....	121
1.2	COFFER DAMS	121
1.3	MEASUREMENT AND PAYMENT	122
2.1	GENERAL	123
2.2	DRAWING PRESENTATION.....	123

2.3	CLASSIFICATION OF EXCAVATION MATERIALS	123
2.4	EXCAVATION OPEN CUT - GENERAL Excavation Methods	124
2.5	Foundation PREPARATION.....	126
2.6	PRECAUTIONARY AND REMEDIAL MEASURES.....	129
2.7	ROCK EXCAVATION.....	131
2.8	ROCK QUARRIES	132
2.9	EARTH BORROW AREAS.....	133
2.10	DISPOSITION OF MATERIALS	134
2.11	MEASUREMENT AND PAYMENT	135
3.1	Scope.....	138
3.2	DEFINITIONS.....	138
3.3	GENERAL PROVISIONS	138
3.4	MATERIALS	142
3.5	CONTACT BETWEEN ROCK AND IMPERVIOUS CUTOFF	144
3.6	PREPARATION OF DAM FOUNDATION FOR FILL GENERAL.....	144
3.7	PLACEMENT	144
3.8	SPREADING	148
3.9	MOISTURE CONTROL	149
3.10	COMPACTION.....	149
3.11	SLIDES.....	152
3.12	MISCELLANEOUS FILLS AND BACKFILLS	153
3.13	BACKFILLING OF TRENCHES	154
3.14	EMBANKMENT FOR CANALS / CHANNELS	154
3.15	TESTING	155
3.16	Measurement and Payment.....	156
4.1	GENeRAL	159
4.2	INSTALLATION OF INSTRUMENTATION	159
4.3	MEASUREMENT AND PAYMENT	160
4.4	Rain Gauge	161
5.1	SCOPE	162
5.2	SPECIFICATIONS.....	162
5.3	COMPOSITION AND QUALITY	162
5.4	CEMENT	162
5.5	AGGREGATES.....	164
5.6	CONCRETE MIX STRENGTH.....	166
5.7	MEASUREMENT OF MATERIALS.....	167
5.8	MIXING METHODS.....	167
5.9	TEST OF CONCRETE	167
5.10	TRANSPORTATION OF CONCRETE	168
5.11	PLACING.....	169
5.12	COMPACTING CONCRETE.....	170
5.13	CONCRETE FINISHES	171
5.14	PLACING TEMPERATURE.....	171
5.15	CURING OF CONCRETE.....	172
5.16	PREPARATION OF EARTH SURFACES.....	173
5.17	CASTING SECTIONS AND CONSTRUCTION JOINTS.....	174
5.18	FORM WORK	175
5.19	TOLERANCES.....	177
5.20	CONCRETE FOR SECOND STAGE AND BLOCKOUTS	178

5.21	Repair of Concrete General.....	179
5.23	FINISHES AND FINISHING	183
5.24	POLYVINYL CHLORIDE WATER STOP	184
5.25	ADMIXTURES.....	185
5.26	EXPANSION JOINTS.....	186
5.27	STEEL REINFORCEMENT	186
5.28	ANCHORS IN SPILLWAY FLOOR SLABS	187
5.29	MEASUREMENT AND PAYMENT	188
5.30	CODES AND STANDARDS	189
6.1	Scope.....	191
6.2	MATERIALS	191
6.3	mortar composition	191
6.4	MORTAR BATCHING	191
6.5	SOAKING	192
6.6	LAYING OF BRICKS	192
6.7	CURING.....	192
6.8	MEASUREMENT AND PAYMENT	192
7.1	SCOPE OF WORK.....	193
7.2	GENERAL	193
7.3	CLASSIFICATIONS	193
7.4	MATERIALS	193
7.5	MIXTURE.....	193
7.6	JOINTS.....	194
7.7	MANUFACTURE.....	194
7.8	TESTING AND INSPECTION	194
7.9	REJECTION.....	194
7.10	Repair.....	195
7.11	INSTALLATION	195
7.12	MEASUREMENT AND PAYMENT	195

PART II - PARTICULAR CONDITIONS OF CONTRACT

(Mandatory Provisions not to be Amended / Substituted except as instructed by KPPRA)

1.1 DEFINITIONS

(a) (i) The Procuring Entity / Employer is **Director General, Directorate General Small Dams, Irrigation Department Government of Khyber Pakhtunkhwa Plot No. 27, Street No. 12, Sector E-8, Phase-VII, Hayatabad Peshawar.**

(a) (iv) The Engineer is **Director (South), Directorate General Small Dams.**

Or any other competent person appointed by the Procuring Entity / Employer, and notified to the Contractor, to act in replacement of the Engineer. Provided always that except in cases of professional misconduct, the outgoing Engineers is to formulate his certifications/recommendations in relation to all outstanding matters, disputes and claims relating to the execution of the Works during his tenure.

(a)(vi) "Bidder or Tenderer" means any person or persons, company, corporation, firm or joint venture submitting a Bid or Tender.

(b)(v) The following is added at the end of the paragraph:

The word "Tender" is synonymous with "Bid" and the word "Tender Documents" with "Bidding Documents".

(b)(viii) Amend Part I to read as:

"Appendices to Tender mean Appendix A through N annexed to the Tender and forming a part thereof.

Through Part I, the term "Appendix to Tender" shall be replaced by the term "Appendices to Tender".

The following paragraph is added:

(b)(ix) "Programme" means the programme to be submitted by the Contractor in accordance with Sub-Clause 14.1 and any approved revisions thereto.

(e)(i) The text is deleted and substituted with the following:

"Contract Price" means the sum stated in the Letter of Acceptance as payable to the Contractor for the execution and completion of the Works subject to such additions thereto or deductions there from as may be made and remedying of any defects therein in accordance with the provisions of the Contract.

2.1 ENGINEER'S DUTIES AND AUTHORITY

With reference to Sub-Clause 2.1(b), the following provisions shall also apply;

The Engineer shall obtain the specific approval of the Procuring Entity / Employer before carrying out his duties in accordance with the following Clauses:

- (i) Consenting to the sub-letting of any part of the Works under Sub-Clause 4.1 “Subcontracting”.
- (ii) Certifying additional cost determined under Sub-Clause 12.2 “Not Foreseeable Physical Obstructions or Conditions”.
- (iii) Any action under Clause 10 “Performance Security” and Clauses 21, 23, 24 & 25 “Insurance” of sorts.
- (iv) Any action under Clause 40 “Suspension”.
- (v) Any action under Clause 44 “Extension of Time for Completion”.
- (vi) Any action under Clause 47 “Liquidated Damages for Delay” or Payment of Bonus for Early Completion of Works (PCC Sub-Clause 47.3).
- (vii) Issuance of “Taking Over Certificate” under Clause 48.
- (viii) Issuing a Variation Order under Clause 51, except:
 - a) in an emergency* situation, as stated here below, or
 - b) if such variation would increase the Contract Price by less than the amount stated in the Appendix-A to Bid.
- (ix) Fixing rates or prices under Clause 52.
- (x) Extra payment as a result of Contractor’s claims under Clause 53.
- (xi) Release of Retention Money to the Contractor under Sub-Clause 60.3 “Payment of Retention Money”.
- (xii) Issuance of “Final Payment Certificate” under Sub-Clause 60.8.
- (xiii) Issuance of “Defect Liability Certificate” under Sub-Clause 62.1.
- (xiv) Certifying additional payment under clause 70
- (xv) Any change in the ratios of Contract currency proportions and payments thereof under Clause 72 “Currency and Rate of Exchange”.

(Note: Procuring Entity / Employer may further vary according to need of the project)

* (If in the opinion of the Engineer an emergency occurs affecting the safety of life or of the Works or of adjoining property, the Engineer may, without relieving the Contractor of any of his duties and responsibilities under the Contract, instruct the Contractor to execute all such work or to do all such things as may, in the opinion of the Engineer, be necessary to abate or reduce the risk. The Contractor shall forthwith comply with any such instruction of the Engineer. The Engineer shall determine an addition to the Contract Price, in respect of such instruction, in accordance

with Clause 52 and shall notify the Contractor accordingly, with a copy to the Procuring Entity / Employer.)

2.2 ENGINEER'S REPRESENTATIVE

The following paragraph is added:

The Engineer's representative will be notified subsequently by the Employer on the advice of the Engineer.

The following Sub-Clauses 2.7 and 2.8 are added:

2.7 ENGINEER NOT LIABLE

Approval, reviews and inspection by the Engineer of any part of the Works does not relieve the Contractor from his sole responsibility and liability for the supply of materials, plant and equipment for construction of the Works and their parts in accordance with the Contract and neither the Engineer's authority to act nor any decision made by him in good faith as provided for under the Contract whether to exercise or not to exercise such authority shall give rise to any duty or responsibility of the Engineer to the Contractor, any Subcontractor, any of their representatives or employees or any other person performing any portion of the Works.

2.8 REPLACEMENT OF THE ENGINEER

"If the Procuring Entity / Employer intends to replace the Engineer, the Procuring Entity / Employer shall, not less than 14 days before the intended date of replacement, give notice to the Contractor, of the name, address and relevant experience of the intended replacement Engineer. The Procuring Entity / Employer shall not replace the Engineer with a person against whom the Contractor raises reasonable objection by notice to the Procuring Entity / Employer, with supporting particulars."

4.3 NEW SUB-CLAUSE IS ADDED AS FOLLOWING:

4.3 APPROVAL OF SUB-CONTRACTOR'S LIST

Where a list of Sub – Contractor's is provided under Appendix – H to Bid, the Sub – Contractor's in that list shall be subject to the prior approval of the Procuring Entity (which approval notwithstanding the provision of Sub-clause 1.5 shall be at the sole discretion of the Procuring Entity).

5.1 LANGUAGE(S) AND LAW

- (a) The Contract Documents shall be drawn up in the English language.
- (b) The Contract shall be subject to the Laws of Islamic Republic of Pakistan.

5.2 PRIORITY OF CONTRACT DOCUMENTS

The documents listed at (1) to (6) of the Sub-Clause are deleted and substituted with the following:

- (1) The Contract Agreement (if completed);

- (2) The Letter of Acceptance;
- (3) The completed Form of Bid (Letter of Technical Bid and Letter of Price Bid);
- (4) Special Stipulations (Appendix-A to Bid);
- (5) The Particular Conditions of Contract – Part II;
- (6) The General Conditions of Contract – Part I;
- (7) The priced Bill of Quantities (Appendix-D to Bid);
- (8) The completed Appendices to Bid (B, C, E to N);
- (9) Particular Specifications;
- (10) General Specifications (Technical Specifications for Workmanship) - MRS 2025 (Khyber Pakhtunkhwa)
- (11) Tender Drawings

In case of discrepancies between drawings, those of larger scale shall govern unless they are superseded by a drawing of later date regardless of scale. All Drawings and Specifications shall be interpreted in conformity with the Contract and these Conditions. Addendum, if any, shall be deemed to have been incorporated at the appropriate places in the documents forming the Contract.

The following Sub-Clauses 6.6 and 6.7 are added:

6.6 SHOP DRAWINGS

The Contractor shall submit to the Engineer for review 3 copies of all shop and erection drawings applicable to this Contract as per provision of relevant Sub-Clause of the Contract.

Review and approval by the Engineer shall not be construed as a complete check but will indicate only that the general method of construction and detailing is satisfactory and that the Engineer's review or approval shall not relieve the Contractor of any of his responsibilities under the Contract.

6.7 AS-BUILT DRAWINGS

At the completion of the Works under the Contract, the Contractor shall furnish to the Engineer 6 copies and one reproducible of all drawings amended to conform with the Works as built. The price of such Drawings shall be deemed to be included in the Contract Price.

10.1 PERFORMANCE SECURITY

The text is deleted and substituted with the following:

The Contractor shall provide Performance Security to the Procuring Entity / Employer in the prescribed form. The said Security shall be furnished or caused to be furnished by the Contractor within 28 days after the receipt of the Letter of Acceptance. The Performance Security shall be of an amount equal to 10% of the Contract Price stated in the Letter of Acceptance. Such Security shall, at the option of the bidder, be in the form of either (a) bank guarantee from any Scheduled

Bank in Pakistan.

The cost of complying with requirements of this Sub-Clause shall be borne by the Contractor.

The following Sub-Clause 10.4 is added:

10.4 PERFORMANCE SECURITY BINDING ON VARIATIONS AND CHANGES

The Performance Security shall be binding irrespective of changes in the quantities or variations in the Works or extensions in Time for Completion of the Works which are granted or agreed upon under the provisions of the Contract.

11.1 INSPECTION OF SITE

Add the following paragraphs at the end of this sub-clause:

The Contractor shall satisfy himself as to the nature of the ground, the hydrological and climatic conditions, the form and nature of the Site, the quantities and nature of the Work and materials necessary for the completion of the Works, and the means of access to the Site, the accommodation he may require and in general shall himself obtain all necessary information as to risks, contingencies, and other circumstances which may influence or affect his Bid. The Procuring Entity does not guarantee the correctness of any data/information/drawings either verbal and/or written provided herein nor any interpretations, or conclusions relative to conditions at Site. The Contractor must form his own opinion of the character of the Work and of the materials to be excavated etc. He must make his own interpretations, and satisfy himself by his own investigations and research regarding all conditions affecting the Work to be done. The Contractor must assume all responsibility for presumptions and conclusions as to the nature or conditions of the materials to be excavated and of doing other work affected by the geology at the Site.

In particular and without limiting the generality of the aforesaid, the Contractor shall not rely upon such opinion or interpretation of the Procuring Entity / Employer, for any claim with respect to additional time or cost under the contract.

14.1 PROGRAMME TO BE SUBMITTED

The Contractor shall submit two copies of the programme of Works referred to in sub-Clause 14.1 within 42 days from the date of receipt of Letter of Acceptance.

The programme shall be revised every three (3) months and should include a chart of the principal quantities of the Works forecast for execution monthly, and an updated schedule of payments expected to be made to the Contractor by the Procuring Entity.

The programme shall be computerized and drawn on the critical path method, in the form of MS Project / Primavera, identifying all items of work including the temporary Works. Progress reporting by the Contractor should be supported on a monthly basis with an up-to-date analysis of the progress including a statement on items, which are, or about to become critical to the Progress of Works, alongwith proposals on how the Contractor intends to alleviate the situation.

14.3 CASH FLOW ESTIMATE TO BE SUBMITTED

The detailed Cash Flow Estimate shall be submitted within 21 days from the date of receipt of Letter of Acceptance.

The following paragraph is added at the end of this Sub-Clause:

The Cash Flow Estimate previously submitted shall be revised each time the construction programme is revised and submitted under sub-clause 14.1

The following Sub-Clause 14.5 is added:

14.5 DETAILED PROGRAMME AND MONTHLY PROGRESS REPORT

- a) For purposes of Sub-Clause 14.1, the Contractor shall submit to the Engineer detailed programme for the following:
- (1) Execution of Works;
 - (2) Labour Employment;
 - (3) Local Material Procurement;
 - (4) Material Imports, if any; and
 - (5) Other details as required by the Engineer.
- (b) During the period of the Contract, the Contractor shall submit to the Engineer not later than the 8th day of the following month, 10 copies each of Monthly Progress Reports covering:
- (1) A Construction Schedule indicating the monthly progress in percentage;
 - (2) Description of all work carried out since the last report;
 - (3) Description of the work planned for the next 56 days sufficiently detailed to enable the Engineer to determine his programme of inspection and testing;
 - (4) Monthly summary of daily job record;
 - (5) Photographs to illustrate progress; and
 - (6) Information about problems and difficulties encountered, if any, and proposals to overcome the same.
- (c) During the period of the Contract, the Contractor shall keep a daily record of the work progress, which shall be made available to the Engineer as and when requested. The daily record shall include particulars of weather conditions, number of men working, deliveries of materials, quantity, location and assignment of Contractor's equipment.

The following Sub-Clauses 15.2 and 15.3 are added:

15.2 LANGUAGE ABILITY OF CONTRACTOR'S REPRESENTATIVE

The Contractor's authorized representative shall be fluent in the English / Urdu language. Alternately an interpreter with ability of English / Urdu language shall be provided by the Contractor on full time basis.

15.3 CONTRACTOR'S REPRESENTATIVE

The Contractor's authorized representative and his other professional engineers working at Site shall register themselves with the Pakistan Engineering Council.

The Contractor's authorized representative at Site shall be authorized to exercise adequate administrative and financial powers on behalf of the Contractor so as to achieve completion of the Works as per the Contract.

The following Sub-Clauses 16.3 and 16.4 are added:

16.3 LANGUAGE ABILITY OF SUPERINTENDING STAFF OF CONTRACTOR

A reasonable proportion of the Contractor's superintending staff shall have a working knowledge of the English / Urdu language. If the Contractor's superintending staff are not fluent in English / Urdu language, the Contractor shall make competent interpreters available during all working hours in a number deemed sufficient by the Engineer.

16.4 EMPLOYMENT OF LOCAL PERSONNEL

The Contractor is encouraged, to the extent practicable and reasonable, to employ staff and labour from sources within Pakistan particularly from project area.

19.1 NEW SUB-PARA'S ARE ADDED AS FOLLOWING:**19.1 SAFETY, SECURITY AND PROTECTION OF THE ENVIRONMENT.**

- (d) The contractor shall exercise care to protect the natural landscape and shall conduct his construction operations so as to prevent any unnecessary destruction, scarring or defacing of the natural surroundings in the vicinity of the Works, except where clearing is required for permanent works, approved temporary works and for excavation operations. All trees and native vegetation shall be preserved and shall be protected from damage which may be caused by the Contractor's construction operations and equipment. On completion of the Works, all work areas shall be smoothen and graded in a manner to conform the natural appearance of the landscape. Where unnecessary destruction, scarring damage or defacing may occur as a result of the Contractor's operations, it shall be repaired, replanted or otherwise corrected as directed by the Engineer at Contractor's expense.
- (e) Borrow areas shall be located and operated so as not to detract from the future usefulness or value of the sites. Upon completion of operations, borrow areas shall be left in a safe and slightly condition. No borrow areas shall be located too close to the populated area, to jeopardize safety and security of the inhabitants.
- (f) During the performance of the work required under the Contract, the Contractor shall carry out proper and efficient measures as often as necessary to reduce the dust nuisance, and to prevent

dust originating from his operations.

The following Sub-Clauses 19.3 and 19.4 are added:

19.3 SAFETY PRECAUTIONS

In order to provide for the safety, health and welfare of persons, and for prevention of damage of any kind, all operations for the purposes of or in connection with the Contract shall be carried out in compliance with the Safety Requirements of the Government of Pakistan with such modifications thereto as the Engineer may authorize or direct and the Contractor shall take or cause to be taken such further measures and comply with such further requirements as the Engineer may determine to be reasonably necessary for such purpose.

The Contractor shall make, maintain and submit reports to the Engineer concerning safety, health and welfare of persons and damage to property, as the Engineer may from time to time prescribe.

19.4 LIGHTING WORK AT NIGHT

In the event of work being carried out at night, the Contractor shall at his own cost, provide and maintain such good and sufficient light as will enable the work to proceed satisfactorily and without danger. The approaches to the Site and the Works where the night-work is being carried out shall be sufficiently lighted. All arrangement adopted for such lighting shall be to the satisfaction of the Engineer's Representative.

20.4 PROCURING ENTITY / EMPLOYER'S RISKS

The Procuring Entity / Employer's risks are:

Delete the text and substitute with the following:

- (a) Insofar as they directly affect the execution of the Works in Pakistan:
 - (i) war and hostilities (whether war be declared or not), invasion, act of foreign enemies,
 - (ii) rebellion, revolution, insurrection, or military or usurped power, or civil war,
 - (iii) ionizing radiations, or contamination by radioactivity from any nuclear fuel, or from any nuclear waste from the combustion of nuclear fuel, radioactive toxic explosive or other hazardous properties of any explosive nuclear assembly or nuclear component thereof,
 - (iv) pressure waves caused by aircraft or other aerial devices travelling at sonic or supersonic speeds,
 - (v) riot, commotion or disorder, unless solely restricted to the employees of the Contractor or of his Subcontractors and arising from the conduct of the Works;
- (b) Loss or damage due to the use or occupation by the Procuring Entity / Employer of any Section or part of the Permanent Works, except as may be provided for in the Contract;
- (c) Loss or damage to the extent that it is due to the design of the Works, other than any part of the design provided by the Contractor or for which the Contractor is responsible;

and

- (d) Any operation of the forces of nature (insofar as it occurs on the Site) which an experienced contractor:
 - (i) could not have reasonably foreseen, or
 - (ii) could reasonably have foreseen, but against which he could not reasonably have taken at least one of the following measures:
 - (a) prevent loss or damage to physical property from occurring by taking appropriate measures, or
 - (b) insure against.

21.1 INSURANCE OF WORKS AND CONTRACTOR'S EQUIPMENT

(Sub-Clause 21.1 (b)): The Constructor may insure his additional cost as reflected in the sub-clause.

21.2 SCOPE OF COVER

Paragraph (a) of sub – clause 21.2 is amended by deletion of the words “...from start of work at site...” And by substitution thereof by the words “...from first working day after the commencement date”

21.3 RESPONSIBILITY FOR AMOUNTS NOT RECOVERED

The text is deleted and substituted with the following:

Any amounts not insured or not recovered from the insurers shall be borne by the Contractor in accordance with his responsibilities under Clause 20.

21.4 EXCLUSIONS

The text is deleted and substituted with the following:

There shall be no obligation for the insurances in Sub-Clause 21.1 to include loss or damage caused by the risks listed under Sub-Clause 20.4 paras (a) (i) to (iv).

The following Sub-Clause 21.5 is added:

21.5 RESPONSIBILITY TO NOTIFY INSURERS

It shall be the responsibility of the Contractor to notify the insurers of any changes in nature and extent of the Works and to ensure the adequacy of the insurance coverage at all times in accordance with the provision of this Clause.

The following Sub-Clause 25.5 is added:

25.5 INSURANCE COMPANY

The Contractor shall be obliged to place all insurances relating to the Contract (including, but not limited to, the insurances referred to in Clauses 21, 23 and 24) with either National Insurance Company of Pakistan or any other insurance company operating in Pakistan and acceptable to the Procuring Entity / Employer.

Costs of such insurances shall be borne by the Contractor.

The following Sub-Clause 31.3 is added:

31.3 CO-OPERATION WITH OTHER CONTRACTORS

During the execution of the Works, the Contractor shall co-operate fully with other contractors working for the Procuring Entity / Employer at and in the vicinity of the Site and also shall provide adequate precautionary facilities not to make himself a nuisance to local residents and other contractors.

The following Sub-Clauses 34.2 to 34.12 are added:

34.2 RATES OF WAGES AND CONDITIONS OF LABOUR

The Contractor shall pay rates of wages and observe conditions of labour not less favourable than those established for the trade or industry where the work is carried out. In the absence of any rates of wages or conditions of labour so established, the Contractor shall pay rates of wages and observe conditions of labour which are not less favourable than the general level of wages and conditions observed by other Procuring Entity / Employers whose general circumstances in the trade or in industry in which the Contractor is engaged are similar.

34.3 EMPLOYMENT OF PERSONS IN THE SERVICE OF OTHERS

The Contractor shall not recruit his staff and labour from amongst the persons in the services of the Procuring Entity / Employer or the Engineer; except with the prior written consent of the Procuring Entity / Employer or the Engineer, as the case may be.

34.4 HOUSING FOR LABOUR

Save insofar as the Contract otherwise provides, the Contractor shall provide and maintain such housing accommodation and amenities as he may consider necessary for all his supervisory staff and labour, employed for the purposes of or in connection with the Contract including all fencing, electricity supply, sanitation, cookhouses, fire prevention, water supply and other requirements in connection with such housing accommodation or amenities. On completion of the Contract, these facilities shall be handed over to the Procuring Entity / Employer or if the Procuring Entity / Employer so desires, the temporary camps or housing provided by the Contractor shall be removed and the Site reinstated to its original condition, all to the approval of the Engineer.

34.5 HEALTH AND SAFETY

Due precautions shall be taken by the Contractor, and at his own cost, to ensure the safety of his staff and labour at all times throughout the period of the Contract. The Contractor shall further ensure that suitable arrangements are made for the prevention of epidemics and for all necessary welfare and hygiene requirements.

34.6 EPIDEMICS

In the event of any outbreak of illness of an epidemic nature, the Contractor shall comply with and carry out such regulations, orders and requirements as may be made by the Government, or the local medical or sanitary authorities, for purpose of dealing with and overcoming the same.

34.7 SUPPLY OF WATER

The Contractor shall, so far as is reasonably practicable, having regard to local conditions, provide on the Site, to the satisfaction of the Engineer or his representative, adequate supply of drinking and other water for the use of his staff and labour.

34.8 ALCOHOLIC LIQUOR OR DRUGS

The Contractor shall not, otherwise than in accordance with the Statutes, Ordinances and Government Regulations or Orders for the time being in force, import, sell, give, barter or otherwise dispose of any alcoholic liquor or drugs, or permit or suffer any such importation, sale, gift, barter or disposal by his Subcontractors, agents, staff or labour.

34.9 ARMS AND AMMUNITION

The Contractor shall not give, or otherwise dispose of to any person or persons, any arms or ammunition of any kind or permit or suffer the same as aforesaid.

34.10 FESTIVALS AND RELIGIOUS CUSTOMS

The Contractor shall in all dealings with his staff and labour have due regard to all recognised festivals, days of rest and religious and other customs.

34.11 DISORDERLY CONDUCT

The Contractor shall at all times take all reasonable precautions to prevent any unlawful, riotous or disorderly conduct by or amongst staff and labour and for the preservation of peace and protection of persons and property in the neighbourhood of the Works against the same.

34.12 COMPLIANCE BY SUBCONTRACTORS

The Contractor shall be responsible for compliance by his Subcontractors of the provisions of this Clause.

The following Sub-Clauses 35.2 and 35.3 are added:

35.2 RECORDS OF SAFETY AND HEALTH

The Contractor shall maintain such records and make such reports concerning safety, health and welfare of persons and damage to property as the Engineer may from time to time prescribe.

35.3 REPORTING OF ACCIDENTS

The Contractor shall report to the Engineer details of any accident as soon as possible after its occurrence. In the case of any fatality or serious accident, the Contractor shall, in addition, notify the Engineer immediately by the quickest available means.

The following Sub-Clause 36.6 is added:

36.6 USE OF PAKISTANI MATERIALS AND SERVICES

The Contractor shall, so far as may be consistent with the Contract, make the maximum use of materials, supplies, plant and equipment indigenous to or produced or fabricated in Pakistan and services, available in Pakistan provided such materials, supplies, plant, equipment and services shall be of required standard.

The following Sub-Clause 39.3 is added:

39.3 ENGINEER'S DECISION FINAL

Any decision of the Engineer under Sub – Clause 39.1 shall be final and conclusive.

41.1 COMMENCEMENT OF WORKS

The text is deleted and substituted with the following:

The Contractor shall commence the Works on Site within the period named in Appendix-A to Bid from the date of receipt by him from the Engineer of a written Notice to Commence. Thereafter, the Contractor shall proceed with the Works with due expedition and without delay.

45.1 RESTRICTION ON WORKING HOURS

After the first paragraph, add the following paragraph:

If as a result of carrying out the Works on holidays or locally recognized days of rest or at night or after the normal working hours, the assistants to the Engineer's Representative perform supervision of the Works, the additional supervision cost based on hourly rates shall be determined by the Engineer after due consultation with the Procuring Entity and the Contractor, which shall be paid by the Contractor to the assistants through the Engineer's Representative; this mode of compensation shall be applicable also under Sub-Clause 46.1.

48.2 TAKING OVER OF SECTIONS OR PARTS

For the purposes of para (a) of this Sub-Clause, separate Times for Completion shall be provided in the Appendix-A to Bid "Special Stipulations"..

51.2 INSTRUCTIONS FOR VARIATIONS

At the end of the first sentence, after the word "Engineer", the words "in writing" are added.

52.1 VALUATION OF VARIATIONS

In the tenth line, after the words "Engineer shall" the following is added:

Within a period not exceeding one-eighth of the completion time subject to a minimum of 56 days from the date of disagreement whichever is later.

53.4 FAILURE TO COMPLY

This Sub-Clause is deleted in its entirety.

54.3 CUSTOMS CLEARANCE

Customs Clearance of the Contractors equipment, materials, and other things required for the Works will be the responsibility of the Contractor.

54.5 CONDITIONS OF HIRE OF CONTRACTOR'S EQUIPMENT

The following paragraph is added:

The Contractor shall, upon request by the Engineer at any time in relation to any item of hired Contractor's Equipment, forthwith notify the Engineer in writing the name and address of the Owner of the equipment and shall certify that the agreement for the hire thereof contains a provision in accordance with the requirements set forth above.

The Sub-Clauses 59.4 & 59.5 are deleted and substituted with the following:

59.4 PAYMENTS TO NOMINATED SUBCONTRACTORS

The Contractor shall pay to the nominated Subcontractor the amounts which the Engineer certifies to be due in accordance with the subcontract. These amounts plus other charges shall be included in the Contract Price in accordance with Clause 58 (Provisional Sums), except as stated in Sub-Clause 59.5 (Certification of Payments).

59.5 CERTIFICATION OF PAYMENTS & NOMINATED SUBCONTRACTORS

Before issuing a Payment Certificate, which includes an amount payable to a nominated Subcontractor, the Engineer may request the Contractor to supply reasonable evidence that the nominated Subcontractor has received all amounts due in accordance with previous Payment Certificates, less applicable deductions for retention or otherwise. Unless the Contractor:

- a) Submits reasonable evidence to the Engineer, or
- b) (i) Satisfies the Engineer in writing that the Contractor is reasonably entitled to withhold or refuse to pay these amounts, and
 - (ii) Submits to the Engineer reasonable evidence that the nominated Sub-contractor has been notified of the Contractor's entitlement.

Then the Procuring Entity / Employer may (at his sole discretion) pay direct to the nominated Subcontractor, part or all of such amounts previously certified (less applicable deductions) as are due to the nominated Subcontractor and for which the Contractor has failed to submit the evidence described in sub-paragraphs (a) or (b) above. The Contractor shall then repay, to the Procuring Entity / Employer, the amount, which the nominated Subcontractor was directly paid by the Procuring Entity / Employer.

60.1 MONTHLY STATEMENTS

In the first line after the word "shall", the following is added:

"On the basis of the joint measurement of work done under Clause 56.1,"

In Para (c) the words “the Appendix to Tender” are deleted and substituted with the words “Sub-Cause 60.11 (a) to (f) hereof”. 60.2 Monthly Payments

In the first line, “28” is substituted by “14”.

60.2 MONTHLY PAYMENTS

Sub-Cause 60.2 is deleted and substituted as under:

The said statement shall be approved or amended by the Engineer in such a way that, in his opinion, it reflects the amounts due to the Contractor in accordance with the Contract, after deduction, other than pursuant to Clause – 47, of any sums which may have become due and payable by the Contractor to the Procuring Entity. In cases where there is a difference of opinion as to the value of any item, the Engineer’s view shall prevail.

Within 28 days of receipt of the monthly statement referred to in Sub-Clause 60.1, the Engineer shall determine the amounts due to the Contractor and shall issue to the Procuring Entity and the Contractor a certificate herein called “ Interim Payment Certificate”, certifying the amounts due to the Contractor.

Provided that the Engineer shall not be bound to certify any payment under this Sub-Clause if the net amount thereof, after all retentions and deductions, would be less than the Minimum Amount of Interim Payment Certificates stated in the Appendix – A to Bid.

Notwithstanding the terms of this Clause or any other Clause of the Contract, no amount will be certified by the Engineer for payment until the performance security has been provided by the Contractor and approved by the Procuring Entity / Employer.

60.10 TIME FOR PAYMENT

The text is deleted and substituted with the following:

The amount due to the Contractor under any Interim Payment Certificate issued by the Engineer pursuant to this Clause, or to any other terms of the Contract, shall , subject to Clause – 47, be paid by the Procuring Entity to the Contractor within 30 days after such Interim Payment Certificate has been jointly verified by Procuring Entity / Employer and Contractor, or, in the case of the Final Certificate referred to in Sub-Clause 60.8, within 60 days after such Final Payment Certificate has been jointly verified by Procuring Entity and Contractor; Provided that the Interim and Final Payments shall be caused subject to availability of funds.

The following Sub-Clause 60.11 and 60.12 are added:

60.11 SECURED ADVANCE ON MATERIALS

- a. The Contractor shall be entitled to receive from the Procuring Entity / Employer Secured Advance against an indemnity bond acceptable to the Procuring Entity / Employer of such sum as the Engineer may consider proper in respect of non-perishable materials brought at the Site but not yet incorporated in the Permanent Works provided that:

- (1) The materials are in accordance with the Specifications for the Permanent Works;
 - (2) Such materials have been delivered to the Site and are properly stored and protected against loss or damage or deterioration to the satisfaction of the Engineer but at the risk and cost of the Contractor;
 - (3) The Contractor's records of the requirements, orders, receipts and use of materials are kept in a form approved by the Engineer, and such records shall be available for inspection by the Engineer;
 - (4) The Contractor shall submit with his monthly statement the estimated value of the materials on Site together with such documents as may be required by the Engineer for the purpose of valuation of materials and providing evidence of ownership and payment therefor;
 - (5) Ownership of such materials shall be deemed to vest in the Procuring Entity / Employer and these materials shall not be removed from the Site or otherwise disposed of without written permission of the Procuring Entity / Employer; and
 - (6) The sum payable for such materials on Site shall not exceed 75 % of the (i) landed cost of imported materials, or (ii) ex-factory / ex-warehouse price of locally manufactured or produced materials, or (iii) market price of other materials.
- b. The recovery of Secured Advance paid to the Contractor under the above provisions shall be effected from the monthly payments on actual consumption basis.

60.12 FINANCIAL ASSISTANCE TO CONTRACTOR

Financial assistance shall be made available to the Contractor by the Procuring Entity by adopting the following procedure for Mobilization Advance payment:

- 1) An interest-free Mobilization Advance up to 10 % of the Contract Price stated in the Letter of Acceptance shall be paid by the Procuring Entity to the Contractor in two equal parts upon submission by the Contractor of a Mobilization Advance Guarantee/Bond for the full amount of the Advance in the specified form from a Scheduled Bank in Pakistan acceptable to the Procuring Entity:
 - a) First part (5% of the Contract Price) within 28 days after receipt of the Bank Guarantee against the Advance duly verified from the Bank by the Procuring Entity, after signing of the Contract Agreement; and
 - b) Second part (5% of the Contract Price)
 - 60 % of this second part (i.e., 3% of the Contract Price) shall be paid within 42 days from the date

of payment of the first part, subject to the satisfaction of the Engineer as to the state of mobilization of the Contractor.

- The remaining 40 % of this second part (i.e., 2% of the Contract Price) shall be paid within 90 days from the date of payment of the first part subject to establishment of Contractor's Camp and Ste office facilities for the Procuring Entity, the Engineer representative and their assistants.
- 2) The bank guarantee shall remain valid and in force until the mobilization advance is repaid in full.
- 3) At any time, the bank guarantee shall be valid for an amount not less than the amount of the original Mobilization Advance less any partial repayment of that Advance which may have been affected. The Contractor shall inform the guaranteeing bank, by letter counter signed by the Procuring Entity, of the required amount of the guarantee from time to time. Reduction of the amount shall not be made without such authorizing letter.
- 4) The Procuring Entity shall be empowered to call in the guarantee in whole or in part(s) if the Contractor defaults in the repayment (s) for any reason.
- 5) Recovery of the Mobilization Advance shall be made by deduction in instalments from Interim Payment Certificates. Deduction shall be made after the deduction of Retention Money. However, regard less of the frequency or amount of Interim Payment Certificates, repayment of the Mobilization Advance shall be in equal monthly instalment equivalent to original Mobilization Advance / (Number of Months in original Time for Completion minus six). The first instalment shall fall due four months following the Order to Commence, thereafter each month until full repayment has been affected. Recovery of the full amount of Advance shall be ensured at least two months prior to expiry of the Time for Completion as per clause 43 hereof.
- 6) Where an Extension of Time is granted to the Procuring Entity's default under Sub-Clause 6.3 or under Clause 42 of the Conditions of Contract, the Procuring Entity shall, on the request of the Contractor, defer repayment(s) of Mobilization Advance and consequently extend the period of repayment. for a period not exceeding the actual Extension of Time given or the Engineer's assessment for the time being of any Ex tension of Time which may be due. The value of monthly repayments will not be altered.
- 7) In the event that the amount of monies certified and due to the Contractor under the Contract at any time less than the total of due repayments of Mobilization Advance, the balance of the due repayments shall be paid to the Procuring Entity by the Contractor within seven days of demand by the Procuring Entity. If the balance is not so paid, the Procuring Entity shall be empowered to call in sufficient of the Mobilization Advance bank guarantee to cover the said balance.
- 8) If the payment of Mobilization advance in instalments is delayed from the Schedule dates due to non-availability or shortage of funds from the Procuring Entity then in such case, the Contractor shall not be entitled to claim interest on the delayed payment as financing charges.

61.1 APPROVAL ONLY BY DEFECTS LIABILITY CERTIFICATE

The text is deleted and substituted with the following:

Only the Defects Liability Certificate, referred to in Clause 62, shall be deemed to constitute completion and approval of the Works.

This Advance shall be recovered in equal instalments; first instalment at the expiry of third month after the date of payment of first part of Advance and the last instalment two months

63.1 DEFAULT OF CONTRACTOR

The following para is added at the end of the Sub-Clause:

Provided further that in addition to the action taken by the Procuring Entity / Employer against the Contractor under this Clause, the Procuring Entity / Employer may also refer the case of default of the Contractor to Pakistan Engineering Council for punitive action under the Construction and Operation of Engineering Works Bye-Laws 1987, as amended from time to time.

65.2 SPECIAL RISKS

The text is deleted and substituted with the following:

The Special Risks are the risks defined under Sub-Clause 20.4.

65.4 PROJECTILE MISSILE

Delete the words "whenever and wherever occurring" in line 2 and add "on or near the Site" after the words "explosive of war" in line 3.

67. 3 ARBITRATION

In the sixth to eight lines, the words "shall be finally settled..... appointed under such Rules" are deleted and substituted with the following:

'shall be finally settled under the provisions of the Arbitration Act, 1940 as amended or any statutory modification or re-enactment thereof for the time being in force.'

The following paragraph is added:

The place of arbitration shall be Peshawar, Khyber Pakhtunkhwa.

68.1 NOTICE TO CONTRACTOR

The following paragraph is added:

For the purposes of this Sub-Clause, the Contractor shall, immediately after receipt of Letter of Acceptance, intimate in writing to the Procuring Entity / Employer and the Engineer by registered post, the address of his principal place of business or any change in such address during the period of the Contract.

68.2 NOTICE TO PROCURING ENTITY / EMPLOYER AND ENGINEER

For the purposes of this Sub-Clause, the respective addresses are:

a) **The Procuring Entity / Employer**

The Procuring Entity / Employer is “**Directorate General Small Dams, Irrigation Department Government of Khyber Pakhtunkhwa Plot No. 27, Street No. 12, Sector E-8, Phase-VII, Hayatabad Peshawar**”.

b) The Engineer

The Engineer is “**Director (South), Directorate General Small Dams, Irrigation Department, Khyber Pakhtunkhwa.**”

c) Engineer’s Representative

The Engineer’s Representative will be notified subsequently.

69.1 DEFAULT OF PROCURING ENTITY / EMPLOYER

(a) In second line substitute "56 days" for "28 days".

(b) Delete paragraph (b) and substitute the following.

Interfering with or obstructing or refusing any required approval to the issue of any such certificate, except that the acts of the Procuring Entity set out in Clause 2 hereof shall not be construed as such interference, obstruction or refusal, or,

(c) Delete paragraph (c) and re-number paragraph (d) as (c).

70.1 INCREASE OR DECREASE OF COST

Sub-Clause 70.1 is deleted in its entirety, and substituted with the following:

The amounts payable to the Contractor, pursuant to Sub-Clause 60.1, shall be adjusted in respect of the rise or fall in the cost of labor, materials, and other inputs to the Works, by applying to such amount the formula prescribed in this Sub-Clause. The price adjustment shall not be applied to NSI items.

(a) Other Changes in Cost

To the extent that full compensation for any rise or fall in costs to the Contractor is not covered by the provisions of this or other Clauses in the Contract, the unit rates and prices included in the Contract shall be deemed to include amounts to cover the contingency of such other rise or fall of costs.

(b) Adjustment Formula

The price adjustment formula shall not be applied before expiry of one year from date fixed for receiving of tenders and price of works and goods done or delivered during that period are not subject to escalation.

The adjustment to the monthly statements in respect of changes in cost shall be determined from the following formula:-

$$P_n = A + b \frac{L_n}{L_o} + c \frac{M_n}{M_o} + d \frac{E_n}{E_o} + \dots$$

Where:

“P_n” is a price adjustment factor to be applied to the amount for the payment of the work carried out in the subject month, determined in accordance with Paragraph 60.1 (a), and with Paragraphs 60.1 (b) and (e), where any variations and daywork are not otherwise subject to adjustment;

“A” is a constant, specified in Appendix-C to Bid, representing the nonadjustable portion in contractual payments;

b, c, d, etc., are weightages or coefficients representing the estimated proportion of each cost element (labour, cement and reinforcing steel etc.) in the Works or Sections thereof, net of Provisional Sums and Prime Cost; the sum of A, b, c, d, etc., shall be one;

“L_n”, “M_n”, “E_n”, etc., are the current cost indices or reference prices of the cost elements for month “n”, determined pursuant to Sub-Clause 70.1(d), applicable to each cost element; and

“L_o”, “M_o”, “E_o”, etc., are the base cost indices or reference prices corresponding to the above cost elements at the date specified in Sub-Clause 70.1(d).

(c) Sources of Indices and Weightages

The sources of indices shall be those listed in Appendix-C to Bid, as approved by the Engineer. As the proposed basis for price adjustment, the Contractor shall have submitted with his bid the tabulation of Weightages and Source of Indices if different than those given in Appendix-C to Bid, which shall be subject to approval by the Engineer.

(d) Base, Current, and Provisional Indices

The base cost indices or prices shall be those prevailing on the day 28 days prior to the latest date for submission of bids. Current indices or prices shall be those prevailing on the day 28 days prior to the last day of the period to which a particular monthly statement is related. If at any time the current indices are not available, provisional indices as determined by the Engineer will be used, subject to subsequent correction of the amounts paid to the Contractor when the current indices become available.

(e) Adjustment after Completion

If the Contractor fails to complete the Works within the Time for Completion prescribed under Clause 43, adjustment of prices thereafter until the date of completion of the Works shall be made using either the indices or prices relating to the prescribed time for completion, or the current indices or prices, whichever is more favorable to the Procuring Entity / Employer, provided that if an extension of time is granted pursuant to

Clause 44, the above provision shall apply only to adjustments made after the expiry of such extension of time.

(f) Weightages

The weightages for each of the factors of cost given in Appendix-C to Bid shall be adjusted if, in the opinion of the Engineer, they have been rendered unreasonable, unbalanced, or inapplicable as a result of varied or additional work executed or instructed under Clause 51. Such adjustment(s) shall have to be agreed in the variation order.

72.2 CURRENCY PROPORTIONS

All payments shall be in local currency only.

72.3 CURRENCIES OF PAYMENT FOR PROVISIONAL SUMS

All payments shall be in local currency only.

The following Sub-Clauses 73.1, 73.2, 74.1, 75.1, 76.1, 77.1 and 78.1 are added:

73.1 PAYMENT OF INCOME TAX

The Contractor, Subcontractors and their employees shall be responsible for payment of all their income tax, super tax and other taxes on income arising out of the Contract and the rates and prices stated in the Contract shall be deemed to cover all such taxes.

73.2 CUSTOMS DUTY & TAXES

- (i) The prices tendered by the Contractor shall include all import license fees, custom duties, excise duties, sale taxes, surcharges, business taxes, income and other taxes that are levied according to the laws and regulations of Pakistan on the Contractor's Equipment, materials, and supplies (both permanent, temporary and consumable) acquired for the purpose of the Contract and on the services performed under the Contract. Nothing in the Contract shall relieve the Contractor from his responsibility to pay any tax that may be levied in the country on profits made by him in respect of the Contract whatsoever is the rate of the tax during execution of the Works and payments for the same to the Contractor.
- (ii) KPPRA Sales Tax @ 4% on MRS 2025 will be paid by Contractor / Firm.

(iii) INTEGRITY PACT

If the Contractor or any of his Subcontractors, agents or servants is found to have violated or involved in violation of the Integrity Pact signed by the Contractor as Appendix-L to his Bid, then the Procuring Entity / Employer shall be entitled to:

- (a) Recover from the Contractor an amount equivalent to ten times the sum of any commission, gratification, bribe, finder's fee or kickback given by the Contractor or any

of his Subcontractors, agents or servants;

- (b) Terminate the Contract; and
- (c) Recover from the Contractor any loss or damage to the Procuring Entity / Employer as a result of such termination or of any other corrupt business practices of the Contractor or any of his Subcontractors, agents or servants.

The termination under Sub-Para (b) of this Sub-Clause shall proceed in the manner prescribed under Sub-Clauses 63.1 to 63.4 and the payment under Sub-Clause 63.3 shall be made after having deducted the amounts due to the Procuring Entity / Employer under Sub-Para (a) and (c) of this Sub-Clause.

75.1 TERMINATION OF CONTRACT FOR PROCURING ENTITY / EMPLOYER'S CONVENIENCE

The Procuring Entity / Employer shall be entitled to terminate the Contract at any time for the Procuring Entity / Employer's convenience after giving 56 days prior notice to the Contractor, with a copy to the Engineer. In the event of such termination, the Contractor:

- (a) shall proceed as provided in Sub-Clause 65.7 hereof; and
- (b) shall be paid by the Procuring Entity / Employer as provided in Sub-Clause 65.8 hereof.

76.1 LIABILITY OF CONTRACTOR

The Contractor or his Subcontractors or assigns shall follow strictly, all relevant labour laws including the Workmen's Compensation Act and the Procuring Entity / Employer shall be fully indemnified for all claims, damages etc. arising out of any dispute between the Contractor, his Subcontractors or assigns and the labour employed by them.

77.1 JOINT AND SEVERAL LIABILITIES

If the Contractor is a joint venture of two or more persons, all such persons shall be jointly and severally bound to the Procuring Entity / Employer for the fulfilment of the terms of the Contract and shall designate one of such persons to act as leader with authority to bind the joint venture. The composition or the constitution of the joint venture shall not be altered without the prior consent of the Procuring Entity / Employer.

78.1 DETAILS TO BE CONFIDENTIAL

The Contractor shall treat the details of the Contract as private and confidential, save in so far as may be necessary for the purposes thereof, and shall not publish or disclose the same or any particulars thereof in any trade or technical paper or elsewhere without the prior consent in writing of the Procuring Entity / Employer or the Engineer. If any dispute arises as to the necessity of any publication or disclosure for the purpose of the Contract, the same shall be referred to the decision of the Engineer whose award shall be final.

PART II –PARTICULAR CONDITIONS OF CONTRACT

Index	Clause
Alcoholic Liquor or Drugs	34.8
Arbitration	67.3
Arms and Ammunition	34.9
As-Built Drawings	6.7
Bonus for Early Completion of Works	47.3
Cash Flow Estimate to be Submitted	14.3
Commencement of Works	41.1
Compliance by Sub-Contractors	34.12
Conditions of Hire of Contractor's Equipment	54.5
Contractor's Representative	15.3
Co-operation with Other Contractors	31.3
Customs Clearance	54.3
Customs Duty and Taxes	73.2
Default of Contractor	63.1
Definitions	1.1
Detailed Program and Monthly Progress Report	14.5
Details to be Confidential	78.1
Disorderly Conduct	34.11
Procuring Entity's Risks	20.4
Local Personnel	16.4
Employment of Persons in the Service of Others	34.3
Engineer Not Liable	2.7
Employment of Engineer's Duties and Authority	2.1
Engineer's Representative	2.2
Epidemics	34.6
Exclusions	21.4
Failure to Comply	53.4
Festivals and Religious Customs	34.10
Financial Assistance to Contractor	60.11
Health and Safety	34.5
Housing for Labour	34.4
Increase or Decrease of Cost	70.1
Instructions for Variations	51.2
Insurance of Works and Contractor's Equipment	21.1
Insurance Company	25.5
Integrity Pact	74.1
Joint and Several Liability	77.1
Language Ability of Contractor's Representative	15.2
Language Ability of Superintending Staff of Contractor	16.3
Language(s) and Law	5.1
Liability of Contractor	76.1

Index	Clause
Lighting Work at Night	19.4
Monthly Payments	60.2
Monthly Statements	60.1
Notice to Contractor	68.1
Notice to Procuring Entity and Engineer	68.2
Payment of Income Tax	73.1
Payments of Nominated Subcontractors	59.4
Performance Security	10.1
Performance Security Binding on Variation and Changes	10.4
Priority of Contract Documents	5.2
Program to be Submitted	14.1
Rates of Wages and Conditions of Labour	34.2
Records of Safety and Health	35.2
Replacement of the Engineer	2.8
Reporting of Accidents	35.3
Safety Precautions	19.3
Secured Advance on Materials	60.11
Shop Drawings	6.6
Special Risks	65.2
Supply of Water	34.7
Taking Over of Sections or Parts	48.2
Termination of Contract for Procuring Entity's Convenience	75.1
Time for Payment	60.10
Use of Pakistani Materials and Services	36.6
Valuation of Variations	52.1

SPECIFICATIONS
SPECIAL PROVISIONS

SPECIFICATIONS SPECIAL PROVISIONS

SP-01 DESCRIPTION OF THE PROJECT

i) Location of the project

The Sumari Payan Dam is proposed on Sumari Toi in district Kohat. The dam site is approximately 13.5 miles South West of Kohat city and about 1 mile South-West of Sumari Payan village. Northing and Easting of the dam are 33° 27' 05" and 71° 15' 47" respectively.

ii) Site of works

The site of works is the area for Construction of Sumari Payan Dam within the right-of-way lines, boundaries and limits shown on the Drawings and such additional areas adjacent there to as may be designated under the Contract Documents, and all such areas and additional areas shall be included in the site as defined in Clause 1.1 of the Conditions of Contract.

Within the areas which may from time to time be defined as the Site, the Contractor shall carry out and perform the construction of the works and subject to the approval of the Engineer will be permitted to construct diversion works, road ways / access road, camps buildings and temporary works which he may be required for the construction of the works. If the Contractor wishes to use any land other than as aforesaid for construction of camps or for any other Contract purposes, the Contractor shall make all necessary arrangements with the owner thereof and shall bear all rentals or other costs connected therewith.

The Employer will give to the Contractor possession of as much of the areas designated and defined as the site and shown on the drawings as may be required to implement the works when the Engineer's order to commence work is given.

The site is subjected to seismic disturbances, rain storms and floods. Attention is drawn to the necessity for allowing for these factors in the design and specification of temporary works, materials, plant and equipment for which the Contractor may be responsible.

SP-02 PROJECT FEATURES**i) Work by Contractor**

The scope of work under this contract consists of furnishing all plant, labour, equipment, superintendence and other services and facilities required for completion and maintenance of Sumari Payan Dam, as required in the contract. The contractor shall also furnish all the materials required for the works. The project features under this contract will consist of Main Dam, Spillway, Outlet Structure, Irrigation Channel & Structures, Relocation of Road and Chowkidar Hut,. Following are the principal features of the works to be persecuted, which shall be of capacities and sizes as shown in the contract document.

1) Main Dam

Earth core Rock fill dam with positive cut off is proposed and designed for Sumari Payan Dam keeping in view the availability of materials and site topography. The dam is about 2066 ft. long at the top and 71 ft. maximum height above nullah bed. The embankment sections will have 2.5H: 1 upstream slope and 2H: 1V downstream slope with crest width of 25 ft.

2) Spillway

The spillway of a 211.7 ft. width with crest elevation at 1825 ft. a.m.s.l is, designed for 500 years return period routed outflow flood discharge of 38,508 cusecs with a maximum flood surcharge of 7.5.7 ft.

3) Outlet Structure

An intake structure is provided of about 2.5 ft dia pipe with intake structure in upstream side and a valve chamber and an impact type stilling basin and the stilling basin well on the downstream side.

4) Irrigation Canal and Affiliated Structures

An irrigation system comprising of canal and structures shall be constructed to carry the design discharge to the command area of 2200 acres. The design discharge of the canal is 12.77 cfs and length of Main canal is 19,000 ft and length of Minor canal is 9,300 ft.

5) Approach Road

Approach Road to the dam site shall be constructed by the Contractor using the existing road in such a way that shortest possible path that requires

minimum excavation is constructed.

Details can be seen in the bid drawings (Vol. II)

SP-03 DRAWINGS

i) Drawings in Contract

The Drawings entitled Sumari Payan Dam herein after referred to as Bid Drawings; show the scope of work to be performed by the Contractor. The Bid Drawings shall not be used as a basis for fabrication or construction but may be used for planning, scheduling and placing preliminary orders for materials, subject to corrections based on the future issue of Drawings as provided under sub-clause SP – 03 (ii), Construction Drawings. Any other drawings which are issued as Addenda before opening of Bids shall become part of this list.

ii) Construction Drawings

After award of Contract, the Bid Drawings will be replaced by drawings issued by the Engineer for construction, with the supplementary specifications as may be necessary. The Drawings issued for construction will include Bid Drawings reissued, Bid Drawings as may be modified, and additional drawings as required to develop in greater detail the construction required and shall be referred to hereinafter as Construction Drawings. The Construction Drawings will be drawings from which shop erection, concrete placing, formwork or other detailed drawings shall be prepared by the Contractor. The work shall be executed in conformity with the Construction Drawings.

iii) Definition of Term Drawings

The term Drawings as used throughout the Specifications apply to both the Bid Drawing defined in sub-clause SP – 03 (i), Drawings in Contract and to the drawings issued for construction as described in sub-clause SP – 03 (ii), Construction Drawings.

iv) Checking of Drawings

The Contractor shall check all Construction Drawings carefully as soon as practicable after receipt thereof and shall promptly advise the Engineer of any errors or omission.

v) Copies of Drawings and Specifications

Drawings and Specifications will be issued to the Contractor as follows:

1. Bid Drawings

Sets of Bid Drawings will be provided at cost of reproduction upon written request of the contractor.

2. New Construction Drawings

Two copies of each drawing (free of charge) will be provided to the Contractor.

3. Specifications

Sets of Specifications will be provided at cost fixed by Engineer upon written request of the Contractor.

vi) Drawings to be furnished by the Contractor**1. Shop Drawings**

All shop drawings required for the work (except reinforcing steel bending and cutting drawings and such drawings as are specified to be furnished by others under separate contracts) including field erection layout and construction detail drawings shall be furnished by the Contractor for approval of the Engineer. All more detail drawings are necessary to complete any part of the work, such detailed drawing shall be prepared by the Contractor and submitted to the Engineer for approval. All drawings shall be completed and shall be submitted in due time and in logical order to facilitate proper coordination. All drawings submitted and approved will form part of the Contract.

2. Lift Drawings

Not less than fifteen calendar days prior to starting construction of any lift or other placement of concrete the Contractor shall submit to the Engineer for approval, detailed drawings hereinafter called lift drawings to such scale as to show clearly all recesses openings and embedded work including embedded structural, mechanical and electrical items, in each lift or placement in sufficient detail for proper prosecution of the work. Lift drawings shall be submitted for every lift or other placement of concrete.

3. Camp Layout Drawings

Three prints of drawings showing the layout of the Contractor's camps with locations of his offices, labour camps, workshops, stores, sheds, yards and the constructional plant which the Contractor proposes to use on the works shall be submitted by the Contractor to Engineer for review. The drawings shall be submitted sufficiently in time to permit adequate review by the Engineer. Two sets of the drawings will be retained by the Engineer and one set will be returned to the Contractor with comments.

4. Other Drawings

Drawings showing proposed methods of construction for Temporary Works and other drawings additional to those referred to hereinabove, required by the Specifications, shall also be submitted to the Engineer for approval.

5. Ownership of Drawings

All the drawings, bill of materials and any other information or documents furnished by the Contractor shall become the property of the Employer and shall be non-returnable.

vii) Submission and Approval

1. Drawings for Approval

The Contractor shall send drawings requiring approval obtaining of the Engineer by air mail as follows:

Project Manager	1 reproducible and 2 prints
-----------------	--------------------------------

With copy to

Resident Engineer	One Print
-------------------	-----------

Within fifteen calendar days after receipt, the Engineer will send one copy to the Contractor marked "Approved". "Approved Except as Noted" or "Returned for Correction". The notation "Approved" and "Approved Except as Noted" will authorize the Contractor to proceed with the fabrication of the materials and equipment or construction work covered by such drawings subject to the corrections, if any indicated thereon.

When prints of drawings have been "Returned for Correction" the Contractor shall make the necessary revisions on the drawings and shall resubmit prints for approval in the same manner as for new drawings. Every revision made during the life of the Contract shall be shown by number, date and subject in a revision block.

2. Work Prior to Approval

Any work done prior to the approval of drawings shall be at the Contractor's risk. The engineer shall have the right to request any additional details and to require the Contractor to make any changes in the design which are necessary to conform to the provisions and intent of these Specifications without additional cost to the Employer. The approval of the drawings by the Engineer shall not be construed as a complete check but satisfactory. Approval by the Engineer of the Contractor's drawings shall not be held to

relieve the Contractor of the obligation to meet all the requirements of these Specifications or of the responsibility for the correctness of the Contractor's drawings or of the responsibility for correct fit of assembled parts in final position or of the responsibility for the adequacy of method of construction.

3. Sequence of Submission

The sequence of submission of all drawings shall be such that all information is available for checking each drawing when it is received. All drawings submitted for approval shall be provided with a blank white space approximately 100 mm in height by 200 mm in width near the lower right-hand corner to be used for notations by the Engineer.

4. Approved Drawings

All approved Drawings and data shall form part of the Contract. If revisions are made after a drawing has been approved, the Contractor shall furnish for approval additional copies as specified for the initial submission, subsequent to each revision. The contractor shall distribute approved drawings by air mail to the addresses as follows:

- | | |
|---|--------------------------------|
| 1. Director General Small Dams
Irrigation Department
Government of Khyber Pakhtunkhwa | 1 reproducible and
2 prints |
| 2. Director (South), Directorate General Small Dams,
Irrigation Department
Government of Khyber Pakhtunkhwa | 2 prints |
| 3. Project Manager | 1 reproducible and
2 prints |
| 4. Resident Engineer | Two prints |

The distribution may be varied in the course of the Contract.

viii) Record Drawings

The Contractor shall during the progress of the work, keep a record of all changes in and corrections to the designs and layouts shown on the drawings. The Contractor shall prepare the record drawings under the supervision of the Engineer. The Contractor shall furnish to the Engineer three copies of all the record drawings after approval by the Engineer.

ix) Drawings, Data, Correspondence – Language

Unless otherwise approved by the Engineer all drawings, data correspondence and

other submissions made by the contractor shall be in the English language.

SP-04 LAYOUT OF WORK AND SURVEYS

i) Reference Points, Lines and Levels

The Engineer will layout a reference line or lines in the field with accompanying points and bench marks with the assistance of surveyors / equipment, labour and materials provided by the Contractor. The Contractor shall establish all permanent reference points for construction control as a consequence of this work.

ii) Verification

The Engineer may make check as the work progresses to verify lines and grades established by the Contractor and to determine the conformance of the work as it progresses with the requirements of Specifications and Drawings. Such checking by the Engineer shall not relieve the contractor of his responsibility to perform all work in accordance with the Drawings and Specifications and the lines and grades given therein.

SP-05 ABBREVIATIONS OF STANDARDS

Standard specifications and codes of the following listed authorities wherever cited herein are referred to by use of the acronyms shown below. All materials and workmanship shall comply with requirements of latest revisions of applicable codes.

1.	American National Standards Institute, Inc.	ANSI
2.	American Society for Testing and Materials	ASTM
3.	American Association of State Highway & Transport Officials	AASHTO
4.	British Standards Institution	BS
5.	American Standards Association	ASA
6.	American Concrete Institute	ACI
7.	United States Bureau of Reclamation	USBR
8.	Steel Structures Painting Council	SSPC
9.	National Electrical Manufacturers Association	NEMA
10.	Insulated Power Cable Engineers Association	IPCEA
11.	American Society of Mechanical Engineers	ASME
12.	American Welding Society	AWS

13.	American Water Works Association	AWWA
14.	American Institute of Steel Construction	AISC
15.	Federal Highway Administration	FHWA
16.	American Institute of Architects	AIA
17.	American Society of Civil Engineers	ASCE
18.	American Wood Preservers Association	AWPA
19.	American Wire Gauge	AWG

SP-06 STANDARDS OTHER THAN THOSE SPECIFIED

Where requirements for materials or equipment are specified by reference to a standard which has its origin in one country, it is not the intention to restrict the requirements solely to that standard and that country. Other standards including standards of other countries will be accepted provided the requirements thereof in the sole opinion of the Engineer are at least equal to the requirements of the standard specified. The Contractor may propose to the Engineer an equivalent standard other than that specified in which case he shall submit the proposed standard and all other information required by the Clause SP-07 and shall submit written proof that his proposed standard is equivalent in all significant respects to the standard specified.

SP-07 APPROVAL OF MATERIALS, EQUIPMENT AND WORKMANSHIP**i. Manufacturer's Certificate of Compliance**

In the case of standard labelled stock products of standard manufacture, which have a record of satisfactory performance in similar work over a period of not less than two years, the Engineer may accept a notarized statement from the manufacturer certifying that the product conforms to the applicable specifications.

ii. Mill Certificates

In the case of materials for which such practice is usual, the Engineer may accept the manufacturer's certified mill and laboratory certificate.

iii. Testing Laboratory Certificate

The Engineer may accept a certificate from a commercial testing laboratory, satisfactory to him, certifying that the product has been tested within a period acceptable to the Engineer and that it conforms to the requirements of the Specifications.

iv. Service Record

If a demonstrable satisfactory service record is available for a material, certain specified tests may be waived by the Engineer.

v. Cost

The cost of any additional laboratory field and shop tests required through the resubmission of samples because of failure to comply with the Specifications shall be borne by the Contractor and will be deducted from any money due to him.

SP-08 INSPECTION

All material and equipment furnished and all work performed by the Contractor shall be subject to inspection by the Engineer at all times and in all states of completion both off-site and on-site. The Contractor shall furnish promptly, without additional charge, all facilities, labour and material reasonably needed by the Engineer to perform such inspection and tests. Selected materials and equipment may be inspected at the source e.g. borrow area, manufacturer's plant etc. as well as at the Site. Acceptance of materials and equipment or the waiving of inspection thereof shall in no way relieve the Contractor of the responsibility for furnishing materials and equipment meeting the requirements of the Contract.

SP-09 CONSTRUCTION SCHEDULE

i. Schedule to be provided

The Contractor shall carry out the Works in accordance with the dates specified in the Bid. Pursuant to Clause 14.1 of the Conditions of Contract, programme to be furnished, the Contractor shall within 15 days of the Order to Proceed submit to the Engineer for approval his proposed Schedule for construction and completion of the works.

ii. Form of Schedule

The schedule shall be in a form acceptable to the Engineer

Activities shown on the schedule shall consist not only of the actual construction operations but shall also include the submittal and approval of drawings and samples, procurement of materials and equipment, and installation and testing of major and critical items.

iii. Shipping of Materials and Equipment to the Site

In preparing the Schedule, the Contractor shall fully take into account the requirements, limitations and possibilities of ocean or air freight, inland and rail transportation etc. Progress of all shipments to the site shall be continuously monitored and the Contractor shall provide staff or agents to expedite all shipments and ensure compliance with the approved schedule.

iv. Approved Schedule

After initial approval by the Engineer the Contractor shall monitor the Schedule .and

regularly but at intervals not exceeding 90 days submit copies for the information of the Engineer. All revisions shall be accompanied by an explanation of the reasons for the change(s). Any required as a result of the Engineer's review or of changes in the overall project schedule shall be executed by the Contractor within 15 days of receipt of the Engineer's notice that such a revision is required. The schedule shall govern for such purposes as determination of extension of time, as the Engineer may require.

**SP-10 CONTRACTOR'S CAMP AND SITE FACILITIES TO BE PROVIDED BY THE CONTRACTOR
- CONSTRUCTION AND MAINTENANCE**

- i. The Contractor's camps shall comply with the rules of the Pakistan Labour Camp Rules, (latest edition), issued by the Pakistan Health, Welfare and Local Government Department and the requirements therein set forth.
- ii. The Contractor shall establish his own material testing laboratory near the dam site. He shall provide all equipment required to perform tests attached as Annex-1.
- iii. The Contractor with the approval of the Engineer shall provide and maintain such haulage and access roads, as are necessary for construction of the works. It shall also include access road to the dam site. Construction and maintenance of haul and access roads will not be measured for payment.
- iv. No separate payment will be made for any of the construction for Contractor's camps and utilities and their maintenance, and other facilities for use of the Engineer and Employer under these specifications, and all cost therefore shall be included in the unit rates bid for the items of the Bill of Quantities under this Contract.
- v. Vacating Camp
At such time when portions of the facilities provided by the Contractor are no longer required for the execution of the work, and in accordance with a schedule of time and the instructions furnished by the Engineer, the Contractor shall vacate and hand over to the employer in reasonably good condition, fair wear and tear considered, all buildings, housing, area improvements, utility systems, equipment, furniture and other facilities including furnishings and supplies constructed and provided as part of the facilities, except
The Contractor's construction and fabricating equipment, tools and supplies, and Such temporary buildings and facilities as may be specifically designated by the Engineer for removal by the Contractor.

SP-11 WATER FOR CONSTRUCTION AND OTHER USES

It is expressly expounded that the Contractor shall make his own investigations and arrangements for procurement and supply of water for construction and other uses. The Employer shall not accept any responsibility or entertain any claims by the Contractor due to non- availability of sufficient quantity or required quality of water.

SP-12 WEATHER CONDITIONS

The Contractor shall be deemed to have taken all possible weather and river flow conditions into account when preparing his bid and shall not be entitled to extra payment by reason of the occurrence or effect of excessive rainfall, drought, temperature or humidity, high winds, floods or any other meteorological phenomenon.

SP-13 ASSISTANCE FOR ENGINEER/CLIENT

- i. The Contractor shall provide for the use of the Engineer whenever required during the Contract, all chainmen, staff men, labourers, tradesmen, technicians, instruments, apparatus, protective head gear and other equipment as the Engineer deems necessary for the execution of his duties in connection with the Contract.

The Contractor shall be solely responsible for all such instruments and apparatus and shall ensure that they are at all times in good repair and adjustment.

All equipment other than expendable items shall revert to the Contractor on completion of the Works.

No separate payment will be made for the work done pursuant to this Clause.

SP-14 STORAGE AND USE OF EXPLOSIVES

- i. Explosives shall be stored, transported, handled and used in accordance with the law. The Contractor shall comply with all special rules and regulations that may be made by the authorities having jurisdiction, and by the Engineer, regarding construction of, and storage in magazines, precautions on blasting work, and the like. The Contractor will be held responsible to the Employer for all claims for damage caused.
- ii. Explosives and detonators shall not be transported in the same vehicle. Explosives shall be stored in suitable magazines in an approved location. Detonators shall be kept in a separate magazine. The magazine shall be plainly marked with large letters EXPLOSIVES — DANGEROUS in English and Urdu and shall be locked and guarded at all times. Keys to unlock the magazines shall be kept only by magazine keepers. Each magazine shall have around it a clear area suitably barricaded with a security fence.
- iii. Before starting any drilling and blasting of rock the Contractor shall submit his proposed plan in writing for such operations to the Engineer for approval, shall not deviate there from without the written permission of the Engineer. The Contractor's plan shall include statement of maximum safe distance; means of protection of concrete and other works and structures, all of which shall be compatible with good practices as indicated in the approved safety manuals and other approved publications. Approval by the Engineer of the Contractor's plan of operation shall in no case relieve the Contractor of full responsibility for the entire drilling and blasting operation, including the safety of persons and the work.
- iv. The Contractor shall satisfactorily cover shots in open cut excavation as may be required to prevent damage to the works and injury to persons, and shall take extra precautions on all blasting work when required by the Engineer. Flagmen shall be

employed by the Contractor to warn of pending blasts, and no radios shall be operated in the proximity of blasting operation.

The Contractor shall blast to the extent approved in a manner which will not open seams nor crack or otherwise damage the rock outside of the prescribed limits of excavation, nor unduly shake up the ground and make it unstable, nor injure concrete already placed or existing structures at the Site or in the vicinity thereof, nor in any way affect foundation and other rock and soil that is grouted. Whenever, in the Engineer's opinion, the Contractor's blasting operations may cause damage to rock against which concrete is to be placed, or rock that has been grouted, or otherwise cause damage, the Contractor shall drill shorter holes and use lighter charges or use mechanical rock removal or other suitable methods to complete the excavation.

SP-15 VENTILATION AND DUST CONTROL

The Contractor shall keep the air of the excavations and other spaces in a condition suitable for the health of men and clear enough for surveying operations.

SP-16 PHOTOGRAPHS

No photographs of the Site of the Works or any part thereof shall be published or otherwise circulated without the permission of the Engineer.

No such permission shall exempt the Contractor from complying with any statutory provisions in regard to the taking and publication of photographs.

SP-17 PROVIDES SECURITY GUARDS & MANPOWER FOR EMPLOYER & ENGINEER/ENGINEER REPRESENTATIVE OFFICES ALONG WITH SERVICE CHARGES.

Contractor shall provide security guards for the office of Employer and Engineer/Engineer representative to ensure proper security. The security guards shall perform the duties in three shifts. The guard provided should be from security agency have necessary approval of the Interior Ministry and Home Department of KP Government.

All the payments to the security agency shall be borne by contractor.

SP-18 DIRECTED AND REQUIRED

Unless otherwise stated, wherever in the Specifications or upon the Drawings, the words 'directed', 'required', 'permitted', 'ordered', 'designated', 'prescribed' or words of like import are used it shall be understood that the 'direction', 'requirement', 'permission', 'order', 'designation' or

'prescription' of the Engineer is intended and similarly the words approved acceptable satisfactory or words of like import shall mean approved by or acceptable or satisfactory to the Engineer.

SP-19 CONTRACTOR TO COOPERATE WITH OTHERS

Pursuant to Clause 31.2 of the Conditions of Contract, the Contractor shall coordinate his work with that of other Contractors/Sub-Contractors at the Site to whatever extent may be necessary to complete the Project in accordance with the Schedule, the Drawings and Specifications and the requirements of the Engineer. Should a disagreement or dispute arise between the Contractor, and any of the other Contractor / Sub-Contractors, the same shall be submitted without delay to the Engineer for his decision. Upon such decision, the Contractor, and the other Contractor / Sub Contractors shall proceed with the work in accordance therewith, immediately.

SP-20 PROGRESS REPORTS AND PHOTOGRAPHS

On the Tenth day of each month the Contractor shall submit four copies of a detailed written report in a form acceptable to the Engineer of the progress of the work during the preceding month. The report shall show, among such other data as the Engineer may request, the percentage of each type of work completed during the month and the total percentages of completion as of the date of the report. The Contractor shall also supply to the Engineer 8"x10" colour photographs of the work in progress throughout the Contract period. The photographs shall be taken at the start and completion of each major component of the work and at other times as directed by the Engineer to show the progress of the Project and each feature thereof. The Contractor shall provide one negative and four glossy prints of each photograph monthly. Only clear, sharply defined photographs will be accepted. No separate payment will be made for work done pursuant to this Clause.

SP-21 SAFETY AND HEALTH

i. General

In prosecuting the work, the Contractor shall provide working conditions on each operation that shall be safe and healthful as the nature of that operation permits. The crushing of rock, the dumping of stone, the mixing of concrete and handling of cement, steel and other materials shall be so conducted that these operations will not be injurious to life, limb or health. All work shall be performed in: accordance with applicable local and national law, codes requirements and regulations including safety, health, welfare of persons and others.

ii. Accident and Fire Prevention

The Contractor shall enforce rules and regulations for the safe prosecution of the work

in order to avoid preventable accidents and to minimize injuries to his employees and those of the Employer, the Engineer and other third Parties work areas shall be adequately posted with safety signs and posters. Machinery and equipment shall be guarded and all hazards eliminated. All reasonable precautions shall be taken against fire, and provisions shall be made for the expeditious extinguishing thereof.

In addition to the reports which the Contractor may be required to file under the law he shall file with the Engineer on or before the tenth day of each month, a report giving the total force employed on this Contract in man-days during the previous calendar month, the number and character of all accidents resulting in loss of time, and any other information on classification of employees, injuries received on the work and disabilities arising there from that may be required by the Engineer.

During the entire period of his operations at the site, the Contractor shall be required to make arrangements for providing emergency medical treatment including first aid treatment and approved qualified personnel to administer such treatment to all injured persons including the Employer's and Engineer's personnel. The Contractor shall designate one or more approved competent licensed physicians who shall at all times be ready to supply medical and surgical services. The Contractor shall submit for the approval of the Engineer and upon such approval install a means of rapidly summoning the physicians to the site of an accident or fire.

SP-22 RESTRICTION OF WORKMEN TO SITE

The Contractor shall restrict his work men to the Site and prevent trespass into adjoining property and completed parts of the works and shall take all necessary precautions to prevent and indemnify the Employer against any damages arising from nuisance of any kind.

SP-23 PROTECTION CHARGES AND TRIBAL ROYALTIES

The Contractor or any of his sub-contractors shall be responsible for the payment of protection charges and tribal royalties, if so required to be paid in accordance with any locally established tradition custom or practice and the rates and prices stated in the priced Bill of Quantities shall be deemed to cover all such protection charges, tribal royalties and other such payments.

SP-24 MOBILIZATION ADVANCE

An interest free mobilization advance is to be paid under Clause 60.12 of the conditions of Contract Part-II, to compensate the Contractor for operation including, but not limited to, any

necessary mobilization expenses for all equipment, related components and supplies and delivery to the Site; those necessary for the interim salaries and the movement or personnel, household effects, supplies and incidentals to the project site, for site preparation, the establishment of workshops, storage, offices, accommodation, services and other facilities deemed to be required under the Contract; and for any other work and operation which must be performed or costs which must be incurred prior to the initiation of works under the Contract. The advance payment shall be repaid by the Contractor in accordance with Clause 60.12 of condition of Contract Part-II.

SP-25 COMMUNICATION TO THE ENGINEERS

The Contractor shall address all communications as follows:

1. The Engineer

Director (South), Directorate General Small Dams, Irrigation Department , Government of Khyber Pakhtunkhwa.

2. Engineer's Representative

With copy to

3. Resident Engineer

SP-26 WORK DONE AFTER COMPLETION DATE

The contractor's obligation to provide facilities and services to the personnel and officers of the Employer, the Engineer and other contractors will terminate upon date of the final Certificate of Completion. However, if directed by the engineer, the contractor shall continue such work to the extent directed by the Engineer for an additional period of up to twelve months. Payment for such additional work will be made under the provisional sum for the item, Continuation of the Contractor-Provided Services. No payment under this Clause will be made for those parts of the Contractor's camp and other facilities, which he requires for his own use during the Defects Liability Period.

The aforementioned schedule of time and instructions will require handing over of certain portions of the facilities on the date of final Certificate of Completion. The Contractor will be permitted to retain possession of and use such portions of the camp as he may reasonably require to carry out his obligations and work remaining under the Contract after the date of the final Certificate of Completion.

SP-27 MEASUREMENT AND PAYMENT

General

Unless specifically provided, all works/services required to be provided under Special Provisions, shall be deemed to be included in the unit rates of Bill of Quantities and no separate measurement or payment shall be made.

SP-28 DECISION OF EMPLOYER

In these Clauses, if there is anything repugnant to the conditions of Contract then decision of the Employer shall be final.

SP-29 ADDITIONS TO AND DELETIONS FROM CLAUSES

Employer has the right of making any additions to and/or deletions from any conditions of contract special provisions, Technical Specifications and any other document forming a part of Bid/Contract Documents.

SP-30 CONSTRUCTION ITEMS

Employer has the right to add or delete any item of Construction.

**SPECIFICATIONS-
TECHNICAL PROVISIONS**

TECHNICAL SPECIFICATIONS

TABLE OF CONTENTS

SECTION - 1	CARE AND HANDLING OF WATER	122
SECTION - 2	EXCAVATION	124
SECTION - 3	CONSTRUCTION OF EARTHFILL	139
SECTION - 4	EMBANKMENT INSTRUMENTATION	160
SECTION - 5	PLAIN AND REINFORCED CONCRETE	163
SECTION - 6	BRICK WORK	192
SECTION - 7	REINFORCED CEMENT CONCRETE PIPE	194

SECTION – 1

CARE AND HANDLING OF WATER

1.1 GENERAL

This section covers the construction, maintenance, and required removal of structures and other facilities, and the performance of all work necessary to Care and Handling of spring water, river water, ground water, rain water, flood water, water from any other source, and local drainage in connection with entire contract i.e. during construction and maintenance periods so that such water does not interfere with the progress or affect the quality of construction. The work includes but is not limited to the following:

- i) Construction and Maintenance of coffer dams, Excavation of Diversion Channel,
- ii) Un-watering and handling of water behind coffer dams,
- iii) Dewatering of Foundations and Trenches,
- iv) Care and Handling of river work/water

1.2 COFFER DAMS

Coffer dam shall be constructed if required in accordance with the requirements and as specified herein or as directed by the Engineer. The proposed cofferdam section may be modified by the Contractor with the approval of the Engineer. The contractor may also increase the height of the cofferdam, if necessary, with the prior approval of the Engineer. All such construction if carried out shall be at the Contractor's expense. The construction shall be carried out in two stages. The construction in Stage-I shall be carried out on the left flank of main river up to elevation as directed by the engineer and the flow of the main river will pass through the right portion of the river channel. Embankment slopes facing river shall be protected by providing temporary stone protection Renomattress parallel to river flows up to the elevation as suggested by the engineer in charge. In Stage-II, construction of the dam in the river channel shall be started at the advent of dry season. Slope protection Renomattress will be removed before undertaking construction of dam in this stage. Embankment Dam in Stage-II construction must be completed in all respects prior to the next flood season. Engineer's approval shall be necessary for selection and demarcation of the borrow areas. The coffer dam shall be constructed by compacting river bed material. Each layer shall have a compacted thickness of 60 cm and shall be subjected to not less than two passes of a 10 ton tamping or other approved roller. Trapped water, if any, between the main dam and the cofferdams shall be drained off by any method proposed by the Contractor and approved by the Engineer. A constant watch shall be maintained by Contractor to check and close any leaks through the body or foundation of cofferdams. Dewatering arrangements including pumps, if required, shall be provided on the downstream of the cofferdams to keep the area dry while placing the embankment fill. Cofferdams shall be maintained till such time that the embankment has been completed in all respects.

The proposed method of Care and handling of Water is tentative, only for guidance and in no way limits the responsibility of the Contractor to provide risk - free care of water. The Contractor shall obtain the prior approval of the Engineer for any alternative method of care and handling of water. The Contractor shall also obtain the prior approval of the Engineer in respect of the date on which he proposes to start the Cofferdam filling, which date shall be as soon as practicable after the commencement of the dry season and in accordance with the Construction Schedule to be provided by the Contractor.

1.3 MEASUREMENT AND PAYMENT

Care and Handling of Water including Construction of Cofferdams Measurement will be made as lump sum of all work acceptably performed under Section SP 1.1 (i), (ii), (iii) and (iv) and which is not included for payment under any other item.

Payment will be made for the unit measured as provided above at the Contract lump sum price for Care and Handling of Water during construction and maintenance and shall constitute full compensation for all costs related to care and handling of water during construction and maintenance and other works for which payment is not made under other items, including review is not made under other items, including review of scheme shown on the Drawing, submission for approval, accepted adjustments of scheme, construction including excavation and fill for cofferdams and their maintenance dewatering including pumping, repair or replacement of damaged work due to flood and other waters, expense incidental to over topping of coffer dams, dewatering, re-excavation, refill and all other work related to the item. Payment for this item shall be made accordingly to the schedule of payment approved by the Engineer.

SECTION – 2

EXCAVATION

2.1 GENERAL

This section covers the excavation for embankment dam, spillway, approach channel, intake outlet structure, irrigation conduit, irrigation system, access road, chowkidar hut, borrow areas; dental excavation; other excavation not specified in other Sections; and disposal of all excavated materials except as the placement of material is covered in other Sections.

2.2 DRAWING PRESENTATION

In addition to the required excavation lines for permanent structures, the borrow areas may be used as sources of construction materials; results of field explorations at the required excavation and borrow areas including selected sources and estimated quantities of materials for use in various zones of the Dams. The information regarding sources and estimated quantities of materials for use in embankment as presented on the Drawings is not intended as a representation or a warranty and is presented only for the information of the Contractor. The Employer assumes no responsibility for any deductions, interpretations or conclusions drawn there-from. The Contractor will be required to review all data in Contract Documents, make his own investigations and studies necessary for a proposed plan of sources and distribution of excavated materials, and shall perform the work using sources and distribution that will result in the optimum project economy to the Employer and optimum progress consistent with requirements of the Drawings and Specifications. The Contractor shall propose his plan of excavated materials utilization for approval of the engineer. After the plan proposed by the Contractor is approved, the contractor may propose alterations to his plan for further approval of the Engineer as may be found necessary during the course of the work.

2.3 CLASSIFICATION OF EXCAVATION MATERIALS

a) General

The terms Rock and Earth are hereby defined when used for the purpose of classifying excavated materials for payment under the various Items of BOQ.

b) Rock

Rock is defined as all materials which, in the opinion of the Engineer, require blasting, or the use of metal wedges and sledgehammers, or the use of compressed air drilling for its removal, and which cannot be extracted by ripping with a tractor of at least 150 brake hp with a single rear mounted heavy duty ripper. In case of doubt the Engineer's decision will be considered final.

c) Earth

Earth shall mean all material except hard rock as defined above in subsection (b).

Earth shall include, but not necessarily be limited to soft rock river deposited material, all geologically recent materials such as alluvium and talus; all layers of earth which are cemented so that the earth becomes Conglomerate. Soft rock such as mudstone, siltstone, claystone, limestone, sandstone etc. shall be treated as Earth, if not covered under sub-section (b) above.

2.4 EXCAVATION OPEN CUT - GENERAL EXCAVATION METHODS

2.4.1 Excavation Methods

The Contractor shall perform all open cut excavation and grading to the final elevation lines and grades shown on the Drawings or approved by the Engineer. Excavation shall be performed by approved methods. The contractor shall make such trial excavations as are necessary to indicate the adequacy of the excavation methods. The rock excavation in the foundation of structures shall be done by excavation equipment and or such methods as Line Drilling, Pre Splitting or Cushion Blasting. The responsibility for the success of the excavation method shall rest with the contractor regardless of approval by the Engineer.

In general, for the earth and rock materials the Engineer will use his best endeavours to advise the Contractor at the loading areas regarding suitability of excavated materials for use in the embankment based on Engineer's examination prior to transportation to points of placement. Stock-Piling will not be paid for. The quality requirements of the materials are specified in Section 3.4 Materials.

2.4.2 Excavation Extent

Excess excavation performed by the Contractor for any purpose or reason other than that ordered in writing by the Engineer, shall be at the expense of contractor. All excavation for structures shall be carried to foundation satisfactory to the Engineer regardless of whether the elevation thereof is higher or lower than the elevation shown on the drawings. All necessary precautions shall be taken to preserve the material below and beyond the lines of all excavation in sound undisturbed condition. All over-excavation required by the Engineer to be backfilled shall be backfilled by the Contractor in accordance with instructions of the Engineer; over-excavation in rock shall be backfilled with concrete or as directed by the Engineer; if over-excavation is unauthorized it shall be backfilled at the Contractor's expense. Except where the use of other materials is specifically approved by the Engineer, unauthorized excessive excavation in rock and in earth where side forms are not used shall be Backfilled with concrete at the Contractor's expense. Materials for use in the work shall be carefully excavated to produce the material in form suitable for the work; additional measures such as secondary blasting, mixing, blending and sieving shall be used, if necessary, to make the excavated material suitable for the required use. Excavations through overburden into rock shall be performed in a manner to result in separation of the rock from the overburden so that the maximum practicable amount of suitable embankment and fill material will be produced.

2.4.3 Excavation Tolerances

Excavation shall be performed within the tolerances for excavation limits indicated on the Drawings. Where no tolerance is indicated, excavation shall be performed to tolerance established by the Engineer as acceptable for the design and type of work involved. In cases where the governing criteria permit, the Engineer may relax the tolerance to facilitate construction.

2.4.4 Excavation Line to Suit Field Condition

The character and desired dimensions of the proposed excavations are in general indicated on the Drawings. The Engineer, however, shall have the right to:

- (i) Vary the depth, width, and length of the excavations and to increase or decrease the slopes including berms of the excavations; and
- (ii) Require the use of berms of dimension as instructed in permanent slopes where none are shown on the Drawings, if conditions require or permit such modifications for the purpose of obtaining more stable or economical slopes and/or foundations. The Engineer shall have the right to vary the excavation lines after excavation has been commenced.

2.4.5 Support of Excavations

During the excavation work, the Contractor shall be responsible for providing stable interim excavation slopes and for the proper support of excavations (regardless of the method of support specified by the Engineer) is necessary to accomplish the final construction shown on the Drawings.

2.4.6 Dewatering of Foundations

Contractor shall maintain all foundation and other permanent work areas free of water as approved by the Engineer. The Contractor shall provide, install, operate and maintain approved Dewatering systems (including sufficient standby equipment) to dewater and keep dry all areas of construction during construction operations and as required keeping excavated foundation and side slopes stable. All fill material shall be placed in the dry place. The Contractor shall employ pumping methods in such a way as to prevent loss of fines from or other damage to foundations, maintain the stability of the excavated slopes permit construction operations, as required to be performed in the dry. The Contractor shall also install measurement and recording devices approved by the Engineer, for accurately measuring the quantities and rate of water pumped.

No separate payment will be made for dewatering of foundations. The cost shall be included in the Contract lump sum price for the care of water during construction (Section 1).

2.5 FOUNDATION PREPARATION

2.5.1 Clearing and Stripping for Embankment Foundations

All areas against which fill has to be placed directly shall be cleared of all vegetation as described in this Section. Clearing within the fill areas shall consist of the complete removal above ground of trees and all bushes, shrubs, weeds and vegetation and all debris and objectionable material. Cleared material shall be disposed of by the contractor by burning in open area the combustible materials and removal of the incombustible materials from the site of work in a waste area designated by the Engineer. In addition, the areas to receive embankments shall be stripped of all organic soils, loose rocks and loose talus as directed by the Engineer. The haulage involved in the operation is included in the BOQ.

2.5.2 Preparation of Foundations

- (a) Some of the foundation materials may deteriorate on exposure and get disturbed and remolded by construction traffic. The Contractor shall carry out his operations in such a manner that the risk of disturbance, deterioration and remolding is reduced to a minimum.
- (b) Rock out-crops and knobs shall be reduced to required slopes and the excavation for embankment base done accordingly to bring it to proper level and grade, as directed by the Engineer. The haulage for stock pile and disposal of un-useable material downstream of dam body is included in the BOQ.

2.5.3 Excavation for Core Trench

Beneath the foundation of the dam within limits as shown on the Drawings necessary earth materials shall be excavated, bed rock surfaces prepared and impervious fill material placed as required for the control of under - seepage. Excavation shall be carried to the specified depth in the river bed and to reasonably sound strata at the abutments. Contractor shall be responsible for the maintenance of stable slopes during the excavation and backfill of the core trench. The slopes shown on the Drawing are indicative and may be varied or supplemented with berms, if required, subject to the approval of the Engineer. The suitable material excavated from the core trench will be allowed to be placed in the main embankment or in cofferdam as directed by the Engineer and the Contractor may stockpile such suitable materials for further use. The payment for placement of suitable material will be made separately according to other materials in the dam. The unsuitable material will be disposed of in the designated spoil area, and no additional payment will be made for the stockpiling and disposal work. The portion of the excavation for the core trench below water table shall be dewatered subject to the requirements of Section 2.4.6. During the placing and compacting of the fill material in the core trench the water level at every point in the core trench shall be maintained below the bottom of trench. The haulage for stock pile and usable material is included in the BOQ,

2.5.4 Surface Dental Treatment

Exposed rock surface within the rock-cutoff contact areas shall be cleaned by brooming and compressed air injection. Surface treatment shall be performed if necessary, to ensure that no open or loosely filled fissures, joints or bedding planes are present which might permit concentrations along the rock-cutoff contact areas. Surface treatment shall consist of coating with asphalt emulsion or slush grouting, as directed by the Engineer. Slush grouting shall consist of treatment of cracks and fissures with a 1:6 cement water mixture under light pressure, as and where directed by the Engineer.

Unsatisfactory material in pockets, seams and fissures shall be removed, if so ordered by the Engineer. Fissures, seams and shear zones exposed in the cleaning process shall be immediately filled with dental concrete, as directed by the Engineer. Exposed surface of final grade excavation in rock cutoff contact area which cannot be immediately covered with impervious fill shall be coated with asphalt emulsion in order to prevent to atmosphere.

2.5.5 Excavation for Trenches

Unless otherwise directed or permitted by the Engineer not more than 10 m of any trench in advance of the end of the pipeline already laid shall be opened at any time. Trenches shall be excavated to the dimensions and depths shown on the Drawings or ordered by the Engineer or in such a position or to such dimensions and depths as shall allow for the proper construction of the relevant structure of proper execution of the relevant operation. Pipe trenches shall be excavated to give a clear width of 1/2 diameter of pipe with a minimum of 150 mm, on either side of the pipe. Additional excavation shall be carried out to give ample space for making joints and, where necessary, for concrete bedding or surround.

The banks of the pipe trench shall be as nearly vertical as practicable. Bell holes and depressions for joints shall be dug after the trench bottom has been prepared. The pipe, except for joints, shall rest on the prepared bottom for its full length. Bell holes and depressions shall be only of such length, depth, and width as required for properly making the particular type of joints. Stones above 15 cm size shall be removed to avoid point bearing. Whenever wet or otherwise unstable material that is incapable of properly supporting the pipe as determined by the Engineer is encountered in the bottom of the trench, such material shall be removed to the depth required and the trench backfilled to the proper grade with coarse sand, or other suitable approved granular material, such replacement of unsuitable material will be paid for at the contract unit price for that item of work.

Where the Contractor has excavated to depths in excess of the requirements, due to his negligence or from causes within his control, he shall refill and compact at his own expense the excess excavation with suitable material up to corrected level, as approved by the Engineer.

Excavation of appurtenances shall be sufficient to leave at least 300 mm but more

than 600 mm between the outer surface and the embankment or timber that may be used to hold and protect the banks. Any over-depth excavation below such appurtenances that has not been directed by the Engineer, will be considered unauthorized and shall be refilled with compacted sand, gravel or concrete, as directed by the Engineer and at no additional cost to the Employer.

2.5.6 Excavation for Canals / Channels

The work to be done under Excavation for Channels consists of the construction of canals as shown on the Drawings or as designated by the Engineer. All excavations and embankments shall be made to lines and shown on the Drawings or established by the Engineer. Where practicable, the finishing operations of the channel sections shall be performed by the Contractor simultaneously with the channel excavation. During the progress of the work, it may be found necessary or desirable by the Engineer to vary the slopes or the dimensions of the excavations for channels and embankments from those shown on the Drawings or specified herein, and the Contractor shall perform the work to the revised and changed slopes and dimensions. All necessary precautions shall be taken to preserve the material below and beyond lines of nil excavation in the soundest possible condition. Runways for equipment shall not be cut into channels banks.

Excavated materials shall be disposed off in required embankments, backfill or in spoil banks, or shall be placed in approved waste areas or in other locations as directed by the Engineer. Where shown on the Drawings or directed by the Engineer, approved excavated materials shall be placed in compacted embankments along the channel. The approved materials shall be placed in approximately horizontal layers not more than 6 inch thick after being well compacted. Prior to and during placement operations, the material shall have the proper moisture content for compaction as determined by the Engineer. If the moisture content is less than that required for compaction, it shall be supplemented by sprinkling and reworking the material during placement. If the moisture content is greater than that required for compaction, the material shall be dried by reworking, mixing with dry materials or other approval means. Each layer of the embankment shall be compacted by properly routing the travel of the mechanical excavation, hauling and placing equipment over the filling during construction of the compacted embankment.

The Contractor shall not interrupt nor interfere with the natural flows in irrigation and drainage channels for any reason or purpose without the written approval of the Engineer. Should temporary works such as diversion channels and structures be required, the Contractor shall construct, maintain and remove when no longer required all such temporary works. Any damage to temporary and permanent works or the property of others due to improper operation or failure of the works constructed for maintaining flow in irrigation and drainage channels shall be corrected by the Contractor at his own expense.

Measurement for payment for Excavation for Channels will include all excavation

within the channel prism. The channel prism is defined as the volume bonded by the designated bed level of channel, the specified side slopes of the channel projected to the natural surface level, and the natural surface level, all as shown on the Drawings for any particular reach of the channel.

2.5.7 Excavation for Structures

All earth excavation under this contract, which is not included under the classification "Earth excavation in Trenches and cut off trench" shall be classified and paid for as earth excavation for structures.

The Contractor shall provide adequate timbering or shoring for excavations. Should the sides and ends of any excavations give way the contractor shall, at no extra cost, remove all disturbed ground. Any excavation carried out side the limits shown on Drawings and specified herein as the payment limits, shall not be treated as excavated and shall not be paid for.

When foundation level is reached, the Engineer's representative will inspect the exposed ground and give directions as to what further excavation, if any, he considers necessary. The excavation should be done in such a manner as to ensure that the work rests on a solid and perfectly clean foundation. If the Contractor allows any portion of such foundations to deteriorate due to exposure he shall make good the foundation to the satisfaction of the Engineer without extra cost.

Except where otherwise specified in the Special Provision, excavation and backfill for culvert and drainage pipes, except granular backfill to under drains, will not be paid for separately but shall be considered as a subsidiary obligation of the Contractor covered under the contract price for the various classes of culvert pipe as provided.

2.6 PRECAUTIONARY AND REMEDIAL MEASURES

2.6.1 Protection of existing Facilities and Structures

The Contractor shall take every necessary precaution not to endanger the safety, occupation or operation of any property, structures, installations or services in the vicinity of his operations and shall observe any restrictions imposed by authority concerned /Engineer to this end. Any such property, structures, installations or services be endangered or damaged as a result of the Contractor's operations, he shall immediately report any such damage to the Engineer's Representative and the authority concerned and shall forthwith undertake remedial measures to the satisfaction of the Engineer or the appropriate authority.

2.6.2 Planking and Strutting

The Contractor shall provide at his own expense, to the satisfaction of the Engineer, all timbering, poling, shoring, strutting and other approved supports to the sides of all excavations, trenches and all other works in such a way as will be sufficient to secure them from falling and to prevent any movement. All responsibilities connected with this part of the work shall rest with the Contractor.

In removing timbering, shoring and strutting and all other supports from excavation

and trenches, special care shall be taken to avoid pressure on fresh concrete or any other work until it is sufficiently safe to resist such pressure.

2.6.3 Removal of Water

The Contractor shall build all drains and do ditching, pumping, well pointing, bailing, and all other work necessary to keep the excavation clear of ground water, sewage and storm water during the progress of the work and until the finished work is safe from injury. All water pumped or drained from the work shall be disposed off in a manner satisfactory to the Engineer and necessary precautions against flooding shall be taken. The procedure for dewatering of subsoil water from excavation for the purpose of construction of Water Supply lines and other structures shall be in accordance with the method given below:

Dewatering of subsoil water from excavations of trenches and excavations for other structures shall be arranged by an adequate process of well pointing, bailing and /or pumping.

Well pointing shall consist of boreholes, provided with necessary strainers, blind pipes and pumping machinery and these shall be of suitable size and depth and shall be located on both sides of the trench and along the periphery of water level to a sufficient depth to keep the excavations clear of subsoil water during the process of construction.

As a part of the work, and at no extra cost, the Contractor shall provide all strainer pipes and other requisite material, and boring tools and plant, etc. for the well pointing and shall also provide pumping equipment as well as operating personnel, power, etc. Dewatering of subsoil water by well pointing, bailing and/ or pumping shall be continuous process round the clock during the progress of the work and until the finished work is safe, from injury to the complete satisfaction of the Engineer's representative and any interruption in continuous pumping and causing injury to the works done or under construction shall require the Contractor to repair or rebuild the works to the entire satisfaction of the Engineer's representative at no extra cost.

2.6.4 Maintenance of Excavation

All excavation shall be properly maintained while open and exposed. Sufficient suitable barricades, warning lights, flood lights, signs, and similar Items shall be provided by the Contractor, The Contractor shall be responsible for any damage due to his negligence.

No separate payment will be made for the removal of water. The cost thereof shall be included in the contract lump sum price for the care and handling of water during construction (**Section 1**).

2.6.5 Surplus and Unsuitable Materials

All surplus and unsuitable materials shall be removed and disposed of at locations approved by the Engineer. The disposal of aforesaid materials shall not interfere with other works and shall not damage or spoil other material. When it is necessary to haul earth or rock material over street or pavement, the Contractor shall prevent such material from falling on the street or pavement. No separate payment shall be made for removal and disposal of unsuitable or surplus materials.

2.6.6 Cutting Pavement

In cutting or breaking road surfacing, the Contractor shall not use equipment which will damage the adjacent pavement. Existing paved surfaces shall be cut back beyond the edge of trenches to form neat square cuts. The road ballast, brick pavement, and other materials shall be placed on one side and shall be preserved for re-installment when the trench is filled. Wherever necessary or required for the convenience of the public, the contractor shall provide suitable temporary bridges which shall be maintained in service until backfilling has been completed. The contractor shall keep the road crossings manned 24 hours per day. During night time, enough red lights shall be provided to warn the traffic. If detour is necessary, the Contractor shall make proper for the traffic and shall install signs 1 m x 1.2 m in size indicating the detour.

2.7 ROCK EXCAVATION

2.7.1 Rock Excavation for Foundations of Structures

(a) General

Hard Rock shall be excavated by systematic and such approved methods of drilling and blasting which will prevent damage to foundation/ barring and wedging, by ripping or directly by excavating equipment. Precautions shall be taken to preserve the material outside the lines of excavation in an undisturbed condition. Refilling of over excavation beyond lines and grades shown on Drawings shall be done with concrete or other materials approved by the Engineer at the Contractor's expense. The Contractor shall clean rock slope benches and shall maintain an inspection system in regard to hard rock slopes as necessary to provide safe working conditions. Requirements regarding the use of explosives are specified in sub-clause SP-14 Storage and Use of Explosives.

(b) Drilling and Blasting

Wherever blasting is approved by the Engineer, it will be carried out in the foundation area by methods like Line Drilling/ Pre Splitting or Cushion Blasting. The depth and spacing of holes for blasting with such methods during the work shall be determined by the Contractor and will be modified at the direction of the Engineer, based on observation of the manner in which the rock breaks as blasting operations progress and additional

testing as shown to be necessary. Blasting patterns shall be varied as required to produce the gradations required for the material to be placed in the permanent work. Whenever further blasting may injure the rock upon or against which concrete or fill is to be placed/ the use of explosives shall be discontinued and excavation shall be completed by wedging, barring and channeling or other suitable methods. Approval by the Engineer of the method of blasting shall not relieve the Contractor of his sole responsibility for the adequacy and safety of the blasting.

2.7.2 Dental and other below Grade Excavation

Zones of unsatisfactory material below the foundation levels which will require excavation/ may be encountered. All such material/ regardless of character, shall be removed and disposed of as directed by the Engineer. Dental excavation/ to be paid for as Day work/ shall consist of the removal of earth such as talus or alluvium or unsound rock such as soft/ friable or highly weathered rock (and sound rock incidental to such removals) from below the foundation or other base excavation lines directed by the Engineer for structures and for impervious earth-rock contacts/ and from locations such as joints and pockets and between rock beds where the use of power excavation equipment is not practicable. Dental excavation to be paid for as Day work shall not include removal of materials below the aforementioned excavation lines where in the opinion of the Engineer, a removal operation similar to that used for any portion of the excavation above such lines could be used. Dental excavation to be paid for as Day work shall not include removal of materials by pressure washing and shall not include excavation which is classified by the Engineer or paid for under another Contract Item. Excavated areas covered in this Sub-section shall be cleaned as specified and provided with dental treatment as provided in sub-section 2.5.4

2.7.3 Preparation of Contact Surface between Rock and Concrete

Exposed rock surface within the foundation against which concrete is to be placed shall be cleaned and broomed and the surface undulations shall be covered and filled with a layer of blinding concrete as directed by the Engineer. The blinding concrete shall be provided according to Specifications in **Section 5** for Concrete.

2.8 ROCK QUARRIES

2.8.1 General

The rock for riprap material and stone pitching shall be obtained from the rock borrow area as indentified during the investigations or from other rock quarries near the dam site as directed by the Engineer. The Contractor shall exploit, develop and maintain the approved rock quarries and pits in a suitable condition for the extraction and removal of the required materials in a manner satisfactory to the Engineer, and so as to obtain at all times the greatest practicable yield of suitable material in the deposit. The fact that the Employer has approved the Site and location from which material for riprap and stone pitching may be obtained shall not be considered as

constituting the approval for use of all material extracted from the quarries and the Contractor shall be responsible for the specified quality and grading of such produced material. For quality and gradation of riprap material the Section 3.4 Materials shall be applicable.

The quantity of rock from rock borrow area is gross estimated quantity and there is no guarantee that this quarry will yield such quantities of suitable material. If the Contractor proposes to use any additional rock quarry, he shall do so with the written approval of the Engineer.

2.8.2 Blasting and Excavations

The methods of excavating, quarrying and size separation shall be subject to the approval of the Engineer. Selected areas in the rock source will be designated for the riprap material. The gradation of riprap is specified in Section 3.4.2 and Contractor shall plan his blasting and quarrying work in a manner to produce material according to the required gradation.

2.8.3 Measurement and Payment for Quarried Material

The processed material from the rock quarries shall be placed in the dam or spillway or in other areas as directed by the Engineer as per Section 3.7 to 3.10 which Items shall include the entire cost of processing, separating, grading, handling, transportation, stockpiling and placement of this material. No separate payment shall be made for the excavation of the material under this Section.

2.9 EARTH BORROW AREAS

2.9.1 General

Borrow areas for earth material in the permanent works shall be the borrow areas shown on the Drawings or as specified by the engineer, additional borrow areas selected by the Contractor subject to approval of the Engineer. Investigations in the borrow areas shown on the Drawings have shown that material suitable for use in the permanent work is found in these borrow areas. If the Contractor proposes to use borrow areas other than those investigated and suggested by the engineer, he shall make other investigations at his expense and furnish such evidence for approval of the Engineer, as will indicate that the borrow area can be used as a source of materials suitable for the embankments.

2.9.2 Operation of Borrow Areas

The Contractor shall perform all necessary clearing, stripping, selective excavation to necessary depth and extent, in the dry or below ground water, draining of borrow areas, pre-wetting of material in the borrow areas, dressing of borrow area during and after completion and disposition of materials to obtain and make the material suitable for use in the work. Excavation and transportation may be performed by any approved method and by the use of excavating and transporting equipment suited to accomplish the intended purpose in the work. The Contractor shall determine the conditions of the materials in each borrow area and provide proper

means of handling the materials. Excavation in the borrow areas shall be accomplished to provide proper drainage at all times and to result in the efficient recovery of the maximum amount of suitable materials from the area. Upon completion of the borrow operations the borrow areas outside the limits of the reservoir shall be left reasonably smooth, evenly dressed, and shaped to drain. The contractor may use borrow material in the temporary works, such as cofferdam haul and access roads. However, no measurement for payment will be made of such materials unless such materials are reused, as approved, under an Item in the Bill of Quantities for which measurement and payment of such materials is provided.

2.10 DISPOSITION OF MATERIALS

2.10.1 General

The disposition of all excavated materials including top soil in borrow areas and excess and over break excavation, shall be in accordance with the requirements of the Drawings and Specifications and as approved by the Engineer. Such approval shall supersede the indicated usage of any particular excavation source shown on the Drawings. The Contractor shall be permitted to use all suitable materials from required excavation in the work shown on the Drawings. Suitable materials from borrow areas and quarries shall be used in the works shown on the Drawings; materials from borrow areas and quarries that are designated by the Engineer as unsuitable shall be neatly disposed of in approved locations at no expense to the Employer.

The Contractor shall be responsible for making and maintaining all haul roads required for transport of the materials from the Borrow Areas and Quarries to their required destinations. No separate payment will be due to the Contractor for the haul roads and all costs related to this Item shall be included in the unit prices of the materials as provided in the Bill of Quantities.

2.10.2 Disposition of Suitable Material from Foundation Spillway.

All suitable material excavated from foundations of Dam, Spillway and other excavations, consisting of Rock, Earth as determined by the Engineer may be stockpiled by the Contractor in the designated stockpile areas in an approved manner. The Contractor will be permitted to re-handle and use the suitable material from the stockpiles in the suitable locations for the construction of fill. No extra payment will be made to the Contractor for stockpiling and all payments related to this Item will be covered by the Item related to Excavation.

2.10.3 Disposal at Spoil

Unsuitable materials from required excavations shall be disposed of in the spoil areas selected by the Contractor subject to approval of the Engineer. Spoil areas shall be left in satisfactory conditions, smoothly dressed and shaped to drain. No additional payment will be made to the Contractor for this work; all payments will be covered by the related Item for Excavation.

2.10.4 Boulders

Boulders shall be disposed of as follows or as otherwise approved by the Engineer. Boulders encountered in the borrow areas shall be disposed of in the borrow excavation. Boulders encountered in other open cut excavations shall be hauled to

the directed areas; breaking if necessary shall be performed to make the material suitable for use in the works.

2.11 MEASUREMENT AND PAYMENT

2.11.1 General

The measurement for all excavations shall always be made for the final designed lines of the Structure unless specifically allowed otherwise by the Engineer. The Contractor shall himself make allowance for extra earthwork, spaces or areas required for working. Similarly, no separate measuring shall be made for supports, shoring, planking, strutting and dewatering which the Contractor may require to complete the job.

The measurement for excavations in borrow areas shall be made for the final acceptably placed fill without any allowance for bulking or otherwise. The Contractor shall be deemed to have made all such allowances in the unit rates quoted by him.

2.11.2 Clearing, Stripping and Grading of Foundations for Embankment Dam and its Abutments.

Measurement for clearing, stripping and grading of foundations of dam will be made in square meter projected vertically to a horizontal plane of the foundation area acceptably cleared, stripped and graded as per Section 2.5. No separate payment will be made for bushes and trees and their removal will be deemed to be included in the measurement for overburden and other unsuitable materials.

Payment will be made for the number of square meter as measured above for clearing, stripping and grading of foundations for dam and shall constitute full compensation for clearing, stripping and grading of all material related to this Item including disposal of the stripped material in the spoil areas as directed by the Engineer.

2.11.3 Excavation for Core Trench in Earth

Measurement will be made of the number of cubic meter of Earth as defined in Section 2.3 Classification in original position acceptably removed from within the lines and grades shown on the Drawing or directed by the Engineer for providing cutoff below the dam in core trench, abutments and toe drain.

Payment will be made for the number of cubic meter measured as provided above at the contract unit price of Excavation for core trench and shall constitute full compensation for excavating the Earth from foundations including disposal in the stockpiles or spoil area as directed by the Engineer.

2.11.4 Excavation for Core Trench in Rock

Measurement will be made for the number of cubic meter of Rock as defined in Section 2.3 Classification in original position acceptably excavated from core trench,

abutments and toe dam within the lines and grades shown on the drawing or as directed by the Engineer.

Payment will be made for number of cubic meter measured as provided above at the Contract unit price for Excavation of Rock in the core trench and shall constitute full compensation for excavating the rock including breaking up rock, re-handling/ its disposal in the stockpiles or spoil area or as otherwise directed by the Engineer.

2.11.5 Excavation for Trenches

Measurement will be made of the number of cubic meter of Earth acceptably removed from within the lines and grades shown on the Drawings or as directed by the Engineer.

Payment will be made for the number of cubic meters measured as provided above at the contract unit price of Excavation for trenches and shall constitute full compensation for excavating the Earth from trenches including disposal in the stockpiles or spoil area as directed by the Engineer.

2.11.6 Excavation for Canals/Channels

Measurement for payment for Excavation for Channels will be made of the material in excavation only, regardless of the method of excavation or type of material excavated, and only of material excavated at the direction of the Engineer. Measurement for payment for Excavation for Channels will include all excavation within channel prism. No measurement for payment will be made of over-excavation of the Channel prism, except where done at the direction of the Engineer.

Payment for Excavation for Channels will be made at the contract unit-price per cubic meter for Excavation for Channels. The amount shall be full payment for the work specified herein as Excavation for Channels, including stripping and removal of debris from areas not designated to be paid for separately under Clearing.

2.11.7 Surface-Dental Treatment of Foundation-Dental Concrete

The measurement and payment for Dental Concrete shall be made under Section 5, "Plain and Reinforced Concrete.

2.11.8 Surface – Dental Treatment of foundation Dental Concrete

Measurement will be made for the number of liters of Asphalt emulsion sprayed in the acceptable manner to cover the prepared foundation as specified in Section 2.5.4

Payment will be made for the number of liters of Asphalt emulsion measured above for the Contract unit Item for Asphalt Emulsion Spray Coat and shall constitute full compensation for all the material and labour supplied for coating the foundation by spraying the asphalt emulsion over it and all other work related to the Item.

2.11.9 Surface-Dental Treatment of Foundation for Core Trench-Rock-Slush Grouting.

Measurement will be made of the number of square meter of area treated with slush

grouting to cover the prepared foundation in the acceptable manner as specified in Section 2.5.4.

Payment will be made for the number of square meters of foundation area treated with slush grouting as measured above at contract unit rate for slush grouting and shall constitute full compensation for all the material and labour supplied for slush grouting of the foundation area and all other work related to the Item.

2.11.10 Dental and other Below Grade Excavation and Backfilling

Dental and other below grade excavation and backfilling ordered by the Engineer to be carried out as Day work shall be paid for at Day work rates entered against the appropriate Items in Day work Schedule, Appendix-D to Tender, Day work Rates for Labour, Plant and Materials.

2.11.11 Excavation of Earth and Rock in the Foundation of Structures

Measurement will be made for the number of cubic meter of Earth and Rock respectively as defined in Section 2.3 Classification, in original position acceptably excavated from the foundation of structures, within the lines and grades shown on the drawing or as directed by the Engineer.

Payment shall be made for number of cubic meter measured as provided above at the Contract unit price for Excavation of Earth and Rock respectively from the foundation of Structures and shall constitute full compensation for excavating the soil or rock including breaking up re-handling its disposal in the stockpiles or spoil area as directed by the Engineer.

2.11.12 Excavation for Disposal Drain in Earth

Measurement will be made of the number of cubic meter of Earth, in original position acceptably removed from within the lines and grades shown on the Drawings or as directed by the Engineer for the disposal drain.

Payment will be made for the number of cubic meter measured as provided above at the contract unit price of Excavation for Disposal Drain and shall constitute full compensation for excavating the Earth from foundations including disposal in the stockpiles or spoil area as directed by the Engineer.

2.11.13 Provide and install PVC Pipe in Water Measuring Structures

Measurement will be made for the number of linear meters of specified diameter of PVC Pipe acceptably installed in the Water measuring structures of best quality as approved by the Engineer.

Payment will be made for the number of linear meter acceptably measured at the contract unit price for providing and installing the PVC and shall constitute full compensation for all the related works in accordance with the drawings or as directed by the Engineer.

SECTION – 3

CONSTRUCTION OF EARTHFILL

3.1 SCOPE

The work covered by this Section consists of the construction of the Embankment Dam, earthfill and stone pitching for Spillway, earthfill for irrigation system, backfill for irrigation conduit and structures and other miscellaneous fills including the preparation of the foundation.

3.2 DEFINITIONS

The term "fill" as used in section 3 of these Specifications is defined as the earth fill portion of the dam including all other fills, riprap, filters and drain materials for the dam and as used in connection with other works. The terms dam and embankment used to devote all earthworks.

"Zone": that part of an embankment or fill, the material for which has specified characteristics such as particle size, moisture content, density and method of placing. Only that zone will be applicable which is mentioned in the drawings and BOQ of the project.

3.3 GENERAL PROVISIONS

3.3.1 Reference Standards

The numbers and subjects of reference standards are listed below:

Standard	Subject
USBR	Earth Manual, Second Edition
BS 1377:1967	Methods of testing soils for civil engineering purposes
ASTM C535	Test for resistance to abrasion for large size coarse aggregate by use of the Los Angeles machine
ASTM C88	Test for soundness of aggregates by use of Sodium Sulphate or Magnesium Sulphate

3.3.2 Submissions by the Contractor

Submission which the Contractor is required to make in relation to embankment other fills include the following:

(a) Drawings:

Contractor's record drawings of the agreed foundation level survey prior to the placement of fill in those areas.

Contractor's record drawings of all agreed level surveys taken for the

purpose of measurement of quantities of fill.

Survey records as specified above shall be submitted to the engineer within 7 days of the completion of the survey work recorded on them.

(b) Test Results:

Laboratory tests and field tests results on agreed format.

(c) Samples:

Materials proposed for use as fill, where specifically required by the Engineer.

3.3.3 Equipment and Methods

Before proceeding with any of the work specified in this section, the Contractor shall furnish the construction sequence and material utilization scheme he proposes to use in fill construction, integrated with requirements of the approved construction schedule, to the Engineer as further information for approval under Clause 14 of the Conditions of the Contract, The Contractor's submission will include the following details:

Proposed method of placing and compacting fill including a schedule of plant and equipment to be used.

Programme for quality control of earthworks.

Proposed sources of all embankment and fill materials including riprap and method of selective excavation and processing

Proposed programme of embankment construction

3.3.4 Test Fills for Embankment

Test fill of 100ft minimum length will be constructed for embankment zones as directed by Engineer. The minimum compacted width shall be at least three rollers widths and for two specified fill thicknesses. No separate payment will be made for these test fills, and if approved, will form part of the permanent works.

3.3.5 Lines and Grades

Fills shall be constructed to the lines, grades, and cross-sections indicated on the Drawings unless otherwise directed by the Engineer. Materials conforming to the requirements specified in Section 3.4 Materials, shall be placed and compacted within the indicated zone limits. The Engineer reserves the right to increase or decrease the foundation widths, the embankment slopes or the zone limits or to make such other changes in the embankment sections as may be deemed

necessary to produce safe structures, or for efficient utilization of materials from required excavations. Settlements of foundation and dam for the post construction period will be provided for by increasing the height of the sections. Required height increases will be determined and specified by the Engineer from settlement observations made as the work progresses.

3.3.6 Backfilling of Excess Excavation

Unless indicated otherwise on the Drawings or allowed in accordance with the written permission issued by the Engineer, Excess Excavation shall be backfilled.

The backfill shall comprise the material comprising the structure on fill material to be placed within the measured excavation, to the same standard as specified for that structure or fill.

Any additional excavation required to enable the backfill to be placed as specified shall also count as Excess Excavation. No additional payment will be made for backfill of Excess Excavation.

3.3.7 Placing of Fill on a Formation

Before the placing of any fill on a Formation all shattered loose and weathered material shall be removed from the excavation so as to ensure that the work rests on a sound and clean foundation or, where appropriate, abuts against undisturbed ground. The methods of cleaning the foundation for the impervious core of embankment shall include the use of compressed air jets where necessary, and the Engineer will inspect and record the geology of these parts of the formation before approving them.

No additional payment will be made for cleaning of the foundation or undisturbed ground as specified above.

3.3.8 Conduct of Work

a) Maintenance, Protection and Tests

The contractor shall maintain and protect the Dam in a satisfactory condition at all times until final completion of all work under the Contract including period of maintenance in accordance with the Clause 9 of the Conditions of Contract. Any approved fill material which is diverted from its use in construction of the dam, or rendered unsuitable after being placed in the dam before final acceptance of the work, shall be replaced by the Contractor in a satisfactory manner and no additional payment will be made thereof. The Engineer will establish a programme of testing of

in-place fill to ensure that the work is being performed in conformity with the requirements of these Specifications. The Engineer will also perform tests on material at their source and during their processing and handling as necessary for quality control and the Contractor shall adjust his methods as Specification requirements. Tests of material and embankment construction will be made at regular intervals and Engineer will notify Contractor of any deficiencies in materials and/or construction when results of tests are known. Deficiencies shall be remedied by such measures as the Engineer may direct. Remedies shall include the complete removal of portions of the fill if so directed by the Engineer. The contractor shall dispose of any unsuitable materials and refill the excavated area with suitable material as directed, at no cost to the Employer. The Contractor may be required to remove/ at his own expense, any fill placed outside of the prescribed slope lines where such placement is not authorized by the Engineer.

(b) Haul Road

Haul roads shall be located and constructed as approved by the Engineer. They shall be designed to maintain the intended traffic safely, without endangering dam stability during the construction period and shall be constructed in a manner to preclude contamination or alteration of materials forming the dam section. All haul roads located on dam slopes shall be removed at the completion of dam construction. Roads on abutments, which would be unstable during reservoir operations shall be removed at the completion of the dam construction or stabilised to the satisfaction of the Engineer. Haul or construction roads shall not be measured for payments.

(c) Stockpiles

Whenever the Contractor for his own convenience excavates and stockpiles fill material for subsequent usage in the fill, no additional payment shall be made for such stockpiling nor for the reloading and hauling of this material to its final position in the embankment except where specifically provided in the Specifications and Bill of Quantities.

Any stockpile shall contain material suitable for use in one fill Zone only, unless otherwise authorized in writing by the Engineer, and the Contractor shall advise the Engineer of the intended use of the material contained in all such stockpiles.

3.4 MATERIALS

3.4.1 General

Fill materials shall be obtained primarily from the designated borrow areas. The Contractor may use the suitable materials for the fill from additional sources on any borrow areas investigated by him, with the approval of Engineer who will satisfy himself that the material conform to the specifications. Providing the material of the zoned embankment is mentioned in the drawings and the material with haulage is however, included in the B.O.Q. Material containing bush, roots, sod, organic material or other material not considered suitable shall be cleaned of such materials or shall be wasted in areas away from the work site, as approved by the Engineer. All materials shall not contain any clods and Jumps which cannot be broken up during compaction and shall conform to the requirements of the Specifications, their dispositions in the dam shall be as directed by the Engineer.

3.4.2 Riprap

Limestone materials for riprap slope protection of embankment, flexible riprap apron and stone pitching at other designated areas, shall be hard, angular, sound, durable, free from cracks, seams or other defects which would lend to increase unduly its deterioration from natural causes. Material for riprap shall be obtained from the designated areas and shall conform to the grading limits shown on the drawings.

Abrasion after 1000 revolution in a Los Angeles' machine in accordance with ASTM C535 shall not exceed a loss in weight of more than 40 %. The soundness shall be measured in Sodium Sulphate solution in accordance with ASTM CSS. The loss in weight after 5 cycles shall not exceed 5%.

3.4.3 Filter under upstream Riprap and Downstream slope protection

Material (Cobbles and gravel) for the filter under upstream riprap and downstream slope protection shall comprise hard, durable non-cohesive particles.

The material can be obtained from the overburden or quarried rock of the same quality as riprap but conforming to the specified gradation limits.

3.4.4 Impervious Core

Material for compacted impervious core shall be the clayey-silt or silty clay or other suitable material available in approved borrow areas or other sites and shall conform to the grading limits shown on the drawings.

3.4.5 Silty Sandy Gravel Fill

Material for compacted silty-sandy gravel fills, in both upstream and downstream shells, shall be obtained from the nullah bed and other approved borrow areas. The material shall be well graded shall conform to the grading limits shown on the drawings.

Excavated Sandy material from the spillway will also be used as downstream shell fill after approval of the Engineer. No screening or processing of the sandstone for grading control shall be desired except for the exclusion of lumps, bigger than the thickness of the compacted layers which can not be broken down by the compaction equipment.

3.4.6 Sandy Gravel Fill

Material for compacted sandy gravel fill as filter under downstream slope protection shall be obtained from the nullah bed at and near the dam site after screening the finer material. The material shall be well graded shall conform to the grading limits shown on the drawings.

3.4.7 Gravel Drainage Blanket

Material for compacted drainage blanket shall be angular, sound and durable gravels. This material shall be cohesion less and well graded, shall conform to the grading limits shown on the drawings.

3.4.8 Sand Filter

Material for compacted sand filter and chimney drain shall be obtained from the approved sources. The material shall be well graded and shall conform to the grading limits shown on the drawings.

3.4.9 Downstream Sandy Gravel Toe

Material for the downstream sandy gravel toe shall conform to the gradation and quality requirements for material as given in Section 3.4.6 above.

3.4.10 Slush Grout

Slush grout for scaling the rock surface of the core foundation after cleaning shall be made if required with clean well-ground sand conforming to ASTM concrete sand with ordinary Portland cement.

The slush grout shall contain between 2 parts and 3 parts of sand to one part of cement as part of cement as approved by the Engineer. Its water content shall be sufficient to produce a mixture, which can be poured to penetrate and fill open joints, fissures and fractures in the rock surface and can be broomed over and into the rock surface to fill minor surface discontinuities and irregularities.

3.5 CONTACT BETWEEN ROCK AND IMPERVIOUS CUTOFF

3.5.1 Rock Cutoff Contact

Requirement for contact between rock and impervious cutoff area are specified in Subsection 2.5.3. Excavation for Dam Core trench and Subsection 3.4.10 Slush grout.

3.6 PREPARATION OF DAM FOUNDATION FOR FILL GENERAL

Requirement for preparation of dam foundation are specified in Section 2.5. Foundation preparation and Subsection 3.3.7 Placing of Fill on a Formation.

Where fill is to be placed on an excavated and trimmed overburden surface, the area designated in writing by the Engineer, the Contractor shall roll the trimmed foundation surface as though it were part of fill, as each layer of fill is compacted.

Where fill is to be placed on the rock, the hollows shall be filled with fill concrete or compacted fill material as directed by the Engineer. Where ordered by the Engineer, the Contractor shall carry out Incidental Excavation and refill with compacted fill material or fill concrete.

After excavation and surface preparation has been completed in a particular area, the Contractor shall take all necessary steps to prevent deterioration of the surface before it is covered by fill. If, notwithstanding these requirements, any deterioration does take place, the Contractor shall carry out such remedial works as the Engineer considers to be reasonably necessary. Where required by the Engineer, the foundation shall be sprayed with water before fill material is placed, and standing or running water will not be allowed.

Where grouting has been carried out prior to fill, all excess grout and debris shall be cleared by the methods such the slush grout cap and underlying grout curtain shall not be damaged.

3.7 PLACEMENT

3.7.1 General

No fill material shall be placed on any part of the foundation until that part has been inspected and approved by the Engineer and agreed levels recorded. Any fill material placed before the foundation has been inspected and approved by the Engineer, shall be removed and the foundation prepared again at no additional cost to the Employer.

Material of the several type and qualities required shall be deposited and distributed within the zone limits shown on the Drawings and to the slopes indicated within the tolerance specified below. The gradation and distribution of materials in the Zones of dam shall be such as to produce in each Zone a reasonably well-graded mass. Fill material shall be handled and placed by such methods as will minimize segregation, in lifts of depths as specified, and in general so that the smaller sizes

of the material within the dam are placed towards the middle and the larger sizes towards the outer surfaces. Where Riprap slope protection is placed on permanently exposed embankment slopes, the placing of fill shall be supplemented by required methods to obtain surfaces within a tolerance of plus 4-inch (10 cm) and minus 2-inch (5 cm) except that the extreme minus or plus tolerance shall not be continuous over an area greater than 200 square meter (200 square meters). For all other Zones not specified above, or elsewhere, material shall be placed as close as practicable to the lines shown on the Drawings or as approved by the Engineer. Bridging in the fill, and all slabs and slabby rock shall be broken down.

If in the opinion of the Engineer the rolled surface on any layer of fill is too dry or smooth to bond properly with the material to be placed thereon, it shall be moistened and worked with a harrow or scarified in an approved manner to sufficient depth to provide a satisfactory bonding surface before the succeeding layer of fill material is placed. If in the opinion of the Engineer the rolled surface of any layer of in-place fill material is too wet for proper placement of the layer to be placed thereon, it shall be removed or scarified or harrowed to reduce the water content to the required amount before the succeeding layer is placed thereon.

The Contractor shall complete each layer of fill fully up to the abutment-contacts and against sloping foundations and ensure that the fill is compacted as specified throughout.

3.7.2 Deterioration of Fill Material

Should the material selected as fill, while acceptable at the time of selection, becomes unacceptable to the Engineer, for any reason, including exposure to weather conditions/ flooding, contamination by other materials or segregation during progress of works, the Contractor shall remove such damaged, softened or segregated material to a spoil tip and replace it with fresh approved material, at no additional cost to the Employer,

3.7.3 Protection of Completed Fill Surface

The Contractor shall be responsible for protecting completed fill surface against erosion. If it starts to rain, the surface of the fill shall be made smooth with a drainage slope to induce runoff from the filled areas and leave no areas that can retain water. Run off from heavy rain shall be controlled to prevent gully erosion of the placed fill. Any gully erosion shall be repaired with material compacted in accordance with these Specifications, and eroded surface shall be restored and graded to ensure a proper bond with new fill placed on them.

3.7.4 Unrestrained Edges of Fill

The unrestrained edges of fill for permanent slopes shall be overbuilt as necessary to allow full compaction to be achieved within the defined limits of the fill. The excess material shall be trimmed and removed to leave a regular compacted surface.

3.7.5 Rate of Placement

Unless other wise indicated or directed by the Engineer the top of each embankment Zone, including the riprap shall be maintained at the approximately the same level throughout each embankment construction stage regardless of the number and types of materials being placed, except; as may be required to prevent mixture of embankment materials. Materials shall be delivered in proper sequence and distributed over the surfaces of the fills at such a rate as will ensure the completion of each embankment Zone and stage thereof within the specified time.

3.7.6 Watering of Fill

During dry weather, whether fill is being placed or not, the surface of the fill shall be sprayed with water to prevent cracking of the surface. If cracking of the surface of fill occur, the Contractor shall remove such cracking material and replace it with fresh fill within the specified range of moisture content.

3.7.7 Riprap Protection Placement

Stone for riprap shall be hand placed on the Dam and elsewhere within the limits indicated for material in such manner as to produce a well graded mass of rock with the minimum practicable percentage of voids and shall be constructed within the specified tolerance to the lines and grades shown on the Drawings or Stacked in the field. A tolerance of plus 4-inch (70 cm) or minus 2-inch (5 cm) from the slope lines and grades shown on the Drawings will be allowed in the finished surface of the riprap, except that either extreme of such tolerance shall not be continuous over an area greater than 200 Square meter (200Sq meters). The larger stones shall be well distributed and the entire mass of stones in their final position shall be roughly graded to conform to the gradation specified in in the drawing. The finished riprap shall be free from objectionable pockets of small stones and clusters of larger stones. Unless otherwise authorized by the Engineer, riprap protection shall be placed in conjunction with the construction of the riprap as may be necessary to prevent mixture of embankment and stone protection materials.

3.7.8 Filter Under Upstream Riprap and Downstream Slope Protection Placement

Cobbles and gravel for filter layer and protective layer shall be hand placed within the limits shown on the Drawings. Riprap Protection, placement and as further directed by the Engineer. Care shall be taken that materials do not get mixed with or material.

3.7.9 Gravel Drainage Blanket Placement

The gravel in drainage blanket shall be placed in the Dam within the limits shown on the Drawings. Care shall be taken that material does not get mixed with other material. The loading from the stockpiles shall be done in such a manner that segregation is minimized. If considered necessary by the Engineer, some mixing or wetting of material before hauling shall be done.

3.7.10 Impervious Core Placement

Impervious core fill shall be placed in the embankment including cut off trench within the limits indicated for fill material. If in the opinion of the Engineer the rolled surface on any layer of fill is too dry or smooth to bond properly with the layer of material to be placed thereon it shall be moistened and worked with a harrow or scarifier in an approved manner to sufficient depth to provide a satisfactory bonding surface before the succeeding layer of fill material is placed. If in the opinion of the Engineer the rolled surface of any layer of in-place fill is too wet for proper placement of the layer to be placed thereon, it shall be removed or scarified or harrowed to reduce the water content to the required amount before the succeeding layer is placed thereon. No fill shall be placed below water. During placement and Compacting of cutoff trench material, the water level at every point in the cut off trench shall be maintained below the foundation of trench till entire cutoff trench has been completely filled and duly compacted.

3.7.11 Sand Filter Placement

The compacted sand filter shall be placed in the dam within the limits shown on the Drawings. The loading from stockpiles shall be done in such a manner that segregation will be minimized. The material shall be made wet at the source and in any stockpiles, and during transportation and placing, to prevent segregation. Care shall be taken that material does not get with other zone materials.

3.7.12 Sandy Gravel Fill Placement

The compacted sandy gravel fill at the filter under D/S stone protection, shall be placed in the dam within the limits shown on the Drawings.

3.7.13 Downstream Rock fill Toe placement

Stone in rock fill toe shall be placed at the random in the dam within the limits shown on Drawings. The finished Zone shall be free from objectionable pockets of small stones and clusters of larger stones.

3.7.14 Silty Sandy Gravel Placement

The compacted silty sandy gravel fill in upstream and downstream shells, shall be placed in the dam within the limits shown on the Drawings.

Individual lumps of sandstone rock Subsection 3.4.5 which cannot be broken down by compaction equipment will be acceptable within the fill Zone of Shell material, provided that their largest dimensions is smaller than the layer thickness, that such lumps are completely surrounded by compacted fill conforming to the specified requirement and that such lumps do not comprise more than 10 % of the fill in any layer.

3.7.15 Stone Apron - Placement

The areas designated for placement of stone apron shall be excavated to the lines and grades shown on the Drawings or as directed by the Engineer to form a trough. The revetment stone shall then be hand placed in the excavated trough in such a manner that open spaces between stone are avoided.

3.7.16 Stone Pitching - Placement

The areas designated for placement of stone pitching shall be excavated to the lines and grades shown on the Drawings or as directed by the Engineer.

Stone and rock spalls used in the stone pitching shall be placed and bedded in such a manner that the completed stone pitching is stable and without tendency to slide. Large open spaces between the stone shall be avoided. Care shall be taken to ensure that all stone is well bedded on its flattest surface. The stone shall be placed so as not to project above the neat lines shown on the Drawings or directed by the Engineer. All interstices in the stone pitching shall be well-filled with rock spalls. The amount of rock spalls used shall not be in excess of that required to fill the voids in the revetment stone.

Cement grouting shall be performed in stone pitching for the Toe Drain which shall consist of filling with 1:4 cement sand mixture as shown on the Drawings or as directed by the Engineer.

3.8 SPREADING

After depositing, the materials shall be spread by approved means in approximately horizontal and uniform layers of fill material, to ensure proper and uniform compaction. Except as otherwise directed by the Engineer as a result of the tests conducted during construction/ the maximum thickness of each compacted fill layer for different Zones shall be as follows:

Shell Material	12-inch (30 cm)
Clay Core Material	6-inch (15 cm)
Coarse Filter	8-inch (20 cm)
Fine Filter Material	8-inch (20 cm)

The riprap and stone protection layer materials shall be placed in accordance with Section 3.7.3 Riprap Protection.

The Contractor shall determine by making test sections, the loose lift thickness required in order to attain the compacted thickness specified herein. Where reduction or increase in lift thickness is ordered by the Engineer, the maximum particle size permitted shall not exceed the compacted lift thickness. During dumping and spreading the Contractor shall provide at all times adequate facilities for removal of all unsuitable and/or oversize material. Unsuitable materials shall be removed from the embankment and disposed of in an approved manner. The entire surface or any section of the embankment under construction shall be maintained in such a condition that construction equipment can travel on any part of the section. Ruts in the surface of any layer shall be filled satisfactorily before compacting.

3.9 MOISTURE CONTROL

3.9.1 General

Where necessary, the Contractor shall adjust the moisture content of fill, either by drying out or adding water, so that it is within the range of moisture content for the fill after the compaction as set out in the Compaction Table included hereto. The water and fill shall be thoroughly mixed to uniform moisture content.

The Contractor shall ensure that water being applied to adjust the moisture content of material in one Zone 6 does not drain off the surface on to another Zone.

3.9.2 Fill Material Zone 1

All processing of Zone 1 (Core) material, to produce rolled fill including the adjustment of moisture content and breaking of lumps, shall be done before the material is hauled to the area where it is to be placed and compacted. So far as practicable, the material shall be delivered and spread in moisture range of 2 % above Standard Proctor optimum to optimum by irrigation or drying within the borrow areas. On the basis of tests conducted during construction, the Engineer reserves the right to make modifications in the required range of moisture for this material. Only such moisture variation as is needed for minor adjustment of moisture changes caused by evaporation during handling and placement or rainfall shall be allowed on the fill. The moisture shall be distributed uniformly throughout each layer prior to compaction. Optimum moisture content shall be determined in the laboratory by the Engineer by making Standard Proctor compaction test. The optimum moisture contents for the materials in borrow area will be furnished by the Contractor to the Engineer at daily intervals or at significant changes of material being placed.

3.9.3 Other Zones

As determined by the Engineer, some addition of water will be required for compaction of materials in other Zones of the dam and to reduce segregation tendencies. The addition of water for this purpose shall be accomplished prior to handling, unless otherwise directed by the Engineer.

3.10 COMPACTION

3.10.1 General

The compaction of fill material placed in the various zones shall be carried out to the requirement set out in the Compaction Table included hereto. The requirements of the Compaction Table apply to each layer of fill after it has been compacted and before it is covered by a subsequent layer of fill. The following definitions shall apply with respect to Compaction Table:

- Moisture content/ shall be the moisture content immediately after compaction,
- Layer thickness, shall be the thickness after compaction.

- Relative compaction (rc) shall be measured as a percentage of the maximum dry density measured by BS 1377:1967, Test 12.
- Relative Density (rd.) of cohesion less soils shall be measured as described in USBR Earth Manual, Second Edition, Appendix E -12.

3.10.2 Equipment

Compaction equipment shall generally consist of vibratory rollers, temping rollers and other approved rollers and shall be used as prescribed in subsequent Sections and as determined and ordered by the Engineer as a result of the tests conducted during construction.

(a) Special Compactors

Compaction of materials in areas where it is impracticable to use a roller or tractor, as provided above, shall be performed by the use of compactors of the heavy-duty power driven type. They shall be capable of producing densities at least equal to those produced by the equipment specified in Sub-Clause (a) hereof. All such equipment will be subject to approval by the Engineer. Compactors, which do not obtain the required density with a reasonable amount of coverage of each layer and at a production rate consistent with the adjacent embankment, shall not be used in the work. Compacted layer thickness by this equipment shall not exceed 4-inch (10 cm).

(b) Sprinkling Equipment

Sprinkling Equipment shall consist of tank trucks, pressure - distributors, or other equipment designed to apply water uniformly and in controlled quantities to variable widths of surface. Tanks trucks shall be equipped with positive shutoff valve so that no leakage will result from the nozzles when equipment is not operating. Leaks shall be repaired immediately and any material rendered too wet because of faulty equipment shall be removed reconditioned and no additional payment will be made therefore.

COMPACTION TABLE

Material	Compacted Layer thickness (inches)	Relative compaction (r.c.) or Relative Density (r.d.)		Moisture content (%) (Related to optimum for relative compaction test as specified)	
		2/3 rds of Test Results to Exceed	All Test Results to Exceed	2/3 rds of Test Results to be	All Test Results to be
Impervious Core	6	r.c = 98%	r.c. = 95%	Between +1 and +3	Greater than 0
		(Standard Proctor)			
Upstream Shell	12	r.c = 98%	r.c. = 95%	Between -2 and +1	Between -3 and +2
		(Standard Proctor)			
Downstream shell	12	r.c = 95%	r.c. = 92%	Between -2 and +1	Between -3 and +2
		(Standard Proctor)			
Filter under upstream slope Riprap Layer	12	r.d = 75%	r.d. = 65%	--	--
Downstream Slope Protection	12	r.d = 75%	r.d. = 65%	--	--
Filter under downstream slope protection	12	r.d = 75%	r.d. = 65%	--	--
Fine Filter	8	r.d = 75%	r.d. = 65%	--	--
Coarse Filter	8	r.d = 75%	r.d. = 65%	--	--

Note:- The embankment zones are applicable which are mentioned in drawings and BOQ of the Project.

- * The relative compaction (r.c.): refer to BS 1377:1967, Test 12.
- * The relative density (r.d.): refer to USBR Earth Manual, Second Edition, Appendix-E 12.
- * A moisture content given in the Table as minus a number (x) is x% below the optimum moisture content (y %): i.e. the moisture content "-x" is (y-x) %. Similarly, the moisture content "+x" is (y+x) %.

3.10.3 Compaction General

After a layer of fill material has been deposited, it shall be scarified, bladed or otherwise treated as necessary to produce a uniform material with respect to moisture' content and grain size distribution, in accordance with Section 3.9 Moisture Control mixing shall be performed to the full depth of the layer if so required. When the moisture content and conditions of the layer is satisfactory the lift shall be compacted. Portions of the fill which are not accessible to the roller shall be placed in lifts consistent with the material size and compacted with power tempers to a degree equal to that obtained on the other portions of the compacted fill by rolling as specified Dumping, spreading, sprinkling and compacting may be performed at the same time at different points along a section of Embankment when there is sufficient area to permit these operations to proceed simultaneously.

Unless other wise approved by the Engineer, the direction of compaction rolling in the embankment shall be parallel to the axis of the embankment.

3.10.4 Subgrade Compaction

The Subgrade below the dam shall be scarified by harrows to a depth of 10 -inch (25 cm), the material shall then be moistened as per clause 3.9.3 and compacted with not less than ten passes of the specified vibratory roller.

3.10.5 Compaction of Fill Material

Except as otherwise determined and ordered by the Engineer fill materials shall be deposited in successive layers of thickness as specified and compacted as follows:

- (a) Each layer of fill material in the impervious Zone 3 and Zone 2, shall be compacted to a dry density not less than 98% Standard Proctor laboratory density.
- (b) In other zones, each layer of material except riprap slope protection shall be compacted to a dry density not less than 75% relative density.
- (c) Compaction of riprap layer will not be required.

3.11 SLIDES

- (a) In the event of slides in any part of the embankment prior to final acceptance of the work, the Contractor shall remove material from the slide area, as directed, and shall rebuild such portion of the embankment. In case it is determined that the slide was caused through the fault of the Contractor, the removal and disposal of material and the rebuilding of the embankment shall be performed without cost to the Employer; other wise this work will be paid for the applicable Contract unit prices for the compacted fill or backfill.

(b) Lightly Compacted Fills

Fills and backfills designated on the Drawings or directed by the Engineer to be lightly compacted shall be such as to produce a dry density not less than 90% Standard Proctor laboratory density for cohesive materials and a dry density of not less than 65% relative density for granular materials. Compaction equipment shall conform to the general requirements of Section 3.10 Compaction.

3.12 MISCELLANEOUS FILLS AND BACKFILLS

3.12.1 General

In addition to the embankment fill for the dam certain miscellaneous fills and backfills will be required for Spillway, irrigation system, irrigation conduit and other structures and near the abutment areas. Material requirements for these backfills shall be specified on the Drawings and the type of material for these fills will be as specified in Section 3.4 Materials or as directed by the Engineer.

3.12.2 Operations Adjacent to Existing Structures

In general, no fill or backfill or other load shall be placed on or against the surface of any concrete structure earlier than is permissible with regard to the protection of the structure. At locations where the safety of structure might be endangered, such operations shall not proceed until the construction has attained sufficient strength to withstand any stresses that might develop incidental to the operations required; provided that no fill or backfill will be placed without the prior approval of the Engineer. If so required the Contractor shall submit details of the methods of placement, spreading and compaction he proposes to use for the protection of structures at such locations for the approval of the Engineer. Within areas where rollers cannot be used, the material shall be compacted by means of power tampers. Drainage openings through walls shall be kept open at all times.

3.12.3 Compaction

Subject to the limitations on compaction of fill and backfill material adjacent to structures and/or drainage features specified in the Subsection 3/12.2. Operations Adjacent to Existing Structures above, compaction of fills and backfills shall conform to the following except if specified as dump fill.

(a) Well Compacted Fill

Fills and backfills designated on the Drawings or directed by the Engineer to be well compacted shall be as such as to produce a dry density of not less than 98% Standard Proctor laboratory density for cohesive materials and a dry density of not less than 75% relative density for granular materials. Compaction equipment and procedures shall conform to the general requirements of Section 3.10 Compaction.

3.13 BACKFILLING OF TRENCHES

3.13.1 General

The trenches shall not be completely backfilled until all required pressure tests are performed and until the irrigation conduit as placed conforms to the requirements of Specification. Where in the opinion of the Engineer, damage is likely to result from withdrawing sheeting and shoring, the same shall be left in place and cut off at a place level 3.0 meter (1.0 m) below ground surface. Sheeting left in place shall be paid for at the approved rate for that item of work. Trenches shall be backfilled to the ground surface with selected excavated material or other for proper compaction. Trenches improperly backfilled shall be reopened to the depth required for proper compaction, then refilled and compacted to the required density as given in Subsections 3.13.2 and 3.13.3. The surface shall be restored to its original or better condition. Any road shall be replaced and restored.

3.13.2 Lower Portion of Trench

Backfill material shall be deposited in 6-inch (15 cm) maximum thickness layers and compacted with suitable hand tempers to produce a dry density of not less than 95% Standard Proctor laboratory density for cohesive materials or as directed by the Engineer until there is a cover of not less than 12 inch (30 cm) over the pipe. The backfill material in this portion of trench shall consist of approved materials free from stones and lumps.

3.13.3 Remainder of Trench

The remainder of the trench shall be backfilled with material that is free from stones larger than 6-inch (15 cm) in any dimension. Backfill material shall be compacted to 90% Standard Proctor laboratory density for cohesive or equivalent for other materials or as directed by the Engineer.

3.13.4 Borrow Area for Trenches

In case of insufficiency of excavated material and unsuitability of earth for backfilling, conforming to the above Specifications, such material shall be brought from the approved source, by the Contractor.

3.14 EMBANKMENT FOR CANALS / CHANNELS

Embankment for canals / channels shall be constructed as specified in clause 2.5.6 as shown on the Drawings. Maintenance berms and inspection road along the canals shall also be constructed of well compacted approved material in accordance with clause 2.5.6.

3.15 TESTING

3.15.1 Testing by the Contractor

The Contractor shall be responsible for carrying out all field and laboratory tests required to ensure that all fill material placed complies with the Specifications, and that the material is compacted so as to conform to the requirements stated in the Compaction Table over the full depth of each layer. Testing shall be to I3S 1377: 1967 or USBR Earth Manual, Second Edition unless otherwise specified or approved by the Engineer.

Laboratory tests of maximum and minimum dry densities and optimum moisture contents shall be on samples taken adjacent to and including in-situ density test samples.

Maximum dry densities and optimum moisture contents for compaction control by relative compaction shall be derived using Test 12 of BS 1377:1967 as specified in the Compaction Table and maximum and minimum dry densities for compaction control by relative density shall be derived using the test described in Appendix E12 of USBR Earth Manual, second Edition.

Particle size distribution (grading) shall be determined by the appropriate variation of Test 7 of BS 1377: 1967. Tests 7 (A) or 7 (D) shall be used unless otherwise agreed by the Engineer.

Fill density in the field will be determined as follows:

- (a) In fine and medium grained soils, the Contractor shall propose a suitable method which will consist of a large-scale replacement method and it must give consistent and correct results, to the satisfaction of the Engineer.
- (b) In rock fill, filter and drainage layers, water replacement shall be employed using a plastic lining film in a test hole. The hole shall be not less than 10 cubic meter in volume for rock-fill and not less than 1.0 cubic meter in volume for filter and drainage layer.

The location of each field test or sampling point shall be to the approval of the Engineer. The minimum frequency of testing for Control Tests shall be as approved by the Engineer.

The Contractor shall inform the Engineer at least one hour before he proposes to carry out any field test or take a sample so that the Engineer may supervise the test or the taking of the sample. Tests shall be carried out in groups of two or more all in the same layer. The Contractor shall carry out an additional group of tests, designated "Repeat Test", in any fresh layer as designated by the Engineer, after any group of tests, including a group of tests carried out by or on behalf of the Engineer, designated "Engineer's Test", has failed to meet the specified requirements. The acceptability of that layer shall then be determined by the results of the new groups of tests.

The numbering system to be used for recording tests and test results shall be subject to the Engineer's approval and shall clearly differentiate between Control, Repeat, Engineer's and Extra Tests.

Test results and copies of calculations shall be submitted to the Engineer promptly upon completion of the tests.

3.15.2 Engineer's Tests

The Carrying out of any tests by or on behalf of the Engineer shall not relieve the Contractor of any of his responsibilities for testing in accordance with the Specifications. The Contractor shall inform the Engineer of his programme for placement and compaction of fill in sufficient time to allow the Engineer to make arrangements for Engineer's tests to be carried out without delaying the Construction programme.

3.16 MEASUREMENT AND PAYMENT

3.16.1 General: Equipment Fill, Trench Backfill and Stone Apron / Pitching

Measurement under these items will be computed by actual measurements methods and will be made of the number of cubic meter of each material Zone in place and accepted in the embankment fill to the lines, grades and cross sections shown on the Drawings or established by the Engineer.

Payment shall constitute full compensation for constructing the embankment from required borrow areas, quarries and stockpiles including excavating, loading, unloading, rehandling, hauling, processing, moistening, placing and compacting the materials and all other work related to the item.

3.16.2 Riprap Stone Protection for Embankment

Payment will be made for the number of cubic meter measured as provided above at the Contract unit price per cubic meter for Riprap smaller and larger stone protection respectively for embankments.

3.16.3 Stone Protective Layer and Filter under Riprap

Payment will be made for the number of cubic meter measured as provided above at the Contract unit price per cubic meter for Slope Protective Layer and Filter and Riprap.

3.16.4 Gravel Drainage Blanket

Payment will be made for the number of cubic meter measured as provided above at the Contract unit price per cubic meter for Gravel Drainage Blanket.

3.16.5 Impervious Core Fill

Payment will be made for the number of cubic meter measured as provided above at the Contract unit price per cubic meter for Impervious Core Fill.

3.16.6 Sand Filter

Payment will be made for the number of cubic meter measured as provided above at the Contract unit price per cubic meter for Sand Filter.

3.16.7 Sandy Gravel Fill and Filter Under Slope Protection

Payment will be made for the number of cubic meter measured as provided above at the Contract unit price per cubic meter for Sandy Gravel Fill and Filter under Slope Protection.

3.16.8 Sandy Gravel Toe

Payment will be made for the number of cubic meter measured as provided above at the Contract unit price per cubic meter for Sandy Gravel Toe.

3.16.9 Slush Grout

Payment will be made for the number of cubic meter measured as provided above at the Contract unit price per cubic meter for Slush Grout.

3.16.10 Stone Apron

Measurement for payment of Stone Apron at the locations specified will be made to the outlines of the stone in place and accepted according to the thickness of the stone apron shown on the Drawings or establish by the Engineer.

Payment will be made for the number of cubic meter as provided above at the Contract unit price per cubic meter for the Stone Apron at specified locations and shall constitute full compensation for materials and placement of the stone apron including preparation of foundation and all other works related to the item.

3.16.11 Miscellaneous Fills and Backfills around Structures

Measurement will be made of the number of cubic meter of well compacted or lightly compacted fills and backfills in accordance with Subsection 3.12.3 as specified on the Drawings or directed by the Engineer, in place and accepted around the Structures according to the lines and grades as shown on the Drawings.

Payment will be made for the number of cubic meter measured as provided above at the Contract unit price per cubic meter for the respective items as indicated in BOQ and shall constitute full compensation for constructing the fill with the materials obtained from the specified stockpiles or borrow areas including hauling, placing, moistening and compacting the material and all other work related to the item.

3.16.12 Compaction and Backfilling of Trenches

Measurement shall be made of the number of cubic meter of earth acceptably backfilled with well-compacted earth for trenches within the lines and grades shown on the Drawings or as directed by the Engineer.

Payment for compaction and backfilling of trenches shall be made at unit price per cubic meter as stated in the BOQ and shall constitute full compensation for backfilling with the materials obtained from the specified stockpiles or borrow areas including hauling, placing, moistening and compacting the material and all other works related to the item.

3.16.13 Stone Pitching

Measurement for payment for stone pitching at specified locations will be made to the outlines of the stone pitching on the basis of the accepted thickness of the stone pitching as shown on the Drawing and as directed by the Engineer. No extra payment will be made for increased thickness of stone pitching.

Payment for furnishing, transporting and placing stone pitching will be made at the unit price bid per cubic meter in the Bill of Quantities for Stone Pitching. The amount bid shall be full payment for the work specified herein as stone pitching, including preparation of the foundation, placing of the stone pitching and all other works related to the item.

The payment shall be deemed to include the costs of cement grouting at Toe Drain for providing, cement, performing grouting and all the related activities in connection to complete the work as per specifications and drawings to the satisfaction of the Engineer.

3.16.14 Construction of Embankment for Canals/ Channels

Measurement will be made of the number of cubic meter of canal embankment constructed as per Specification and Drawings, and as directed by the Engineer.

Payment will be made of the number of cubic meter of canal embankment as measured above and shall constitute full compensation for the materials from required borrow areas, quarries and stockpiles including loading, unloading, rehandling, hauling, processing, moistening, placing, well compacting the materials and all the works stated in the above BOQ items including preparation of maintenance berms and inspection roads.

SECTION – 4

EMBANKMENT INSTRUMENTATION

4.1 GENERAL

Embankment instrumentation shall be provided according to the provisions herein specified or as directed by the Engineer.

Instrumentation will be required for measurement of hydrostatic pressure, settlements and seismicity in the embankment. In general, two types of instruments will be installed. However additional instruments may be proposed if required.

The standpipe piezometers (Casagrande type) will be installed for pore pressure measurements and surface markers for measurement of settlements at the surface. The Contractor shall furnish and install all apparatus in accordance with the detailed specifications outlined herein or shown on the Drawing and as directed by the Engineer.

4.2 INSTALLATION OF INSTRUMENTATION

(a) General

Instrumentation shall be installed by the Contractor as construction progresses to the lines and elevations shown on the Drawings, under the supervision of the Engineer. Apparatus and associated tubes and other transmitting media shall be installed during the daylight hours or at night only if adequate lighting is provided as approved by the Engineer. No portion of any instrumentation shall be covered until tested and approved by the Engineer. Open ends of all incomplete lines of tubing shall be sealed to exclude foreign matter. It shall be the Contractor's responsibility to protect the apparatus from damage or displacement during the execution of the Works. Any damage or displacement of the apparatus or facilities by the Contractor's operations shall be repaired and / or replace by the Contractor at his own cost. Foundation and embankment piezometers shall be installed at the locations and elevations shown on the Drawings, or as established by the Engineer, as the work progresses. The terms piezometer as used herein shall mean the piezometer tip assembly and connecting tubing, and/or other media required for measuring pore pressure.

(b) Foundation

The Contractor shall drill holes as approved by the Engineer, of size as specified to accommodate equipment of the size to be used for foundation piezometers to depths as indicated on the Drawings. The boreholes shall be thoroughly cleaned before placing instrument. In each hole the Contractor shall install piezometers, complete with tip assembly and connecting tubing as shown on the Drawings or as directed by the Engineer. Clean, saturated well graded sand shall be placed in the hole around each piezometer tip, extending at least 30 cm below and 60 cm above the tip. The hole shall then be backfilled to the bottom of embankment fill with an impervious plug of cement grout as shown on the Drawings.

c) Embankment Piezometer

The embankment piezometer shall be installed in the open pits or trenches at locations shown on the Drawings. Excavation of pits or trenches shall be done by manual methods so as to disturb the adjacent embankment as little as possible. Prior to installation of piezometers and tubing, selected sand shall be placed upon the selected material in accordance with the details shown on the drawings or as directed by the Engineer. No pockets of loose material will be permitted adjacent to the piezometer tips or tubing. Tubing shall be kept in proper orientation; spacing and each riser tube shall be properly tagged. The backfill, compaction of soil in the pits shall be performed by manual methods as directed by the Engineer. Soil tests shall be made by the Contractor to ensure that compaction obtained is at least-equal to that of adjacent embankment. The sand shall be firmly placed to preclude any movement of piezometer within the bedding. Piezometer tubing shall be extended to successively higher elevation as embankment construction proceeds by means of vertical split casing pipe. Splicing of riser pipes will not be permitted and any joint shall have to be authorized by the Engineer in writing only.

d) Surface Settlement Points

The Contractor shall construct surface settlement points as close as practicable to the locations shown on the Drawings, as soon as practicable after embankment has been constructed to the elevation of each such point. Surface settlement points shall be constructed by installing lengths of reinforcement bar vertically into the dam as shown on the Drawings or as directed by the Engineer.

4.3 MEASUREMENT AND PAYMENT

(a) Measurement and Payment

All work under this Section, Instrumentation of Embankments and their Foundations, will be paid for under the following Provisional and Prime Cost Items in accordance with Clause 58 of the Conditions of Contract. No increase in Contract price of any kind will be made due to interference of the work under this Section with the embankment construction or any other work under this Contract.

(b) Install, Operate and Maintain Embankment and other Miscellaneous Instrumentation, Equipment and Appurtenances

The provisional sum for this item will cover installing the approved instrumentation including supplementary instrumentation placed by boring, instrumentation houses and observation stations including earthwork incidental thereto, and such operations incidental to the instrumentation that the Engineer may require, except that construction of buildings and furnishing and installing of electrical work will be covered under the applicable items of the Bill of Quantities.

(c) Furnish Embankment and other Miscellaneous Instrumentation Equipment

The Prime Cost sum will cover furnishing and delivering the approved embankment and other miscellaneous instrumentation to the site of the work.

(d) Construction and Maintain Seepage Measuring Chamber with V Notch

Measurement will be made on lump sum basis to the Contractor for constructing and maintaining seepage measuring chamber with V notch as shown on the drawing and as directed by the Engineer.

Payment shall be deemed to include all expenditures incurred on the related works for the construction and maintenance of seepage measuring chamber with V-notch.

4.4 RAIN GAUGE

Data Logging Rain Gauge shall be fully self-contained battery-powered rainfall data collection and recording system which shall include an event data logger integrated into a tipping-bucket rain gauge. The instrument shall automatically record up to 160 inches of rainfall data that can be used to determine rainfall rates, times, duration and temperature.

The instrument shall record up to 160 in. of rainfall at rates up to 12.7 cm (5 in.) per hour. The Data Logging Rain Gauge system shall be battery powered and includes a Pendant Event data logger, Base Station and a tipping-bucket rain gauge. Easily collect rainfall, time, and duration data, as well as temperature.

SECTION – 5

PLAIN AND REINFORCED CONCRETE

5.1 SCOPE

This section covers the manufacturing, forming, transporting, placing, stripping of forms, finishing and curing of plain and reinforced normal concrete in the structures included herein and as shown in the drawings. The relevant reference standards are listed in sub-sections 5.31 at the end of this section.

5.2 SPECIFICATIONS

The following codes shall be used.

5.2.1 Reinforced Concrete

Reinforced Concrete will be designed in accordance with the applicable provisions of "Building Code Requirements for Reinforced Concrete (ACI 318-89) and commentary ACI (318-89) of American Concrete Institute.

5.2.2 Plain Concrete

Design of Structural Plain Concrete will be based upon the relevant provisions of "Building Code Requirements for Structural Plain Concrete (ACI 318 - 89) and commentary ACI 318 89, of American Concrete Institute.

5.3 COMPOSITION AND QUALITY

Concrete shall be composed of Portland cement, water, fine and coarse aggregates and any admixtures as and when specified. The concrete mixes will be designed by the Contractor under the supervision of the Engineer who will determine the required quality of the concrete for the structures covered by these Specifications. The design strengths of concrete for various parts of the structures shall be as shown on the Drawings.

5.4 CEMENT

5.4.1 General

Generally, Portland cement shall be used for the construction of this Contract.

Cement shall be furnished in sacks or in bulk form as approved by the Engineer. Unless otherwise permitted, cement from not more than two plants shall be used and in general, the product from only one plant shall be used in any particular section of the work. No cement recovered through cleaning sacks shall be used.

5.4.2 Portland Cement

Portland cement shall be Pakistani manufactured, unless otherwise approved by the Engineer. Portland cement shall conform to Pakistan Standard 232 or British Standard BS-12 1978 or later "Specifications for Ordinary and Rapid Hardening Portland Cement" or to ASTM Designation C150-86, "Standard Specifications for Portland Cement".

5-4.3 Tests

Cement shall be sampled at storage site and tested from time to time at the discretion of the Engineer in accordance with the ASTM Designation C150-86 or its equivalent latest British Standards. Expenses for such tests shall be borne by the Contractor. If the tests prove that the cement has become unsatisfactory, it shall be removed from the site immediately. Cement which has been in storage at the project site longer than four months, shall not be used until re testing proves it to be satisfactory.

5.4.4 Transportation of Cement

Transportation of the cement from the factory to the site stores and to the point of use shall be accomplished in such a manner that the cement is completely protected from exposure to moisture. Cement which has been adversely affected by moisture, as determined by the Engineer, shall be rejected. Cement shall be delivered in strong and well made paper and cloth sacks, each plainly marked with the manufacturer's name, brand, type of cement and the weight of cement contained therein. Packages varying more than 3 percent cement from the weight marked thereon may be rejected and if the average weight of packages in any consignment as shown by weighing fifty packages taken at random, is less than that marked on the packages, the entire consignment may be rejected. Packages received in broken or damaged condition shall be rejected or may be accepted only as fractional packages as determined by the Engineer.

5.4.5 Storage

Cement shall be stored in dry, weather tight and properly ventilated structure. All storage facilities shall be subject to approval and shall be such as to permit easy access for inspection and Identification of each consignment. Sufficient cement from a single source shall be in storage at the work site to complete any lift of concrete started. Adequate storage capacity shall be furnished to provide sufficient cement to meet the peak needs of the project. Cement in sacks shall be stored on a damp-proof floor and shall not be piled to a height exceeding 2m (6.5 ft.).

The Contractor shall use cement in the approximate chronological order in which it is received at the site. All empty sacks shall be promptly disposed of as approved by the Engineer.

Cement storage facilities shall be emptied and cleaned by the Contractor when so directed, however, the interval between required cleanings will normally not be less than four months.

Suitable accurate scale shall be provided by the Contractor for weighing the cement in stores and elsewhere on the work if required, and he shall also furnish all necessary test weights.

5.4.6 Delivery and Usage Record

Accurate records of deliveries of cement and its use in the work shall be kept by the Contractor. Copies of these records shall be supplied to the Engineer in such a form

as he may require.

5.5 AGGREGATES

Materials used as aggregates shall conform to ASTM C33-86 "Specifications for Concrete Aggregates" and shall be obtained from sources known to produce satisfactory results for the different specified grades of concrete. The use of aggregates from sources which have not been approved by the Engineer shall not be permitted. The following tests shall be carried out by the Contractor at his own expense to determine the suitability of the material for the intended use:

- Mechanical properties
- Porosity
- Organic impurities
- Clay and Silt contents
- Abrasion and Soundness
- Alkali Reactivity Potential
- Water Soluble Chloride Content

5.5.1 Fine Aggregate for Concrete

Fine aggregate shall conform to provisions of ASTM C33-86 to ensure water lightness and chemical resistance where required.

Fine aggregate for grade A, B and C of concrete shall be well graded natural sand, stone screenings or other inert material of similar characteristics or a combination of these. The whole of it shall be perfectly clean, free from coagulated lumps, soft and flaky particles, shale alkali, organic matter, loam mica and injurious amount of other deleterious substances. Maximum allowable content of silt and other deleterious inert-substances is 5 percent. Material derived from stone unsuitable for coarse aggregate shall not be used as fine aggregate. Fine aggregate derived from stone screenings shall be well shaped, cubical, hard, dense and durable and shall be stacked on a platform so as to adequately protect it from dust and other admixtures.

Grading for the above specified fine aggregate shall be within the following limits, when tested in accordance with ASTM C136 - 84a.

Sieve Size	Percentage Passing (Dry Weight)
9.5 mm (3/8 in)	100
4.75 mm (No. 4)	95 to 100
2.36 mm (No. 8)	80 to 100
1.18 mm (No. 16)	50 to 85
0.60 mm (No. 30)	25 to 60
0.30 mm (No. 50)	10 to 30

Sieve Size	Percentage Passing (Dry Weight)
0.15 mm (No. 100)	2 to 10

Fineness Modulus shall range between 2.3 and 2.60.

5.5.2 Coarse Aggregate for Concrete

Coarse aggregate for grades A, B and C of concrete shall consist of quarried or crushed stone/river run gravel or inert material or a combination of these, durable, sound, cubical and well shaped, free from soft or friable matter or thin elongated pieces, alkali, organic matter or injurious amounts of other deleterious substances. Deleterious inert matter shall not exceed 3 percent.

5.5.3 Storage of Aggregate

Each class of aggregate is to be stored separately and the Contractor is to provide means of ensuring that aggregates are stored on a suitable hard clean surface or platform to prevent contamination from the ground or any other source.

5.5.4 Proportions of Coarse and Fine Aggregates

The nominal ratio of the volume of coarse aggregate to the volume of fine aggregate shall be decided by compression test of concrete cylinders to be furnished by the Contractor. The Engineer may order these ratios to be varied slightly according to the grading of the aggregates by weight, if necessary, so as to produce required grading for the mixtures of coarse and fine aggregate. The Engineer shall get the tests carried out at the Contractor's cost.

At the beginning of the Works and where there is any change in the coarse or fine aggregates or in their source of supply, the Contractor is to have a series of tests on cylinders made representative of and marked as to the aggregates and their grading and mix of concrete. Such cylinders are to be tested in the laboratory under identical conditions, except for small variations in the relative proportions of the coarse and fine aggregates up and down from the best proportions derived from the sieve analysis. The cylinders are to be tested at 3, 7 and 28 days.

5.5.5 Water

Water for washing aggregates, mixing concrete and curing shall be clean and free from harmful matter and shall satisfy the recommendations contained in the Appendix of BS 3148-80 or ASTM D596-83 or equivalent. The concentration of sulphates and chlorides shall be such that the concrete mix as a whole complies with the limits of salts content recommended in the Appendix of BS 3148-80 or ASTM D596-83 or equivalent. The Contractor shall make arrangements to protect water from direct Sun and contamination by wind-blown materials, The Engineer shall order re-testing of water whenever deemed necessary. Water shall meet the following requirements:

Chlorides such as Sodium chloride	Max.	500	ppm
Sulphate such as Sodium Sulphate	Max.	1000	ppm

Impurities	Max.	2000	ppm
Alkali Carbonate and Bicarbonates	Max.	1000	ppm

Water for curing concrete shall have a pH value not lower than 6 or greater than 9 and shall not contain impurities which cause discoloration of concrete,

5.6 CONCRETE MIX STRENGTH

5.6.1 Strength

In addition to the mix design parameters pursuant to structural characteristics, chemical resistance and durability requirements, the concrete mixes shall also conform to the placing systems employed.

The concrete shall be one of the following three different grades to be paid for at their respective unit prices designated.

Grade of Concrete	Type of Concrete	Minimum Compressive Strength	Max. size of Aggregate (in)
		Tested at 28 days	
A	Normal Structural Steel	3000 - psi	3/4-1.5
B	Massive	3000 - psi	3
C	Plain	1500-2000 - psi	3

However, the actual concrete mix requirement shall consist of proportioning and mixing for the following strengths when tested in the form of cylinders; test shall be made for each grade of concrete. The cylinders are to be made, cured, stored, transported and tested in accordance with ASTM C 39 - 86. The tests are to be carried out at a testing laboratory approved by the Engineer. All such tests shall be carried out at the expense of the Contractor.

5.6.2 Water Cement Ratio

In general, the Engineer 's design will provide for water cement ratios by weight (exclusive of water absorbed by the aggregates), which will be determined on the basis of producing concrete having suitable workability, density, impermeability, durability and the required strength without the use of excessive amounts of cement.

5.6.3 Consistency

Proportions of ingredients shall vary to achieve the desired concrete consistencies when tested, conforming to the following slump requirements or as desired by the Engineer. The slump shall be determined in accordance with ASTM C143-78.

Use of Concrete	Minimum & Maximum Slump (mm)
Columns, Beams, Slabs and Slabs on ground.	25 to 75 (1") (3")
Plain or Reinforced Foundations,	25 to 100

Footings.	(1")	(4")
-----------	------	------

In all cases, the proportions of aggregates for concrete shall be such as to produce mixtures which will work readily into the corners and angles of the forms and around the reinforcement without permitting the segregation of materials or laitance formation. Uniformity in concrete consistency from batch to batch shall be ensured.

5.7 MEASUREMENT OF MATERIALS

The coarse and fine aggregate are to be weighed or accurately measured to the Engineer's satisfaction. In no event they are to be measured by the shovel or barrow.

5.8 MIXING METHODS

The concrete shall be mixed in an approved mechanically operated batch mixer. The mixer is hopper and working platforms shall be protected from sun, rain and wind.

The aggregates and cement shall be mixed together before adding water until the concrete is of even colour and consistency throughout. Dirt and other undesirable substances shall be excluded. Water shall not be added indiscriminately from a hose or can. All concrete shall be thoroughly mixed by a modern reliable batch mixer to produce maximum output of concrete necessary to complete the Works within the specified time without reducing the required mixing time. Concrete shall be mixed in the concrete mixers for the duration required for uniform distribution of the ingredients to produce a homogenous mass of consistent colour but for not less than 1.5 minutes. The mixer shall be operated by trained operators, who have previous experience of running and operation of concrete mixers.

At the conclusion of mixing, the mixer and all handling plants shall be thoroughly cleaned out before the concrete remaining in them has had time to set.

No concrete shall be mixed by hand without the Engineer's written consent, and such consent shall be given only for small quantities in special circumstances.

5.9 TEST OF CONCRETE

5.9.1 Strength Test during the Work

Strength tests of the concrete placed during the course of the work will be made by the Engineer in an approved laboratory at the Contractor's expense. The Contractor shall assist the Engineer in obtaining, for control purposes, such number of cylinders and/or beams as the Engineer may direct, but in general, three cylinders and/or beams, taken from each 10 to 50 cu.m or fraction thereof, or from each days pour, whichever is less of each grade of concrete placed, shall govern. Test specimen will be made and cured in accordance with the applicable requirements of ASTM Designation C31-87, "Practices for Making and Curing Concrete Compressive and Flexural Test Specimens in the Field". Cylinders and beams will be tested in accordance with the applicable requirements of ASTM Designation C39-86, "Standard Method of Test for Compressive Strength of Cylindrical Concrete Specimens" and ASTM Designation C78-81, "Standard Method of Test for Flexural

Strength of Concrete (Using Simple Beam with Third Point Loading)". The test result will be based on the average of the strength of the test specimens except that if one specimen in a set of three shows manifest evidence of improper sampling, moulding, or testing, the test result will be based on the average of the remaining two specimens. If two specimens out of a set of three show such defects, the results of the set will be discarded and average strength determined from test results of the other two sets. The standard age of test will be 28 days. If the average of the strength test of the specimen cured under laboratory controls, for any portion of the work, falls below the minimum allowable compressive or flexural strength at 28 days required for the grade of concrete used in that portion, the Engineer may change the proportions of the constituents of the concrete, as necessary to secure the required strength for the remaining portions of the work. If the average strength of the specimens cured under actual field conditions as specified herein before falls below the minimum allowable strength, the Engineer will make such changes in the conditions for temperature and moisture under which the concrete work is being placed and cured as may be necessary to secure the required strength.

5.9.2 Tests of Hardened Concrete In or Removed from the Structure

Where the results of the strength tests of the control specimens indicate the concrete as placed does not meet Specification requirements or where there is other evidence that the quality of the concrete is below specification requirements, core-boring tests will be made by the Engineer in accordance with ASTM Designation C42-84a Standard Method of Obtaining and Testing Drilled Cores and Sawed Beams of Concrete. In the event that the core-boring test indicates that the concrete placed does not conform to the Drawings and Specifications, the Contractors shall take measures as prescribed by the Engineer to correct the deficiency. If a strength deficiency is found and is due to the Contractor's fault or negligence, the entire cost of replacing faulty concrete shall be borne by the Contractor who shall also reimburse the Employer for the cost of making tests. Otherwise, payment for removing and replacing faulty concrete will be made under applicable Items of the Bill of Quantities insofar as they are applicable and as Day Work where not classifiable under the Items of the Bill of Quantities.

5.10 TRANSPORTATION OF CONCRETE

Concrete shall be conveyed from mixer to the place of final deposit as rapidly as practicable, by methods which will prevent segregation or loss of ingredients and in accordance with the latest edition of ACI 304" Recommended Practice for Measuring, Mixing, Transporting and Placing Concrete".

Any wet batch hopper through which the concrete passes shall be conical in shape. There shall be no vertical drop greater than 1.50 m except where suitable equipment is provided to

prevent segregation and where specifically authorized belt conveyers, chutes, or other similar equipment shall not be permitted for Conveying concrete except where the use of this equipment is approved in writing by the Engineer, in advance of any use. Each type or grade of concrete shall be visually identified by placing a coloured tag or marker on the bucket may be positively identified and placed in the structure forms in the desired position.

5.11 PLACING

5.11.1 General

Concrete placing shall follow the Recommended Practice for Measuring, Mixing, Transporting and Placing Concrete, latest ACI 304 requirement. No concrete shall be placed until all formwork, reinforcement, installation of parts to be embedded, bracing of forms and preparation of surface involved in the placing and the method of placement have been approved by the Engineer. Approval of the method of placement proposed will not relieve the Contractor of his responsibility for its adequacy and he shall remain solely responsible for the satisfactory construction of all work under the Concrete.

Before concrete is placed, all surfaces upon or against which concrete is to be placed, shall be free from standing water, mud, debris or loose material. All surfaces of form and embedded material that have become encrusted with dried mortar or grout from concrete previously placed shall be cleaned of all such mortar or grout before the surrounding or adjacent concrete is placed. The surfaces of absorptive material against or upon which concrete is placed shall be moistened thoroughly so that moisture will not be drawn from the freshly placed concrete. The depositing of concrete shall be regulated so that the concrete may be effectively compacted with a minimum of lateral movement in to horizontal layers approximately 0.40 m in thickness. No concrete that has partially been hardened or contaminated by foreign materials shall be deposited in the structure, nor shall re-tampered concrete be used unless approved by the Engineer. The surfaces of construction joints shall be kept continuously wet for at least eighteen hours during the twenty four hours period prior to placing concrete except as otherwise directed by the Engineer. All free water shall be removed and the construction joint shall be completely surface dry prior to placement of concrete. All concrete placing equipment and methods shall be subject to approval. Concrete placement will not be permitted, when in the opinion of the Engineer weather conditions prevent proper placement and consolidation.

5.11.2 Placing Concrete under Water

Concrete shall not be placed under water except where inevitable in which case approval must be sought from the Engineer and the work carried out under his immediate supervision. In this case the method of placing shall be as hereinafter specified.

Concrete deposited under water shall be of the strength as specified on drawings

with a minimum cement content of 400 kg per cubic meter of concrete.

The slump of the concrete shall be maintained between 10 and 20 cm. To prevent segregation, it shall be carefully placed in a compact mass, in its final position, by means of a tremie, a bottom-dump bucket, or other approved means, and it shall not be disturbed after being placed, Water must not be allowed to flow past the fresh concrete surface.

A tremie shall consist of a tube having a diameter of not less than 25 cm constructed in sections having flanged couplings fitted with gaskets with a hopper at the top. The tremie shall be supported so as to permit free movement of the discharge end over the entire top surface of the work and so as to permit rapid lowering when necessary to retard or stop the flow of concrete. The discharge end shall be closed at the start of work so as to prevent water entering the tube and shall be completely submerged in concrete at all times; the tremie tube shall be kept full to the bottom of the hopper. When a batch is dumped into the hopper, the flow of concrete shall be induced by slightly raising the discharge end, but always keeping it in the placed concrete. The flow shall be continuous until the work is completed.

When the concrete is placed with a bottom-dump bucket, the top of the bucket shall be open. The bottom doors shall open freely downward and outward when tripped. The bucket shall be completely filled and slowly lowered to avoid backwash. It shall not be dumped until it rests on the surface upon which the concrete is to be deposited and when discharged ' shall be withdrawn slowly until well above the concrete.

Dewatering may proceed when the concrete seal is sufficiently hard and strong. All laitance or other unsatisfactory material shall be removed from the exposed surface by scraping, chipping or other means which will not injure the surface of the concrete.

5.12 COMPACTING CONCRETE

All concrete, except that in blinding layers and in-situ-concrete in very small sections, shall be compacted by vibration. After any necessary hand spading, working and ramming into place, each layer of concrete shall be compacted with mechanical immersion vibrators of types approved by the Engineer.

The immersion vibrators shall produce vibration of a frequency not less than 6000 impulses per minute. Under no circumstances shall be immersion vibrators be allowed to come into contact with reinforcement or shuttering. Immersion vibrators shall penetrate vertically for a few inches into any previous unset layer in order to establish a satisfactory bond, but no concrete shall be vibrated in such a manner as to cause injury to concrete (already set or otherwise) in other parts of works. Care shall be taken to keep the vibrators vertical, to insert them at regular intervals and withdraw them slowly to prevent the formation of voids, so that the entire mass of the concrete is properly compacted. Haphazard or random penetration of the vibrators without sufficient depth of insertion shall be avoided. A sufficient number of

vibrators shall be used to ensure compaction of each batch of concrete before the next batch is delivered. At least one extra vibrator shall be in hand for emergency use.

Vibration shall be supplemented by hand punning with approved small diameter smooth steel rods with rounded ends in order to achieve complete compaction around reinforcement and other embedded fittings and a completely dense mortar finish against the shuttering.

Excessive vibration shall be avoided and on no account shall vibration be continued after a good surface finish, without free water, has been achieved. Vibration and punning shall be just sufficient to produce a dense, homogenous concrete properly filling the moulds and free from air voids, segregation, bleeding, honeycombing and other imperfections. Only highly skilled operators and workmen, subject to constant supervision, shall be employed in vibrating and punning concrete.

5.12.1 Time Interval between Mixing and Placing

Concrete mixed in stationary mixers and transported by non-agitating equipment shall be placed within thirty minutes after it has been mixed, unless otherwise authorized. When a truck mixer or agitator is used for transporting concrete, the concrete shall be delivered to the site of the work and discharge shall be completed within 1.5 hours after introduction of the cement to the aggregates. The concrete shall be placed within 20 minutes after it has been discharged. In all cases, concrete shall be placed and compacted well within the initial setting time.

5.13 CONCRETE FINISHES

Concrete finishes shall be made in accordance with the provision of ACI 301-84 or as directed by the Engineer. Workmanship in shuttering and concreting shall be such that concrete work shall normally require retouching and the surfaces being dense, watertight and, where steel shuttering has been used, perfect and smooth. Should there be faults in these respects, the Contractor shall cut out and replace the whole of the lift-concerned or such amount as the Engineer decides, or make good if permitted by the Engineer and to his approval. Concrete which is honeycombed or otherwise shows voids shall invariably be cut out and replaced in an approved manner as directed by the Engineer.

Any making good shall be carried out immediately after striking the shuttering and shall be restricted to light rubbing down with wet carborundum or the approved correction of minor blemishes. In no circumstances shall surfaces be made good with cement or washes or rendering.

Exposed concrete surfacing not requiring shuttering and not subsequently to be given extra finishes shall be given perfectly dense smooth finish with a wooden float.

Where concrete slabs, ducts, bases or machine plinths will themselves form the finished floor surface the concrete shall be towelled immediately after the first laying process only just sufficiently to give a level surface. Thereafter, when the concrete has stiffened to a condition such that a hard compacted surface can be obtained without bringing up laitance, a final surface towelling shall be given with a steel float to produce a smooth finish.

5.14 PLACING TEMPERATURE

The temperature of concrete when it is being placed shall conform to the requirements herein specified for thin, moderate and heavy concrete sections and mass concrete. The Engineer's determination as to the type of section and applicable placing temperatures shall govern.

Concrete shall be placed at temperature as follows;

Concrete for delivery to the forms at the coolest temperature which is practicable to produce under current conditions, but in no case in excess of 32 C^o. Except as otherwise determined by the Engineer, Section to which this provision will apply, shall be considered to be sections ten feet and less in thickness when screened and/or formed on both faces, and five feet and less in thickness when one face is placed against earth, rock or previously placed concrete.

If concrete is placed when the weather is such that the temperature of the concrete would exceed the limits herein specified, as determined by the Engineer, the Contractor shall employ effective means, such as preceding of aggregates and mixing water and placing at night, as necessary, to maintain the temperature of the concrete, as it is placed, below the maximum limits specified herein.

5.15 CURING OF CONCRETE

5.15.1 General

Curing of all concrete including repair work concrete shall conform to the recommendation given in ACI 308 "Standard Practice for Curing Concrete". Unless otherwise specified or ordered by the Engineer all concrete shall be cured by water. It shall be kept wet continuously for at least fourteen (14) days after placement. It shall be covered with water saturated material like gunny bags, canvas/ clean sand, matting/ etc. or any other improved method duly approved by the Engineer.

Shuttering and exposed faces of concrete and mortar shall be covered by at least 3 thicknesses of approved stout hessian kept continuously cool and wet by an efficient and comprehensive system of sprinklers and diffused jets of water, with appropriate temporary drainage arrangements, for at least 14 days after placing,

As an alternative to continuous curing with water after stripping of shuttering a proprietary membrane method of curing may be used provided that it is used strictly in accordance with the manufacturer's instructions, is colored to show its presence, contains no bituminous substance, does not prejudice the appearance of permanently exposed concrete surfaces and is in all other respects to the approval of the Engineer. Wherever practicable, both faces of concrete structures shall be appropriately treated in order to prevent tensile stresses due to differential shrinkage or temperature across the section. Furthermore, the Contractor shall continue to provide facilities for covering and/or keeping wet such exposed surfaces of the Work as are in the opinion of the Engineer liable at any time to be damaged by weather.

At no time shall any further work involving concrete proceed until the Contractor has satisfied the Engineer that all such work previously carried out is being protected and cured in accordance with this clause.

5.15.2 Curing Pre-cast Concrete Members

Pre-cast concrete members shall be cured for not less than 7 days by the water method or by steam curing, at the option of the Contractor. Steam curing for pre-

cast members shall conform to the following provisions:

- After placement of the concrete/ members shall be held for a minimum 4 hours pre-casting period.
- To prevent moisture loss on exposed surfaces during the pre-steaming period, members shall be covered immediately after casting or the exposed surfaces shall be kept wet by fog spray or wet blankets.
- Enclosures for steam curing shall allow free circulation of steam about the member and shall be constructed to contain the live steam with a minimum moisture loss. The use of tarpaulins or similar flexible covers will be permitted, provided they are kept in good repair and secured in such a manner to prevent the loss of steam and moisture.
- Steam at jets shall be low pressure and in a saturated condition. Steam at jets shall not impinge directly on the concrete, test-cylinders, or forms. During application of the steam, the temperature rise within the enclosure shall not exceed 20 degrees C per hour. The curing temperature throughout the enclosure shall not exceed 65°C and shall be maintained at a constant level for a sufficient time necessary to develop the required compressive strength. Control cylinders shall be covered to prevent moisture loss and shall be placed in a location where temperature is representative of the average temperature of the enclosure.
- Temperature recording devices that will provide an accurate continuous permanent record of the curing temperature shall be provided. A minimum of one temperature recording device per 60 meters of continuous bed length will be required for checking temperature,
- Curing of pre-cast concrete will be considered completed after a termination of the steam curing cycle

5.16 PREPARATION OF EARTH SURFACES

Before concrete is placed in or against any excavation or filling, the surface of such earthwork shall have been compacted and shall be free from running and standing water, oil and other deleterious matter. Loose earth and other material shall be removed. The excavation or filling shall be damp but not wet and special precautions shall be taken to prevent groundwater from damaging green concrete or causing movement of the concrete.

Immediately after the excavation or filling has been trimmed and prepared as above, the exposed foundation shall be protected by a blinding layer or "No-fines" concrete or of cement mortar or other protection as show on the Drawings or ordered by the Engineer. Such blinding layers and coatings shall be thoroughly cleaned and moistened before further concrete work is placed thereon.

Reinforced concrete shall not be cast against an unprotected face of earth or any other material liable to become loose or to slip; the greatest possible care shall be taken to avoid

falls of material on to the concrete, by leaving the timbering in place (if permitted) or by recovering the timbering in small depths and lengths at a time and by any other approved means. If any such falls occur, all soiled concrete shall be removed and replaced at Contractor's own cost.

5.17 CASTING SECTIONS AND CONSTRUCTION JOINTS

(a) General

The concrete in each integral part of a structure shall be placed continuously, and the Contractor will not be allowed to commence work on any such part unless sufficiently inspected and approved material for the concrete is at hand, and his forces and equipment are sufficient to complete the part without interruption in the placing of the concrete. Construction joints shall be made only where located on the plans or shown in the pouring schedule, unless otherwise approved.

If not detailed on the plans, or in the case of emergency, construction joints shall be placed as directed. Shear keys or inclined reinforcement shall be used where necessary to transmit shear or bond the two sections together. When shear keys or inclined reinforcement are not provided, the concrete shall be roughened as directed. Joints in the concrete due to stopping work shall be avoided as far as possible. Such joints, when necessary, shall be constructed to meet the approval of the Engineer.

When the placing of concrete is temporarily discontinued the concrete, after becoming firm enough to retain its shape, shall be cleaned of laitance and other objectionable material to a sufficient depth to expose sound concrete. Where a "feathered edge" might be produced at a construction joint, as in the sloped top surfaces of a wing wall, an inset formwork shall be used to produce an edge thickness of not less than 15 centimeters in the succeeding layer. Work shall not be discontinued with 50 centimeters of the top of any face, unless provision has been made for a coping less than 50 centimeters thick, in which case, if permitted by the Engineer, the construction joint may be made at the underside of coping.

Immediately following the discontinuance of placing concrete all accumulations of mortar splashed upon the reinforcing steel and the surfaces of forms shall be removed. Dried mortar chips and dust shall not be puddle into the unset concrete. Care shall be exercised, during the cleaning of the reinforcing steel, not to injure or break the concrete steel bond at and near the surface of the concrete.

(b) Box Culverts

Vertical construction joints shall be at right angles to the axis of the culvert.

In general, the base slab or footings of box culverts shall be placed and allowed to set before the remainder of the culvert is constructed. In this case, suitable provision shall be made for bonding the sidewalls to the culvert base, preferably by means of raised longitudinal keys so constructed as to prevent, as far as possible, the

percolation of water through the construction joint.

In the construction of box culverts 1.25 meters or less in height, the sidewalls and top slab may be constructed as a monolith. When this method of construction is used, necessary construction joints shall be vertical and at right angles to the axis of the culvert.

In the construction of box culverts more than 1.25 meters in height the concrete in the walls shall be placed and allowed to set before the top slab is placed. In this case, appropriate keys shall be left in the side walls for anchoring the cover slab.

If possible, each wing-wall shall be constructed as a monolith. Construction joints, where unavoidable, shall be horizontal and so located that no joint will be visible in the exposed face of the wing wall above the ground line.

(c) Construction Joints

Construction joints shall be made only where shown on the Drawings or called for in the pouring schedule, unless otherwise approved by the Engineer. If not detailed on the Drawings, construction joints, also in case of emergency shall be placed to meet the approval of the Engineer. Shear keys or reinforcement shall be used, unless otherwise specified, to transmit shear or to bond the two sections together.

Before depositing new concrete on or against concrete which has hardened, the forms shall be retightened. The surface of the hardened concrete shall be roughened as required by the Engineer, in a manner that will not leave loose particles of aggregate or damage concrete at the surface- It shall be thoroughly cleaned of foreign matter and laitance. When directed by the Engineer the surface of the hardened concrete which will be in contact with new concrete shall be washed with water to his satisfaction, and to ensure an excess of mortar at the juncture of the hardened and the newly deposited concrete, the cleaned and watered surfaces, including vertical and inclined surface, shall first be thoroughly covered with a coating of mortar of the same proportion of sand and cement as the class of concrete used against which the new concrete shall be placed before the grout or mortar has attained its final set.

The placing of concrete shall be carried continuously from joint to joint. The face edges of all joints which are exposed to view shall be carefully finished true to line and elevation.

5.18 FORM WORK

The Contractor shall submit, for the approval of the Engineer full proposals and design calculations for all form work and proposals for the period of time to elapse before each item of the shuttering is struck. Notwithstanding the approval of the Engineer to any actual shuttering or proposals for its striking, the Contractor shall retain complete responsibility for its adequacy as to the provisions of this clause and for any consequences of the striking being

premature or harmful. In general, the minimum time for the removal of form work shall be as under:

	Form Work	Normal Weather
a)	Form work of vertical surface such as walls and columns faces.	3 * days
b)	Beams and slabs	14 * days
c)	Sides of Beams Caps and other parts	5 * days
d)	Mass Concrete	3 * days

* Notional values of time span to the point of striking forms are subject to change depending on the results of concrete age versus strength tests.

Form work shall be designed with easily sealed access hatches for inspection purposes and for removal of water and deleterious materials, and with connections to facilitate striking without damaging the concrete. Form work for soffits of slabs shall be erected with an upward camber of 6 mm for each 3 m. of span. When props are to be left in position under slabs the shuttering shall be made and removed in such a way that the props are not disturbed in any way.

A tolerance of plus or minus 3 mm in line or level will normally be permitted after erection of the shuttering which shall nevertheless be sufficiently strong, stiff and rigidly braced against loads due to the wet concrete and vibration and against constructional loads, to remain true to the line and level accepted before concreting. It shall be sufficiently watertight ensure that there shall occur no "fine" or escape of mortar at joints or of liquid from the concrete.

All exterior angles for concrete work no permanently buried in the ground shall be given 19mm x 19mm chamfers unless otherwise indicated on the Drawings.

Timber for shuttering shall be well seasoned, free from loose knots, splits, projecting nails and the like and from any adhering foreign matter.

Steel shuttering shall be used to produce a fair face concrete with only a faint but consistent pattern of plate marks on exposed concrete surfaces. The shuttering shall be assembled from wrought tongued and grooved boarding, true and tightly fitted with joints as necessary, the whole surface and all edges being rendered smooth before and after oiling. Bearing in mind the quality of the finish required, wrought, plain-edged and butt-joint boarding may replace the tongued and grooved boarding or purpose-made steel - faced shutters of first-class quality solely at the discretion of the Engineer.

Rough shuttering shall be used for surfaces to be buried in the ground and shall be assembled from sawn boards with smooth and true edges or from approved steel shutters. In either case all joints shall be suitably filled.

The inside faces of all shuttering shall be treated with an approved material to prevent

adhesion of the concrete, all such materials being kept clear of the reinforcement and other items to be embedded.

Shuttering shall be struck by static force alone without shock, vibration or damage to the concrete. Shuttering being reused shall be thoroughly repaired and cleaned before re-assembly.

5.19 TOLERANCES

The Contractor is to complete all works including formwork, placement, curing, etc, so as to ensure the concrete surfaces will conform to the specified tolerance limits given in ACI 316 and 347. Where tolerances are not stated in the specifications or the drawings, maximum permissible deviations from established lines, grades and dimensions shall conform to the tolerances given hereinafter:

These tolerances are not cumulative.

Concrete work not meeting the tolerance requirements will be rejected unless an acceptable repair work is allowed by the Engineer.

5.19.1 Cast in Place Concrete

- (a) Variation from plumb (or the specified better for inclined walls).
- i) In the lines and surfaces of piers, walls and in arises.
 - In any 3m length or height 6 mm
 - In any 6m height 10 mm
 - Maximum for the entire length or height 25 mm
 - ii) For exposed corner piers, control - joint grooves and other conspicuous lines
 - In any bay or 6 m length or height 6 mm
 - Maximum for the entire length or height 12 mm
- (b) Variation from the level or from the grades specified on the drawings.
- i) In slab soffits, beam soffits and in arises measured before removal of supporting shores.
 - In any 3m height 6 mm
 - In any bay or 6 m length 10 mm
 - Maximum for the entire length 19 mm
 - ii) In exposed lintels, sills, parapets, horizontals grooves and other conspicuous lines.
 - In any bay or 7 m length 6 mm
 - Maximum for the entire length 12 mm
- (c) Variation of the linear structure lines from established position in plan and related

	position of piers and walls.	
-	In any bay or 6 m length	12 mm
-	Maximum for the entire length	25 mm
(d)	Variation in the sizes and locations of sleeves, floor openings, and wall openings	
	6 mm	
(e)	Variation in cross-sectional dimensions of columns and beams and in the thickness of slabs and walls.	
-	Minus	6 mm
-	Plus	12 mm
(f)	Footings	
	(Tolerances apply to concrete dimensions only, not to positioning of vertical reinforcing steel, dowels, or embedded items).	
(i)	Variation in dimension in plan	
-	Minus	12 mm
-	Plus	50 mm
(ii)	Misplacement or eccentricity 2% of the footing width in the direction of mis-placement but no more than 50 mm	
(iii)	Thickness	
-	Decrease in specified thickness	5%
-	Increase in specified thickness	No limit

5.20 CONCRETE FOR SECOND STAGE AND BLOCKOUTS

Blockouts for equipment and fittings and for such other works as indicated or directed shall be provided as indicated on the Drawings. After the said equipment and fittings have been installed and adjusted in their final location, the block out recesses shall be filled with concrete. Before installing the components to be embedded in block out concrete, and before depositing any block out concrete, the concrete surfaces of the block out shall be cleaned in the manner specified for cleaning construction joints.

Second stage concrete for filling the openings left for the installation of equipment and fittings shall be anchored to the first stage concrete. The size and spacing of the concrete fixing sockets, if any, to be embedded in the first stage concrete shall be subject to the approval of the Engineer. Different components of structures to be built from second stage concrete indicated on Drawing as second stage shall be connected to the first-stage through dowels. Dowels not shown in first stage concrete Drawings shall be placed and fixed in position by drilling hole in concrete as approved by the Engineer.

5.21 REPAIR OF CONCRETE GENERAL**5.21.1 General**

Concrete that is damaged from any cause; concrete that is honeycombed/ fractured, or otherwise defective; because of excessive surface depressions, must be excavated and built up to bring the surface to the prescribed lines; shall be removed and replaced with dry pack mortar, or concrete, as hereinafter specified. Repair of concrete shall be performed only by skilled workmen and within 24 hours of removal of forms. The Contractor shall keep the Engineer advised as to when repair of concrete will be performed. Unless an inspection is waived in each specific case, repair of concrete shall be performed only in the presence of the Engineer. Repairs shall be made in accordance with the procedures approved by the Engineer.

5.21.2 Materials

All materials used in the repair of concrete shall conform to the applicable requirements of the Specifications.

5.21.3 Protrusions

Where bulges and abrupt irregularities protrude outside the specified limits on formed surfaces not to be concealed permanently, the protrusions shall be reduced by bush-hammering and grinding so that the surfaces are within the specified limits.

5.21.4 Depressions**a) General**

All fillings for depressions shall be bonded tightly to the surfaces of holes and shall be sound and free from shrinkage cracks and drummy areas after the fillings have been cured and have dried. All fillings in surfaces of structures prominently exposed to public view shall contain sufficient white Portland cement to produce the same colour as that of the adjoining concrete. Repairs shall be made with concrete filling, mortar filling or dry-pack filling except where repairs with epoxy concrete and/or epoxy mortar are directed to be made by the Engineer. Concrete, mortar or dry pack filling shall each be mixed in proportions approved by the Engineer to produce a repair at least equivalent in strength, density and durability to the concrete in which the repair is required.

b) Concrete Filling

Concrete filling shall be used for holes extending entirely through concrete sections; for holes in which no reinforcement is encountered and which are greater in area than 0.1 square meter and deeper than 10 cm; and for holes in reinforced concrete which are greater in areas than 0.05 square meter in area and which extend beyond the reinforcement.

c) Mortar Filling

Mortar filling, placed under impact by use of a mortar gun, may be used for repairing defects on surfaces, not exposed to public view where the defects are too wide for dry-pack filling and too shallow for concrete filling and no deeper than the far side of the reinforcement that is nearest to the surface.

d) Dry pack Mortar Filling

Dry pack mortar fillings shall be used for filling holes having a depth nearly equal to, or greater than, the least surface dimension; for narrow slots cut for repair of cracks; for grout pipe recesses; and for tie rod fastener recesses as specified. Dry pack mortar shall not be used for filling behind reinforcement or for filling holes that extend completely through a concrete section. If removal of the ends of form ties results in recesses, the recesses shall be filled with dry pack mortar provided that filling of recesses in surfaces upon or against which fill material or concrete is to be placed will be required only where the recesses are deeper than 25 mm in walls less than 305 mm thick.

e) Surface Finishes of Repaired Areas

The Contractor shall correct all imperfections on the concrete surfaces as necessary to produce surfaces that conform to the requirements specified for the adjacent area Sub-section "Finishes and Finishing". Fins and encrustations shall be neatly removed from the surfaces.

5.22 EPOXY CONCRETE AND MORTAR

5.22.1 Mixing and Batching

a) Epoxy Binder

Prior to mixing, the two components of the epoxy resin binder shall be conditioned to 15°C to 21°C. The two components shall be combined with constant stirring, and the stirring shall be continued until a uniform mixture is obtained. The rate of mixing should be such that entrained air is held to a minimum. A power-driven (air or spark proof) mixer with propeller-type blade operating at a maximum of 500 rpm shall be used for mixing the two components of the epoxy resin binder and a hemispherical bottomed polyethylene or metal container shall be used for the mixing.

b) Epoxy Concrete

Epoxy binder shall be prepared as specified above, and after the two components have been thoroughly mixed, shall be transferred to large metal pans and the aggregates added in recommended and approved

proportion as directed by the Engineer.

General: The fine aggregate shall be added to the epoxy resin binder and the material shall be mixed until a rich mortar consistency is attained. The coarse aggregate shall then be added and the epoxy concrete thoroughly mixed.

c) Epoxy Mortar

Epoxy binder shall be prepared as specified above in para (a) above Epoxy binder, and after the two components have been thoroughly mixed, shall be transferred to large metal pans and the fine aggregate added in recommended and approved proportions as directed by the Engineer. The fine aggregate shall be added to the binder gradually and mixing continued until all particles are coated.

5.22.2 Temperature, Moisture Protection for Epoxy Mortars and Concrete

Epoxy concrete and mortar shall be placed and repairs shall be made when the atmospheric and concrete temperature are above 5°C and less than 35°C and remain in this range for a period of at least 24 hours. If the work is required to be done at temperatures lower or higher than those specified; approved means as recommended by the manufacturer of the epoxy binder and approved by Engineer shall be provided to raise or lower the ambient and concrete temperatures as required for satisfactory work. Such means will include heating or cooling equipment and necessary shelters. If temperatures below 5°C are anticipated during the cure-out or hardening period of the epoxy-concrete or mortar, heated enclosures shall be maintained over the repair area with care taken to avoid localized heating or hot-spots. Circulating air shall be used to ensure the surface temperatures do not exceed 35°C, during curing. Epoxy resin concrete and mortar shall be placed only on sound, clean dry surfaces. Suitable methods shall be used to dry and to maintain dry the contact surfaces of the concrete to which the epoxy concrete or mortar is to be applied. All repairs shall be protected from rain or seepage water for at least 24 hours and from all types of traffic for a period of 72 hours.

5.22.3 Preparation and Placing

a) Epoxy Concrete

All fines, dust, and other loose material on the contact surface shall be removed by scrubbing with a stiff bristle brush followed by washing. The dry, cleaned surfaces shall receive a prime coat of epoxy resin. The prime coat shall be applied in a thin coat and briskly scrubbed into the dry concrete surface with a stiff bristle brush. Placement of the epoxy resin concrete shall be delayed until the prime coat becomes tacky. The epoxy resin concrete shall be placed in layers not over 100 mm in thickness. The thickness of courses and time interval between courses, shall be such that the temperature of the epoxy concrete does not exceed at any time during hardening. Mechanical plate, screed, or float vibrators or hand tampers

shall be used to consolidate the epoxy concrete. Excess epoxy concrete which becomes spread on the adjacent surfaces of hardened concrete shall be removed before it hardens.

b) Epoxy Mortar

Defective concrete in areas as determined by the Engineer shall be repaired with the aid of a saw cut at least 25 mm outside the faulty area. The concrete between the saw cut and the edge of the faulty area and the concrete throughout the area shall be chipped out to solid concrete. The cavity thus formed shall be thoroughly cleaned with compressed air, sand blasting or other method to remove all loose material. The dry, cleaned surfaces of the cavity shall receive a prime coat of epoxy resin binder of composition as recommended by the manufacturer of the epoxy. The prime coat shall be applied in a thin coating and scrubbed into the surface with a stiff bristle brush. Placement of epoxy resin mortar shall be delayed until the prime coat becomes tacky. The epoxy mortar shall then be placed in the cavity in layers not exceeding 25 mm in thickness. The time interval between placements of additional layers shall be such that the temperature of the epoxy resin mortar does not exceed 60°C at any time during hardening. Mechanical plate, screed or float vibrators or hand tampers shall be used to consolidate the epoxy resin mortar. Excess epoxy resin mortar, which becomes spread on the adjacent surfaces of the hardened concrete, shall be removed before it hardens.

5.22.4 Health and Safety Precautions

- Full face shields shall be used during all mixing and blending operations and for placing operations as required.
- Protective skin creams of a suitable nature for the operations shall be used.
- Portable eye washing facilities shall be maintained at mixing, batching and placing operations.
- Adequate fire protection shall be maintained at all mixing and placing operations.
- Smoking or the use of spark or flame producing devices is prohibited within 15 meters of mixing and placing operations.
- The mixing, placing, or storage of solvent is prohibited within 15 meters of any vehicle, equipment, or machinery which could be damaged from fire or could ignite vapors from the material.
- Contaminated clothing which cannot be decontaminated shall be burned at an approved burning area at the end of each working day.
- Facilities shall be provided for decontamination of clothing and equipment

at the job site.

- Care should be taken in handling solvent for cleaning equipment to avoid problems of toxicity, fires, and possible explosions.
- Adequate ventilation shall be provided.

5.23 FINISHES AND FINISHING

5.23.1 General

Allowable deviations from plumb or level and from the alignment, profile grades, and dimensions shown on the Drawings or specified by the Engineer. Tolerances are defined as tolerances and are to be distinguished from irregularities in finish as described herein. The classes of finish and the requirements for finishing of concrete surfaces shall be generally specified in this sub-sections and as indicated on the Drawings. Finishing of concrete surfaces shall be performed only by workmen who are skilled concrete finishers.

The Contractor shall keep the Engineer informed as to when finishing of concrete will be performed. Unless inspection is waived in each specific case, finishing of concrete shall be performed only in the presence of the Engineer. Concrete surfaces will be tested by the Engineer where necessary to determine whether surface irregularities are within the limits hereinafter specified. Surface irregularities are classified as abrupt or gradual. Off-sets caused by displaced or misplaced form sheathing or lining or form sections, or otherwise defective form lumber will be considered as abrupt irregularities, and will be tested by direct measurements. All other irregularities will be considered as gradual irregularities/ and will be tested by the use of a template, consisting of a straight edge or the equivalent thereof for curved surfaces. The length of the template will be 1.5 meters.

The classes of finish for concrete surfaces shall be as shown on the Drawings or as directed by the Engineer. Interior surfaces shall be sloped for drainage where shown on the Drawings or directed. Surfaces which will be exposed to the weather shall be sloped for drainage. Unless the use of other slopes or level surfaces is indicated on the Drawings or directed. Surfaces which will be exposed to the weather shall be sloped for drainage. Unless the use of other slopes or level surfaces is indicated on the Drawings or directed, narrow surfaces, such as tops of walls shall be sloped approximately 10 mm per 30 cm. No grinding will be required on such formed surfaces other than that necessary for repair of surface imperfections as specified herein.

5.24 POLYVINYL CHLORIDE WATER STOP

5.24.1 Scope

The work to be done under this item consists of providing and installing PVC water stops as shown on the Drawings or as directed by the Engineer.

5.24.2 General

Polyvinylchloride waterstops shall be extruded from an elastomeric plastic compound, the basic resin of which shall be polyvinyl chloride (PVC). The compound shall contain such additional resins, plasticizers, stabilizers or other materials needed to ensure that when the material is compounded and extruded to the shapes and dimensions shown, it will have physical characteristics when tested by the U.S. Corps of Engineers Test Method specified below:

Physical Characteristics	No. of Specimens Tested	Requirement	USACE Test Method
Tensile strength using die III, not less than	5	12 N/Sq.mm (1750 psi)	568
Ultimate elongation using die III, not less than	5	350%	573
Low temperature brittleness, no sign of failure such as	5	-37°C	570
Stiffness in flexure, 13 mm span, not less than	3	2.75 N/sq.mm (400 psi)	571

5.24.3 Installation

Installation of waterstops shall be in accordance with the provision of AC1 504 R. The PVC Water stops shall be laid in continuous lengths. Splices in the continuity or at the intersections of runs of PVC water stops shall be performed by heat sealing the adjacent surfaces in accordance with the manufacturer's recommendations or as directed by the Engineer. A thermostatically controlled electric source of heat shall be used to make all splices. The correct temperature at which splices should be made will differ with the material used but should be sufficient to melt but not char the plastic. After splicing, a remoulding iron with ribs and corrugations to match the pattern of the water stop shall be used to reform the ribs at the splice. The continuity of the characteristics components of the cross-section of the water stop design (ribs, tubular center axis, protrusions, and the like) shall be maintained across the splice.

5.25 ADMIXTURES**5.25.1 General**

Admixtures, including air-entraining admixtures, foaming chemicals and water-reducing admixtures, shall not be used except with the prior approval of the Engineer. All tests for the evaluation and approval of an admixture shall be made by the Contractor at his cost.

5.25.2 Air-Entraining Admixtures

The source and brand of air-entraining admixture, required shall be proposed by the Contractor and approved by the Engineer. The air entraining admixture will be an approved substance or compound conforming to the requirements of ASTM C260-77, "Standard Specifications for Air-Entraining Admixtures for Concrete," which will produce entrained air in the concrete as hereinafter specified. The air-entraining admixture shall be added to the batch in solution in a portion of the mixing water. This solution shall be batched by means or a mechanical batcher capable of accurate measurement and in such a manner as to ensure uniform distribution of the admixture throughout the batch during the specified mixing period.

5.25.3 Water-Reducing Admixtures

The source, brand, types of suitable water reducing cement dispersing admixtures, if required, shall be proposed by the Contractor and approved by the Engineer. The water entraining admixture will be compatible with the air entraining admixture specified above and shall be batched and added to the concrete in the manner specified for the adding of air-entraining admixture but separate from the portion of the mixing water containing the air-entraining admixture. The quantities of water-reducing, cement dispersing admixture to be used shall be in accordance with the instructions of the Manufacturers as approved by the Engineer. Water reducing admixture shall conform to the requirements of ASTM C494-81 "Standard Specification for Chemical Admixtures for Concrete".

5.25.4 Foaming Chemicals

The source, brand and types of suitable foaming chemicals, if required, shall be as approved by the Engineer. The foaming agent shall conform to ASTM C869 "Standard Specifications for Foaming Agents used in Making Preformed Foam for Cellular Concrete."

5.26 EXPANSION JOINTS**5.26.1 Material**

Expansion joint material shall be pre-moulded asphalt impregnated fiber board, to be applied over the full joint width, except otherwise indicated on the drawings and shall conform to ASTM D1751-83.

5.26.2 Filler

Expansion joint filler shall consist of sponge rubber, self expanding cork or any other material and type as designated by ASTM D1752-84.

5.27 STEEL REINFORCEMENT**5.27.1 Scope**

The work to be done under these items shall include furnishing, cutting, bending, and placing all steel reinforcement as indicated on the Drawings or otherwise required. All reinforcement when surrounding concrete is placed, shall be free from loose, flaky rust, and scale, and free from oil, grease or other coating which might destroy or reduce its bond with the concrete. All placing shall be in accordance with Drawings furnished or approved. The use of reinforcement for the transmission of current for welding will not be permitted. All reinforcement, including dowels, remaining exposed in the work shall be suitably protected until embedded in concrete.

5.27.2 Cutting and Bending

Steel reinforcement may be mill or field cut and bent. All bending shall be in accordance with standard approved practice and by approved machine methods. When bending is required, it shall be performed prior embedding the bars in the concrete. In all such cases, the bars shall be cold bent. Bending or straightening of bars partially embedded in set concrete shall not be permitted except in isolated cases where corrective action or a field change is required and is specifically approved by the Engineer.

5.27.3 Quality

Concrete reinforcement bars shall be of following quality:

Intermediate grade Steel:

It shall be deformed bar conforming to ASTM 615-86 grade 40 and 60 or equivalent having minimum yield strengths of 40 ksi and 60 ksi respectively. The Contractor shall provide labour, materials, arrange measuring and testing facilities to ascertain quality, weight or quantity of steel at his own expense. No steel shall be incorporated in the Works without prior approval of the Engineer.

5.27.4 Spacing of Bars

The spacing of bars shall be as shown on the Drawings or as directed by the

Engineer. The variation from indicated spacing, provided that the total area of reinforcement is in accordance with the Drawings, shall not be more than 25 mm (1 inch).

5.27.5 Relation of Bars to Concrete Surface

The cover of all main reinforcement shall conform to the dimensions shown on the Drawings. The protective covering shall not be less than, and shall not exceed more than 6 mm from the values specified on the Drawings to indicate the clear distance from the edge of the main reinforcement to the concrete surface. The concrete covering of stirrups spacer bars and similar secondary reinforcement may be reduced by the diameter of such bars.

5.27.6 Splicing

Except as otherwise shown on the Drawings or specified herein, all splices, lengths of laps, splice locations, placement and embedment of latest reinforcement shall conform to the applicable requirements of American Concrete Institute 318-83, Building Code Requirements for Reinforcement Concrete. All splices and locations of laps in reinforcement shall be as shown on the Drawings or as directed by the Engineer. Additional bar splices shall be provided as required, subject to approval of the Engineer. Lapped ends of bars may be placed in contact and securely wired or may be separated sufficiently to permit the embedment of the entire surface of each bars by butt-welding or by approved mechanical methods such as the Cadweld splice or other type splice using positive connectors where indicated or directed by the Engineer. Butt welding of reinforcing bars, where indicated or directed shall conform to the requirements of American Welding Society's Recommended Practice for Welding Reinforcing Steel Metal Inserts and Connections. Concrete shall be protected from heat during welding operations.

5.27.7 Supports

All reinforcement shall be secured in place by use of metal or concrete supports, spacers, or ties, as approved by the Engineer. Such supports shall be of sufficient strength as to maintain the reinforcement in place throughout the concreting operation. The supports shall be used in such a manner that they will prevent discoloration or deterioration of the concrete. Concrete supports shall be manufactured of the same concrete mix as used in the structure to be concreted.

5.28 ANCHORS IN SPILLWAY FLOOR SLABS

The Spillway floor slabs shall be anchored into underlying bedrock in the areas shown on the Drawings. Holes drilled for anchor bars shall be kept plugged until just prior to commencement of grouting operation. Immediately before setting the anchor bars, each hole shall be thoroughly flushed with water and cleaned with compressed air to remove all water. Grouting of anchor bars shall be completed not less than six days in advance of related concreting

operations.

The anchors shall consist of reinforcing steel as shown on the Drawings. The grout shall be a cement grout designed to provide the greatest possible bond with the bedrock and the reinforcing steel.

The bars after, installation, shall be protected in such a manner as to prevent any movement until the grout is hardened.

5.29 MEASUREMENT AND PAYMENT

Measurement and payment for concrete, reinforcement steel and precast concrete will be made in accordance with the provisions of this clause specified hereinafter.

5.29.1 Method of Measurement

Concrete will be measured for the number of unit cubic meter of different grades acceptably placed complete in all respects as per Drawings and in strict accordance with this section of Specification.

Pre-cast members will be measured for the number of unit cubic meter acceptably cast, placed complete in all respects as per Drawings and as directed by the Engineer.

Measurement will be made for the tons (2240 lbs) of reinforcing steel acceptably placed on the basis of the lengths of bars installed in accordance with the approved Drawings or bar schedules or as directed, converted to weight for the "size of bars listed by the use of unit weights per linear meter as follows:

Bar Size	Unit Weight Kg/m	Unit Weight lbs/ft
6 mm	0.249	0.167
9 mm	0.560	0.376
13 mm	0.994	0.668
15 mm	1.552	1.043
18 mm	2.235	1.502
21 mm	3.042	2.044
25 mm	3.973	2.670
28 mm	5.059	3.775
31 mm	6.403	4.172
34 mm	7.906	5.049

Steel in laps and embedment indicated on the Drawings or as required by the Engineer will be paid for at the steel unit price. No measurement for payment will be made for the steel consumed in providing supports and for the additional steel in

laps which are authorized for the convenience of the Contractor.

Measurement for holes and grout for dowel - anchors will be based on the number of linear meter of hole drilled to the lengths shown on the drawings or as approved or directed by the Engineer. No measurement will be made for dowel or anchor holes drilled solely to accommodate the Contractor's construction procedure. The dowels will be measured as reinforcing steel.

Measurement will be made of the number of unit square meter of trash rack and weir blades of 12 gauge steel plate provided and acceptably fixed at the specified locations as shown on the drawings.

Measurement will be made of the number of mild steel plates with standard markings, steel flumes and M.S. shutter plates provided and acceptably fixed as specified on the Drawings and as directed by the Engineer.

Measurement will be made on lump sum basis for providing and installing vertical slide gates of sizes specified in the Bill of Quantities and details shown on the Drawings, and as directed by the Engineer.

5.29.2 Basis of Payment

Payment will be made in accordance with the unit prices in the Bill of Quantities for the various items in accordance with the Specifications and shall constitute full compensation for furnishing all materials, casting, fixing, installing, splicing, shuttering, drilling, grouting, equipment and labour and for performing all operations necessary to complete the work.

5.30 CODES AND STANDARDS

The work shall conform to the requirements of the following codes and Standards, unless otherwise specified.

*PS	419	Properties and Specifications of Blocks
ASTM	C31-87	Practices for Making and Curing Concrete Test Specimens in the Field.
ASTM	C33-86	Standard Specification for Concrete Aggregates.
ASTM	C39-86	Standard Test Methods for Compressive Strength of Cylindrical Concrete Specimens.
ASTM	C42-84a	Standard Methods of Obtaining and Testing Drilling Cores and Sawed Beams of Concrete.
ASTM	C78-84	Standard Test Methods of Test for Flexural strength of Concrete (using Simple Beam with Third Point Loading)
ASTM	C136-84a	Standard Method of Test for Sieve or Screen Analysis of Fine and Coarse Aggregates.
ASTM	C143-78	Standard Method of Test for Slump of Portland cement Concrete.
ASTM	C150-86	Standard specifications for Portland Cement.

ASTM	C404-85	Standard Specifications for Aggregate for Masonry Grout.
ASTM	C566-84	Standard Test Method for Total Moisture Content of Aggregate by Drying.
ASTM	D596-83	Methods of Reporting Results of Water Analysis
ASTM	A615-86	Standard Specifications for Deformed and Plain Billet – Steel Bars for Concrete Reinforcement.
ASTM	D1190-80	Standard Specifications for Concrete Joint Sealer, Hot Poured Elastic Types.
ASTM	D1751-83	Standard Specifications for Preformed Joint Fillers for concrete paving and Structural Construction (Non-extruding and Resilient Bituminous types)
ASTM	D1752-84	Standard Specifications for Preformed Sponge Rubber and Cork Expansion Joint Fillers for Concrete Paving and Structural Construction.
ASTM	D185-79	Standard Specifications for Concrete Joint sealer, Cold – Application Type.
BS	12-78	Specifications for ordinary and Rapid hardening Portland Cement.
BS	146-58	Specifications for Portland-blast furnace cement.
BS	3148-80	Methods of Tests for water for Making Concrete.
BS	4027-80	Specifications for sulphate Resisting Cement.
ACI	301-84 (Revised 1985)	Specifications for structural concrete for buildings.
ACI	304R-85	Guide for Measuring, mixing, transporting and placing concrete.
ACI	308-81 (Revised 1986)	Standard Practice for curing of concrete.
ACI	309-72 (Revised 1982)	Standard practice for Consolidation of Concrete.
ACI	316R-82	Recommendation for construction of concrete pavements and concrete bases.
ACI	318-89 & 318R-89	Building Code Requirements for Reinforced concrete and Commentary by ACI
ACI	318.1-89	Building Code Requirements for structural Plain Concrete.
ACI	318.1R-89	Commentary by ACI
ACI	347-78 (Re-approved 1984)	Recommended Practice for Concrete Formwork.

*PS -PAKISTAN STANDARDS

*BS -BRITISH STANDARDS

SECTION – 6

BRICK WORK

6.1 SCOPE

This section consists of construction of brick-walls of any thickness with first class hand-mould and/or machine pressed bricks with the specified ratio of cement mortar in foundation, plinth, super structure or for any other structure as directed by the Engineer, or shown in the Bid Schedule. The Contractor shall furnish all materials and all other requirements to produce finished brick work. Brick work and materials for brick work shall be in strict accordance with this section of the specifications and applicable drawings and subject to the terms and conditions of the Contract.

6.2 MATERIALS

6.2.1 Bricks

The bricks used shall be of standard size (9"x4.5"x3") first class well burnt, uniform in shape, size, texture, colour and should produce a ringing sound when struck. The bricks shall be free from flaws, cracks, chips, stone nodules of lime or kankar or any other blemishes. The brick shall not absorb more than one sixth of its weight when soaked in water for one hour. Compressive strength shall not be less than 2000 lbs per square inch, Bricks over burnt, under burnt vitrified and irregular shall not to be used. Bricks of uniform size shall be used throughout the work and source shall not be diversified.

6.2.2 Portland Cement

Portland cement shall conform to the stipulations and requirements set forth in Section for "Plan and Reinforced Concrete".

6.2.3 Mortar Sand

Sand for mortar used in construction of brickwork required under these Specifications shall be furnished by the Contractor in accordance with the provisions and in conformity with the stipulations and requirements of ASTM Designation C144-70 or latest revision and shall have a fineness modulus between 1.6 and 2.5.

6.2.4 Water

The water used in the preparation of mortar shall be free from objectionable quantities of silt, organic matter, alkali salts and other impurities and it will be tested and approved by the Engineer at the Contractor's cost.

6.3 MORTAR COMPOSITION

Mortar for all brickwork requiring mortar shall, except when otherwise specified by these Specifications or as directed by the Engineer, consist of one part of Portland cement to 3 parts of damp loose mortar sand by volume and sufficient water to produce the proper consistence for the intended use. Mortar shall not be retained for more than 30 minutes and shall be constantly worked over with hoc or shovel until used.

6.4 MORTAR BATCHING

Methods or equipment used for mixing mortar shall be such as will accurately determine and control the amount of each separate ingredient entering into the mortar and shall be subject to the approval of the Engineer. If a mixer is used it shall be of approved design and the mixing time after the ingredients are in the mixer, except for the full amount of water, shall not be less

than two minutes.

Mortar shall be mixed only in sufficient quantities for immediate use and all mortar not used within 30 minutes after addition of water to the mix shall be wasted. Retempering of mortar shall not be allowed. Mixing pans and troughs shall be thoroughly cleaned and washed at the end of each day's work.

6.5 SOAKING

Before use all bricks shall be soaked in clean water in tanks or pits for at least two hours.

6.6 LAYING OF BRICKS

All brickwork shall be skillfully laid with level courses, uniform joints, square corners, plumb verticals and true surfaces except when otherwise shown on the Drawings or directed by the Engineer. Brickwork will be of best standard of workmanship obtainable and objectionable offsets in the brickwork shall be avoided. Smoothest practicable finished surface of the brickwork shall be ensured. Unless otherwise specified, bricks shall be laid in English Bond with frogs (Manufacturer's marks) upward.

All horizontal joints shall be parallel and truly level. Vertical joints in alternate courses shall come directly over one another. Thickness of joints unless otherwise specified shall not be less than $\frac{1}{4}$ of an inch and not more than $\frac{3}{8}$ of an inch. The height of 4 courses and 3 joints as laid shall not exceed by *more* than 1 inch the height of 4 bricks as piled one upon the other.

6.7 CURING

All brickwork involving use of cement shall be cured by water curing or other acceptable methods. The Engineer shall approve all methods and operations of the Contractor in curing different portions of work.

When curing by water, brickwork shall be kept wet for at least ten days by covering with water saturated materials or by a system of perforated pipes, mechanical sprinklers, porous hose, ponding or by any other approved method which will keep all surfaces to be cured continuously wet. Water used for curing shall meet the requirements Clause 7.2.4 of these specifications.

6.8 MEASUREMENT AND PAYMENT

6.8.1 Method of Measurement

Measurement for brickwork shall be in unit cubic meter of brick work provided within the limits as shown on the Drawings or as directed by the Engineer.

6.8.2 Basis of Payment

Payment for brickwork shall be made at the contract unit price for unit cubic meter. Payment shall constitute full compensation for furnishing all materials, equipment and labor including all incidentals necessary to complete the work.

SECTION – 7

REINFORCED CEMENT CONCRETE PIPE

7.1 SCOPE OF WORK

The work to be done under this section consists of furnishing, laying, jointing and testing pre-cast RCC Pipe Line in the excavated trenches on the bedding material for conveyance of water complete in all respects as shown on the Drawings and elsewhere and as directed by the Engineer.

7.2 GENERAL

- 1) All RCC Pipe shall be furnished and installed in complete conformity with the stipulations and requirements specified herein and elsewhere in these specifications and on the Drawings.
- 2) All excavation required in placing RCC Pipe under these specifications shall be performed by the Contractor in accordance with the provisions of, and in complete conformity with the stipulations and requirements specified in Section-2, "Excavation".

7.3 CLASSIFICATIONS

- 1) The RCC Pipe shall be manufactured in accordance with the Specifications of ASTM C-361 or as specified on the drawing of internal dia.

7.4 MATERIALS

- 1) All materials, methods of manufacture and strength requirements for the RCC Pipe shall conform to the requirements of ASTM Designation C-361 and shall be subject to inspection and approval of the Engineer.
- 2) Cement - Portland cement shall conform to the requirements of specifications set forth in Section for "Plain and Reinforced Concrete".
- 3) Sand - All sand shall conform to the Specifications for sand set forth in Section for "Plain and Reinforced Concrete".
- 4) Aggregates - Aggregates shall conform to ASTM Specification C-33 except that the requirements for gradation shall not apply.
- 5) Steel reinforcement - Reinforcement shall consist of wire conforming to ASTM Specification A-82 or A-496 or wire fabric conforming to Specifications A-185 or Specifications A-497 or bars of Grade 40 steel conforming to Specifications A-615 or bars of Grade 80 steel conforming to Specification A-306.

7.5 MIXTURE

The aggregate shall be so sized, graded, proportioned and thoroughly mixed in a batch mixer with such proportions of cement and water as will produce a homogeneous concrete mixture of such quality that pipe will conform to the classification specified above. In no case shall the proportion of Portland Cement in the mixture be less than six U.S. Standard bags (94 lbs) per cubic yard (56 kg/cu.m) of the concrete.

7.6 JOINTS

- 1) The ends of reinforced concrete pipe sections shall be so formed that when the pipes are laid together they will make a continuous and uniform line of pipe. The joints shall be such as will permit effective jointing and to permit placement without irregularities in the flow line. The joint shall be bell and spigot joint with rubber gasket of ½ inch thickness of inside diameter equal to the inside diameter of the concrete pipe and approved by the Engineer.

7.7 MANUFACTURE

- 1) Placement of Concrete - The transporting and placement of concrete shall be by methods that will prevent the segregation of the concrete materials and the displacement of the reinforcement steel from its proper position in the form.
- 2) Curing - Pipes shall be cured by any one of the following methods.
 - i) Steam Curing
 - ii) Water Curing

The pipe shall be cured for a sufficient length of time so that the concrete will develop the specified strength at 28 days or less.
- 3) Pipes shall be substantially free of fractures, large or deep cracks, and surface roughness. The ends of the pipe shall be normal to the walls and centre of the pipe.

7.8 TESTING AND INSPECTION

- 1) Pipe shall be tested by the method covered in the standard specifications ASTM Designations: C-76 and each manufacturer furnishing pipe under these specifications shall be fully equipped to carry out the test herein designated. Upon the demand of the Engineer and under his supervision, the manufacturer shall perform such number of tests as the Engineer may deem necessary to establish the quality of the pipe manufactured. Failure of any pipe to meet the test requirements shall be sufficient cause for rejection of all pipes which the test specimen represents. All pipes shall be subjected to inspection by the Engineer at the factory and point of delivery. The purpose of the inspection shall be to cull and reject pipes which independent of the physical tests herein specified, fail to meet the requirements of these specifications.

7.9 REJECTION

- (1) Rejection may be made on account of any of the following:
 - a) Fracture or cracks passing through the shell, except for a single end crack that does not exceed the depth of the joint.
 - b) Defects that indicate imperfect proportioning, mixing and molding.
 - c) Surface defects indicating honeycombed or open texture.
 - d) Damaged ends, where such damage would prevent the making of a satisfactory joint.
 - e) Failure to give a clear ringing sound when tapped with a light hammer.

- f) Exposure of the reinforcement where such exposure indicates that the reinforcement was misplaced.
- g) Pipe damaged during shipment or handling may be rejected even if previously approved.

7.10 REPAIR

Pipe may be repaired if necessary because of occasional imperfections in manufacture or accidental injury during handling and will be acceptable if in the opinion of the Engineer, the repairs are sound, properly finished, cured and the repaired pipe conforms to the requirements of these specifications.

7.11 INSTALLATION

- 1) All concrete pipes shall be set to the alignment and grades shown on the Drawings or established by the Engineer. Concrete pipe installed in the ground shall be laid on a compact and properly shaped bedding material of natural gravel or crushed rock as per specifications in Section for "Construction of Earthfill" and approved by the Engineer, and compacted in such a manner as will not disturb the alignment or grade of the pipe. Payment for natural gravel or crushed rock shall be made under "Bedding Material". Concrete pipe installed in concrete or masonry structures shall be secured, in a manner satisfactory to the Engineer, against any misalignment during concrete or masonry placement.
- 2) The Contractor shall furnish all materials required and shall construct water-tight joints between concrete pipe sections. Ends of pipe sections shall be thoroughly cleaned and the section being placed drawn up tightly to correct line and grade. Mortar for finishing joints in concrete pipe shall consist of one part Portland cement to three parts sand by volume with sufficient water to obtain a suitable consistency. All operations of the Contractor in jointing the pipe sections shall be approved by the Engineer.

7.12 MEASUREMENT AND PAYMENT

7.12.1 Reinforced Cement Concrete Pipe

Measurement for payment for reinforced cement concrete pipe will be made of the number of linear meters of pre-cast concrete pipe of each size actually furnished and installed as shown on the Drawings or directed by the Engineer, measured along the centre line of the pipe from end to end of the pipe in place without allowance for laps at joints or for excess material which may be trimmed off to fit the required installation.

No direct payment will be made for cement and reinforcement used in manufacturing of RCC Pipe and the cost of furnishing all materials required for manufacturing RCC Pipe shall be included in the unit rate tendered in the Bill of Quantities for the item of reinforced cement concrete pipe in which the materials are used.

Payment for furnishing and installing reinforced cement concrete pipe will be made for the number of linear meter of pipe acceptably installed at the contract unit price in the Bill of Quantities. The amount of bid for the item shall be full payment for the work specified herein and on the Drawings for Reinforced Cement Concrete Pipe, including spigots, socket ends, rubber ring and cement mortar for jointing concrete pipe installed complete in all respects and approved by the Engineer.

7.12.2 T-Joints and Control Valves for R.C.C Pipes

Measurement for payment will be made for the number of T-Joints and Control Valves of specified sizes provided and fixed according to the details given on Drawings and as directed by the Engineer.

Payment will be made for the number of T-Joints and Control Valves measured at the contract unit price and shall constitute full compensation for providing, fixing and all the related works in accordance with the Drawings and as directed by the Engineer.

DRAWING



PROJECT VICINITY MAP



KEY MAP

LEGEND

- INTERNATIONAL BOUNDARY
- PROVINCE BOUNDARY
- CAPITAL
- PROVINCE CAPITAL
- ROAD
- DAM SITE
- RIVERS

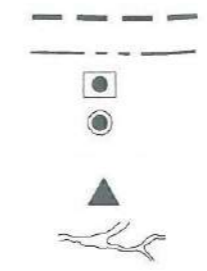

S.NO.	DATE	DESCRIPTIONS	CHECK
SMALL DAMS ORGANIZATION IRRIGATION DEPARTMENT			
SMALL DAM PROJECT			
SUMARI PAYAN DAM PROJECT LOCATION PLAN			
PAKISTAN ENGINEERING SERVICES (PVT.) LTD. 188 -Y, COMMERCIAL AREA, PHASE-III, D.H.A, LAHORE.			
DRAWN:	ZAHID RANA	DATE: JUNE 2009	REV. No.
DESIGNED:	M ANWAR KHAN	DRAWING NO.	
CHECKED:	ASFIANDYAR ALI KHAN	SPD-IRRI-1.1	
APPROVED:	SIBT UL HASSAN NAQVI		

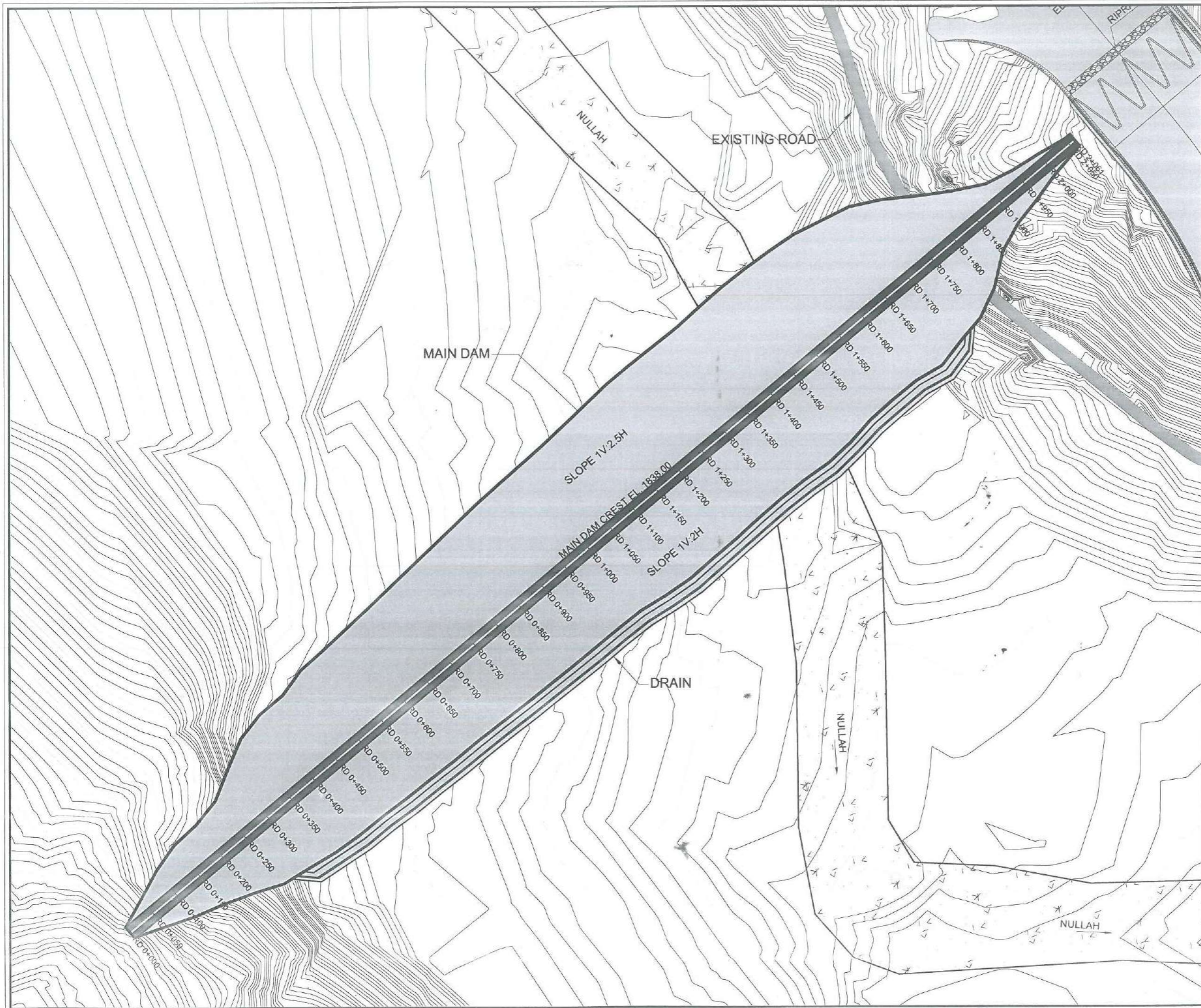

NOTES

ALL DIMENSIONS AND LEVELS ARE IN FEET.

SHEET 1 OF 2



S. NO.	DATE	DESCRIPTIONS	CHECK
		DIRECTORATE GENERAL SMALL DAMS IRRIGATION DEPARTMENT KHYBER PAKHTUNKHAWA	

SMALL DAM PROJECT

SUMARI PAYAN DAM PROJECT
DAM LAYOUT PLAN



PAKISTAN ENGINEERING SERVICES (PVT.) LTD.
7 - B, COMMERCIAL AREA, PHASE - V,
D.H.A, LAHORE.

DESIGNED BY:	FAROOQ ALI	DATE:	DEC-2023	REV. No:	
CHECKED BY:	AHMED SHAHZAWAR	DRAWING NO.:			
APPROVED BY:	ADNAN MANZOOR		D-03		0

Sr.No	Easting	Northing
1	9991687.214	3361309.401
2	9991737.425	3361327.249
3	9991788.268	3361344.341
4	9991836.186	3361364.941
5	9991886.23	3361382.991
6	9991938.075	3361398.879
7	9991981.057	3361425.402
8	9992024.37	3361451.529
9	9992065.29	3361480.528
10	9992104.25	3361511.879
11	9992144.319	3361541.899
12	9992183.518	3361572.962
13	9992223.041	3361603.637
14	9992261.576	3361635.497
15	9992300.983	3361666.312
16	9992340.623	3361696.846
17	9992379.94	3361727.768
18	9992419.256	3361758.691
19	9992458.117	3361790.161
20	9992496.818	3361821.821
21	9992536.08	3361852.809
22	9992579.217	3361879.148
23	9992620.61	3361907.579
24	9992696.25	3361973.016
25	9992733.113	3362006.882
26	9992770.956	3362039.574
27	9992810.065	3362070.745
28	9992851.109	3362099.595
29	9992887.877	3362133.576
30	9992921.499	3362171.332
31	9992958.696	3362204.798
32	9992997.204	3362236.692
33	9993041.054	3362262.173
34	9993072.411	3362302.648
35	9993105.401	3362341.163
36	9993128.857	3362391.117

Sr.No	Easting	Northing
37	9993143.176	3362452.038
38	9993169.212	3362498.897
39	9993201.099	3362538.735
40	9993231.184	3362580.737
41	9993264.282	3362619.122
42	9993271.771	3362627.676
43	9993255.766	3362646.882
44	9993247.12	3362639.716
45	9993203.079	3362614.462
46	9993160.309	3362587.684
47	9993114.377	3362564.7
48	9993058.92	3362553.146
49	9993000.649	3362544.969
50	9992940.654	3362538.861
51	9992885.373	3362527.097
52	9992839.267	3362504.321
53	9992793.162	3362481.545
54	9992751.531	3362453.4
55	9992711.091	3362423.825
56	9992671.604	3362393.108
57	9992634.108	3362359.999
58	9992597.051	3362326.366
59	9992557.744	3362295.432
60	9992518.506	3362264.415
61	9992479.781	3362232.783
62	9992443.401	3362198.336
63	9992407.127	3362163.762
64	9992370.429	3362129.697
65	9992332.984	3362096.529
66	9992295.523	3362063.379
67	9992258.259	3362029.993
68	9992222.097	3361995.286
69	9992185.888	3361960.634
70	9992149.615	3361926.059
71	9992113.417	3361891.394
72	9992077.03	3361856.956



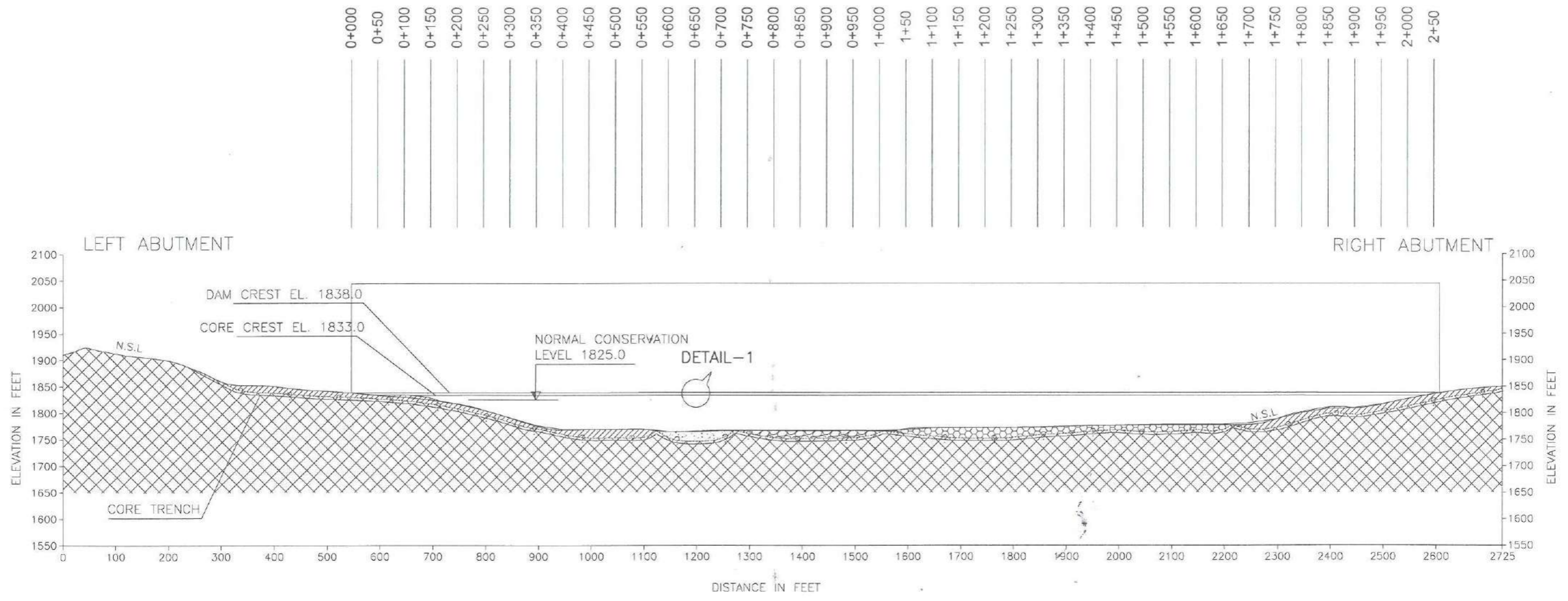

Sr.No	Easting	Northing
72	9992077.03	3361856.956
73	9992040.243	3361822.998
74	9992003.544	3361788.934
75	9991966.161	3361755.691
76	9991935.863	3361713.946
77	9991897.452	3361681.937
78	9991865.703	3361641.933
79	9991843.492	3361590.483
80	9991822.419	3361537.668
81	9991790.368	3361498.027
82	9991753.559	3361464.095
83	9991724.048	3361421.405
84	9991698.437	3361374.036
85	9991672.276	3361327.326

SHEET 2 OF 2

Sr.No	DATE	DESCRIPTIONS	CHECK
DIRECTORATE GENERAL SMALL DAMS IRRIGATION DEPARTMENT KHYBER PAKHTUNKHAWA			
SMALL DAM PROJECT			
SUMARI PAYAN DAM PROJECT DAM CORDINATES			
 PAKISTAN ENGINEERING SERVICES (PVT.) LTD. 7 - B, COMMERCIAL AREA, PHASE - V, D.H.A, LAHORE.			
DESIGNED BY:	FAROOQ ALI	DATE:	DEC-2023
DESIGNED BY:	AHMED SHAKZAWAR	DRAWING NO.	
CHECKED:	ASHFAQ ALI		
APPROVED:	ADNAN MANZOOR	D-03	0



LEGEND

-  STREAM BED DEPOSITS:
-  CULTIVATED LAND:
-  TALLUS AND SCREE:
-  SHALE: (UPPER SURFACE WEATHERED)
-  ALLUVIAL DEPOSIT:

NOTES

1. ALL LEVELS AND DIMENSIONS ARE IN FEET
2. FOR DEATILS OF X-SECTIONS SEE DRAWING NO. 5.2 AND 5.4
3. FOR GEOLOGICAL DETAILS SEE DRAWING NO. 3.4

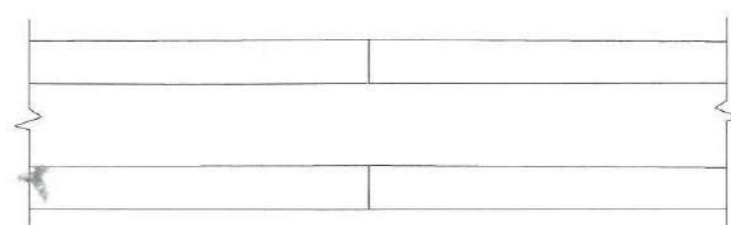

DETAIL-1
DAM CREST CAMBER,
1% OF MAX HT. (0.9675')

S.NO.	DATE	DESCRIPTIONS	CHECK
SMALL DAMS ORGANIZATION, IRRIGATION DEPARTMENT			
SMALL DAM PROJECT			
SUMARI PAYAN DAM L-SECTION ALONG DAM AXIS			
PAKISTAN ENGINEERING SERVICES (PVT.) LTD. 188 - Y, COMMERCIAL AREA, PHASE-II, D.H.A, LAHORE.			
DRAWN:	M. NADEEM	DATE: JUNE, 2009	REV. No.
DESIGNED:	ASAO	DRAWING NO.	
CHECKED:	ZAH-EER MALIK	5.5	
APPROVED:	SIBT-UL-HASSAN NAQVI		

NOTES

ALL DIMENSIONS AND LEVELS ARE IN FEET.

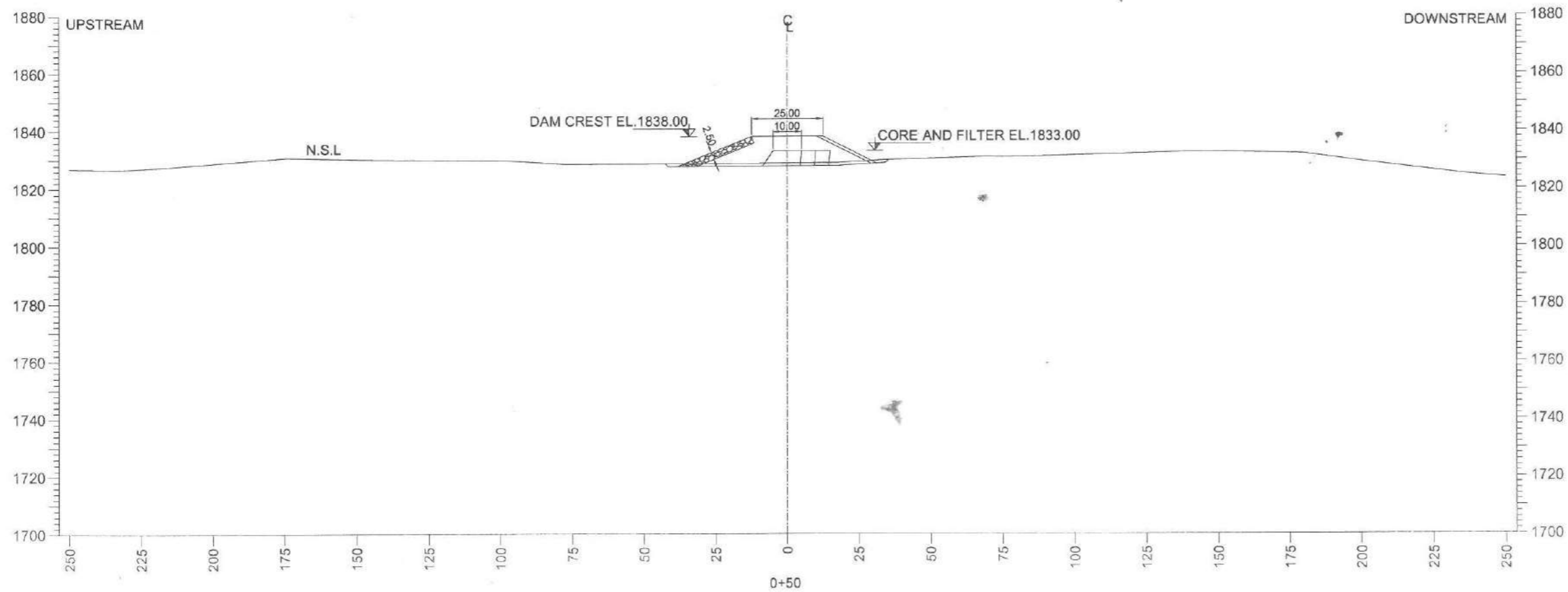
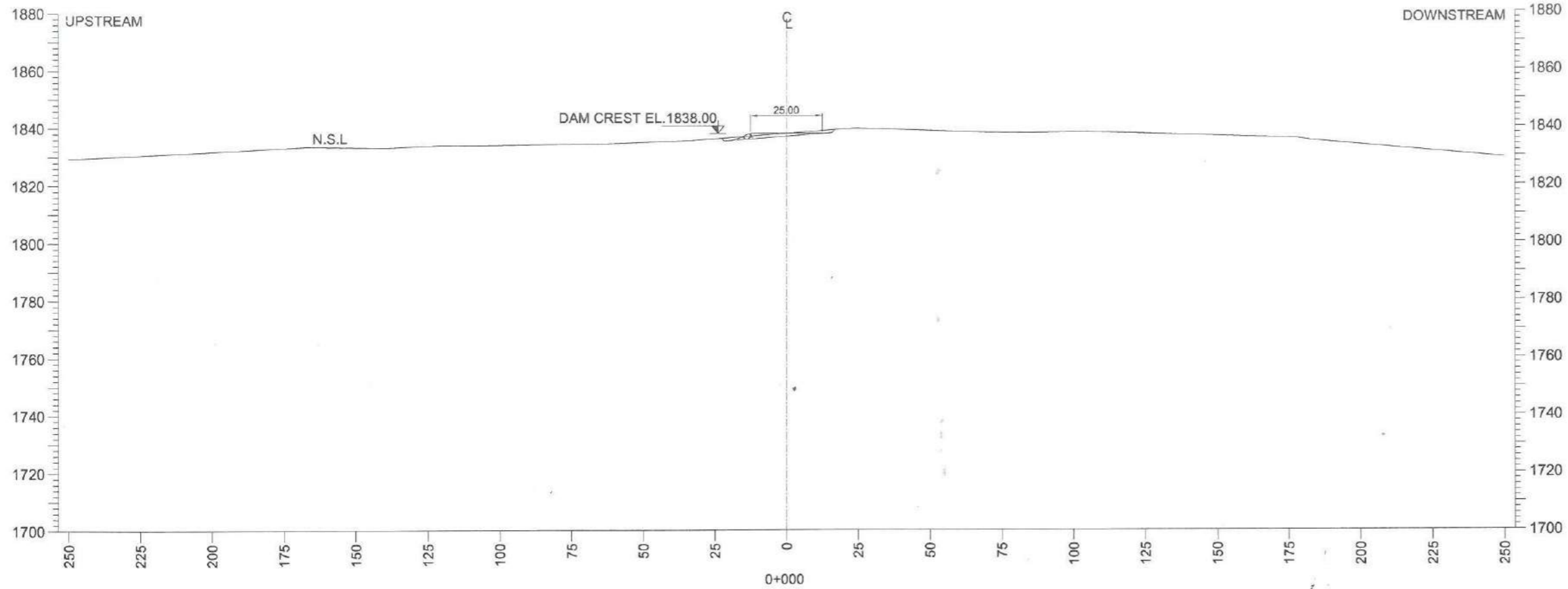

SHEET 1 OF 22



S. NO.	DATE	DESCRIPTIONS	CHECK
DIRECTORATE GENERAL SMALL DAMS IRRIGATION DEPARTMENT KHYBER PAKHTUNKHAWA			
SMALL DAM PROJECT			
SUMARI PAYAN DAM PROJECT DAM X-SECTIONS			
PAKISTAN ENGINEERING SERVICES (PVT.) LTD. 7 - B, COMMERCIAL AREA, PHASE - V, D.H.A, LAHORE.			
DESIGNED BY:	FAROOQ ALI	DATE:	DEC-2023
DESIGNED:	AHMED SHAHZAWAR	DRAWING NO.:	
CHECKED BY:	ASIF AD ALI		
APPROVED:	ADRIAN MANZOOR	D-03	0

NOTES

ALL DIMENSIONS AND LEVELS ARE IN FEET.

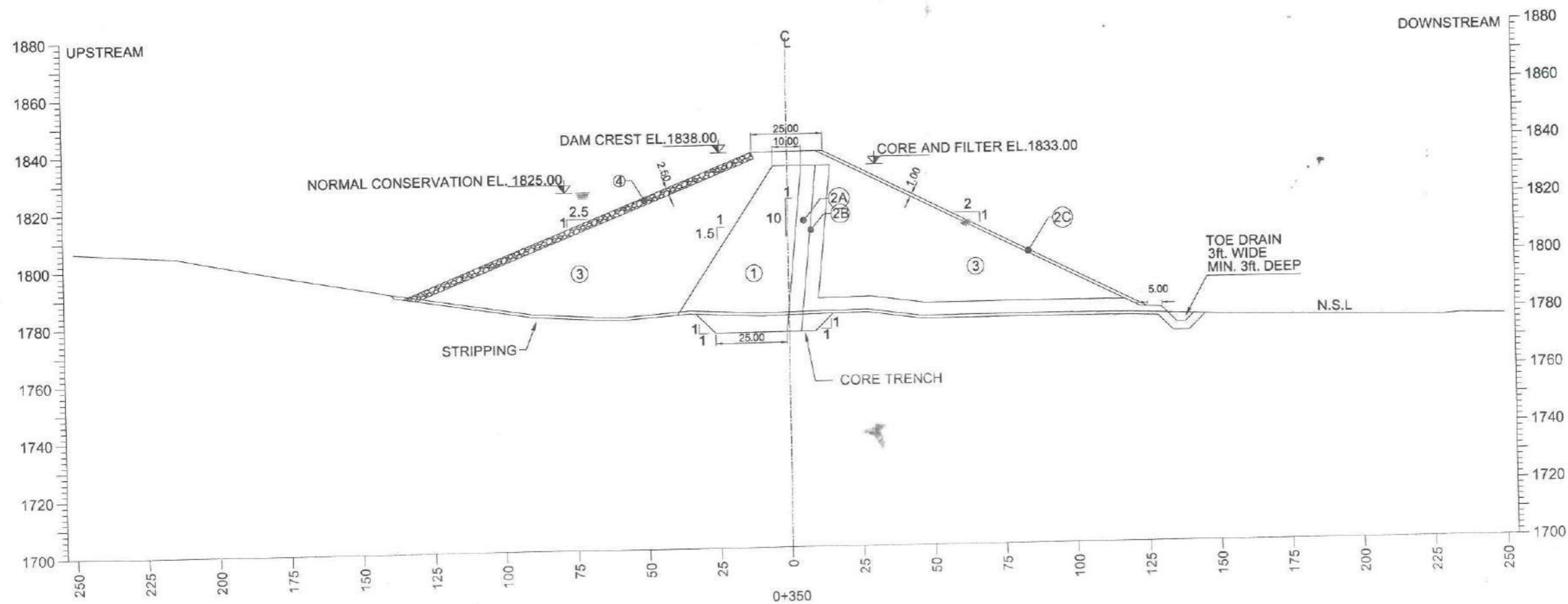
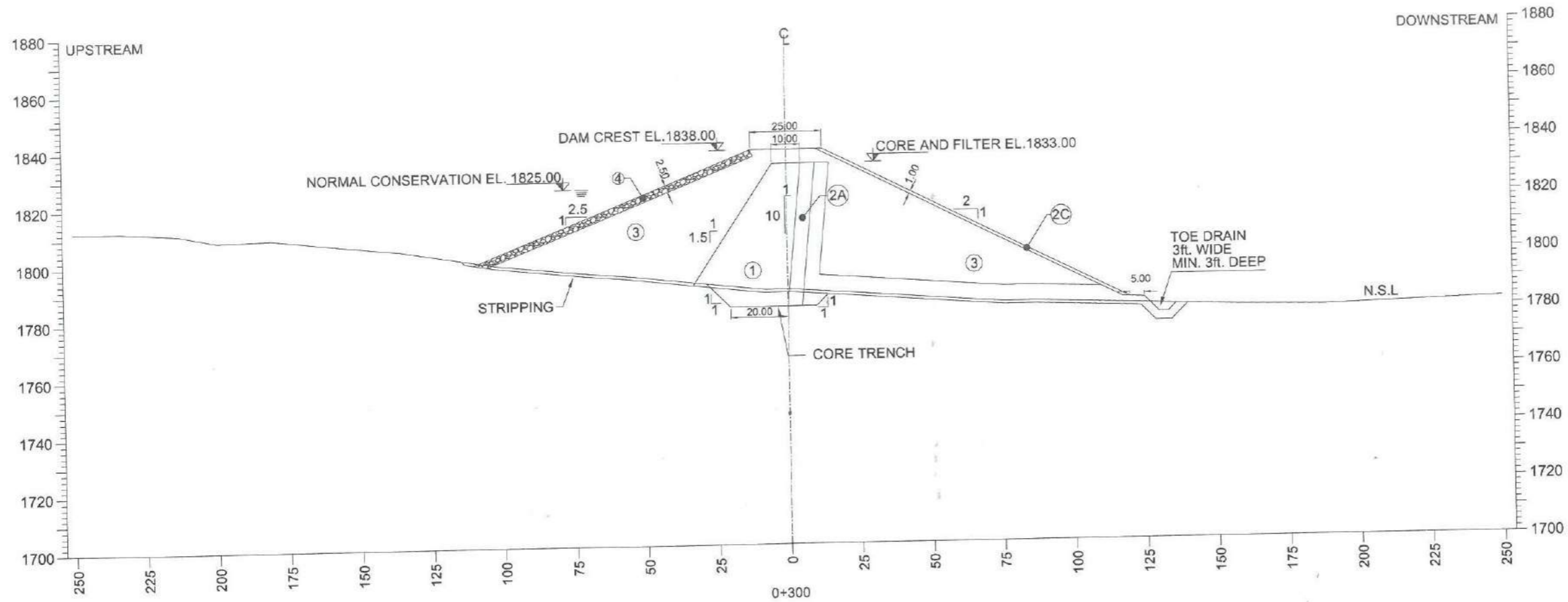

SHEET 4 OF 22



S.NO.	DATE	DESCRIPTIONS	CHECK
DIRECTORATE GENERAL SMALL DAMS IRRIGATION DEPARTMENT KHYBER PAKHTUNKHAWA			
SMALL DAM PROJECT			
SUMARI PAYAN DAM PROJECT DAM X-SECTIONS			
 PAKISTAN ENGINEERING SERVICES (PVT.) LTD. 7 - B, COMMERCIAL AREA, PHASE - V, D.H.A, LAHORE.			
DRAWN BY:	FAROOQ ALI	DATE:	DEC-2023
DESIGNED:	AHMED SHAHZANAR	DRAWING NO.	
CHECKED:	ASHFAQ ALI		D-03
APPROVED:	ADNAN MANZOOR	REV. No.	0

NOTES

ALL DIMENSIONS AND LEVELS ARE IN FEET.

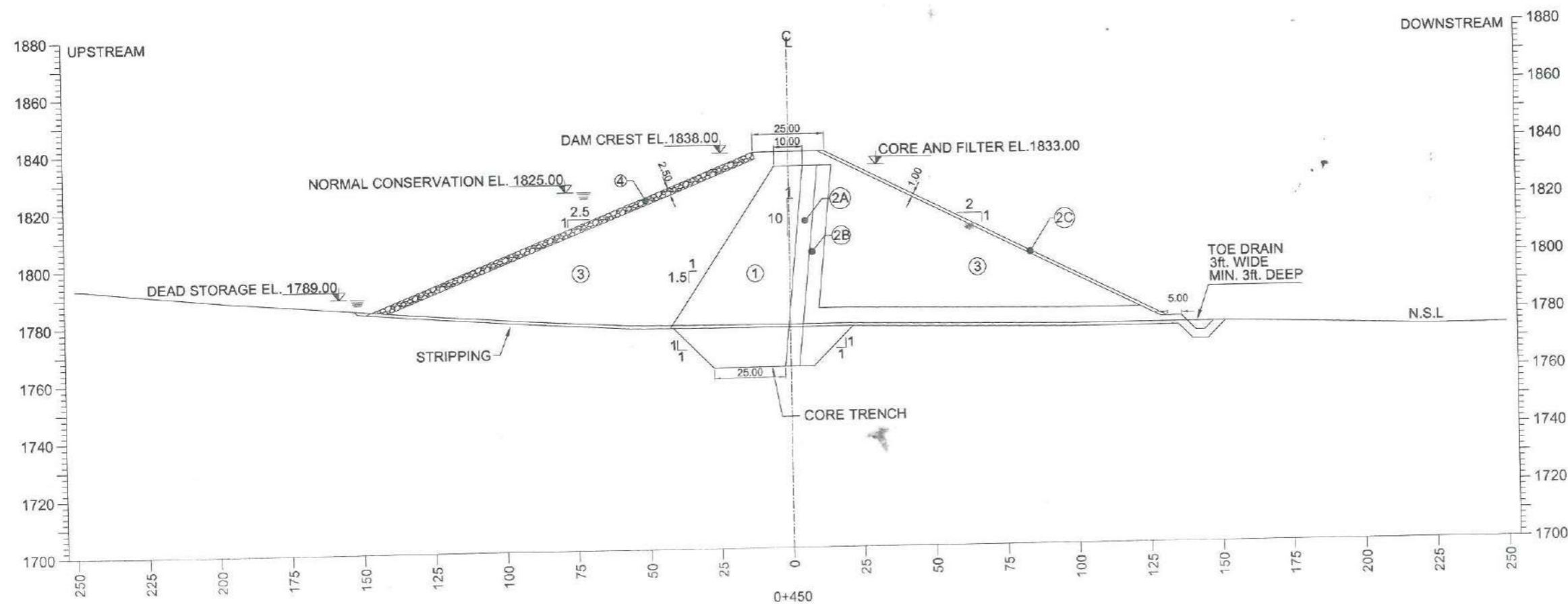
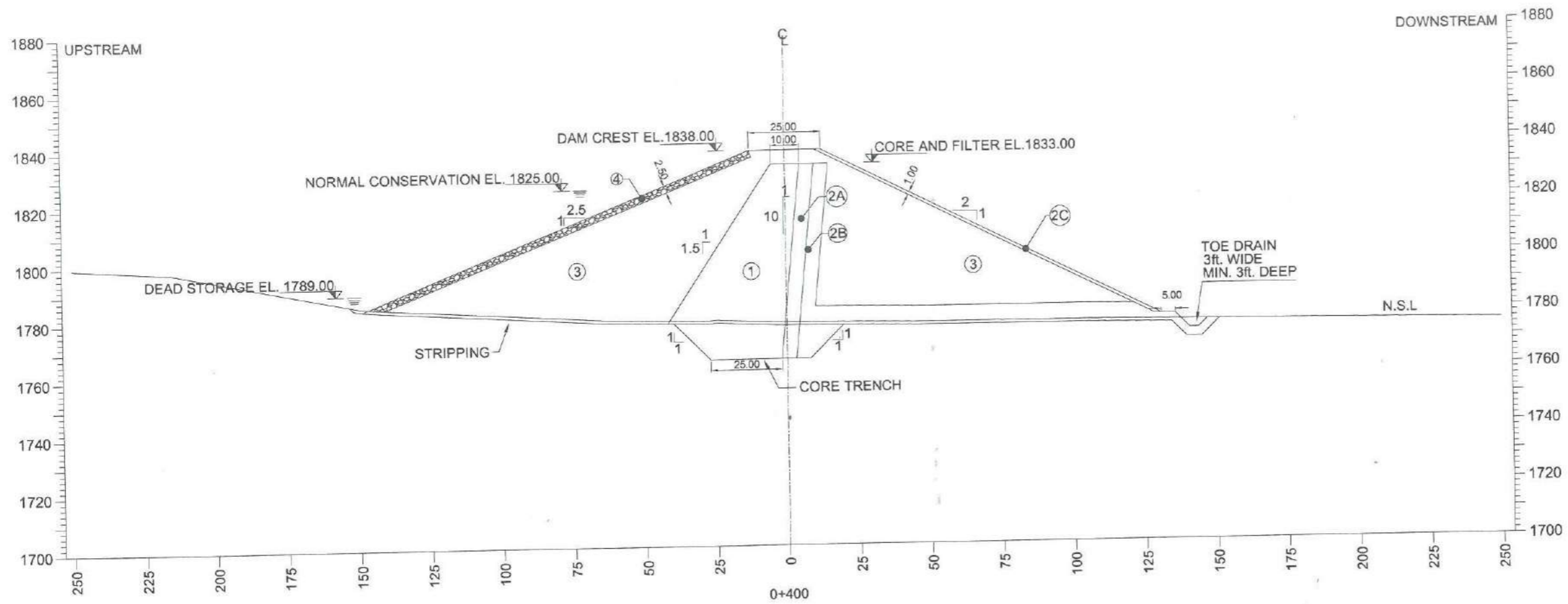

SHEET 5 OF 22



S. NO.	DATE	DESCRIPTIONS	CHECK
DIRECTORATE GENERAL SMALL DAMS IRRIGATION DEPARTMENT KHYBER PAKHTUNKHAWA			
SMALL DAM PROJECT			
SUMARI PAYAN DAM PROJECT DAM X-SECTIONS			
 PAKISTAN ENGINEERING SERVICES (PVT.) LTD. 7 - B, COMMERCIAL AREA, PHASE - V, D.H.A, LAHORE.			
DESIGNED BY:	FAROOQ ALI	DATE:	DEC-2023
DESIGNED:	ARMED SHAHZAWAR	DRAWING NO.	
CHECKED:	ASHFAQ ALI		D-03
APPROVED:	ADNAN MANZOOR		0

NOTES

ALL DIMENSIONS AND LEVELS ARE IN FEET.

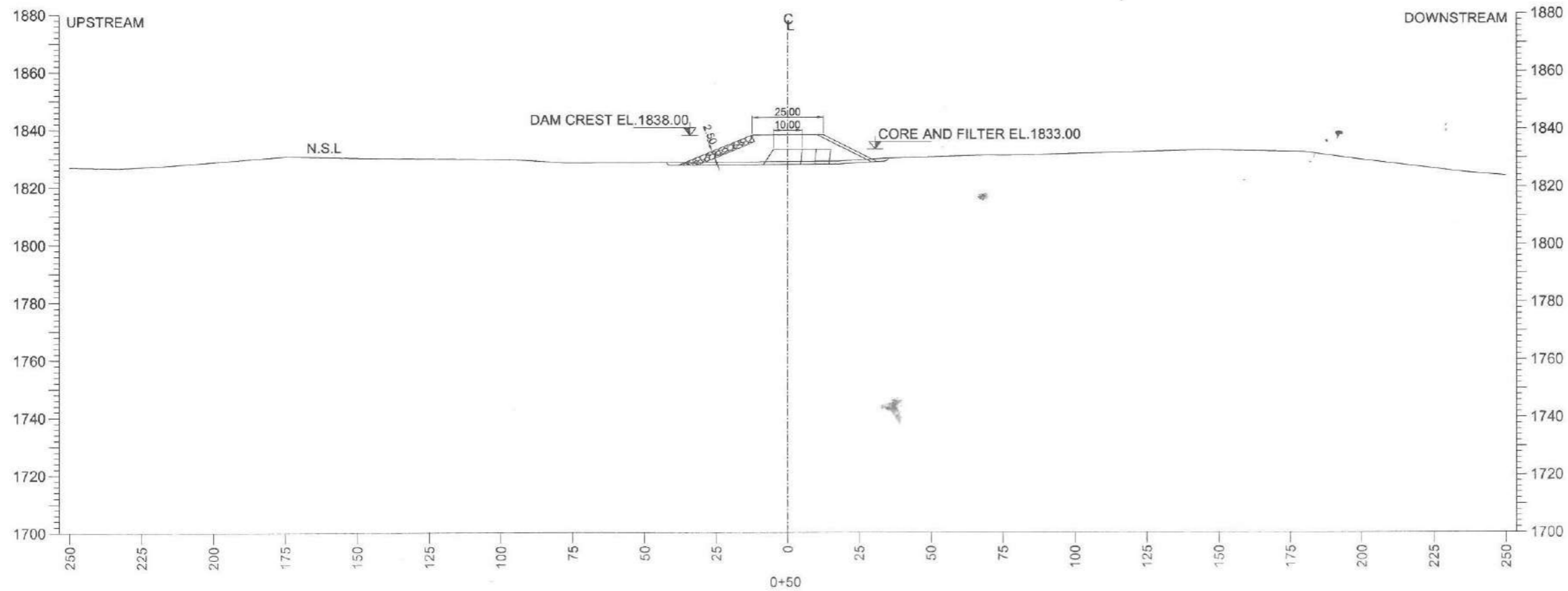
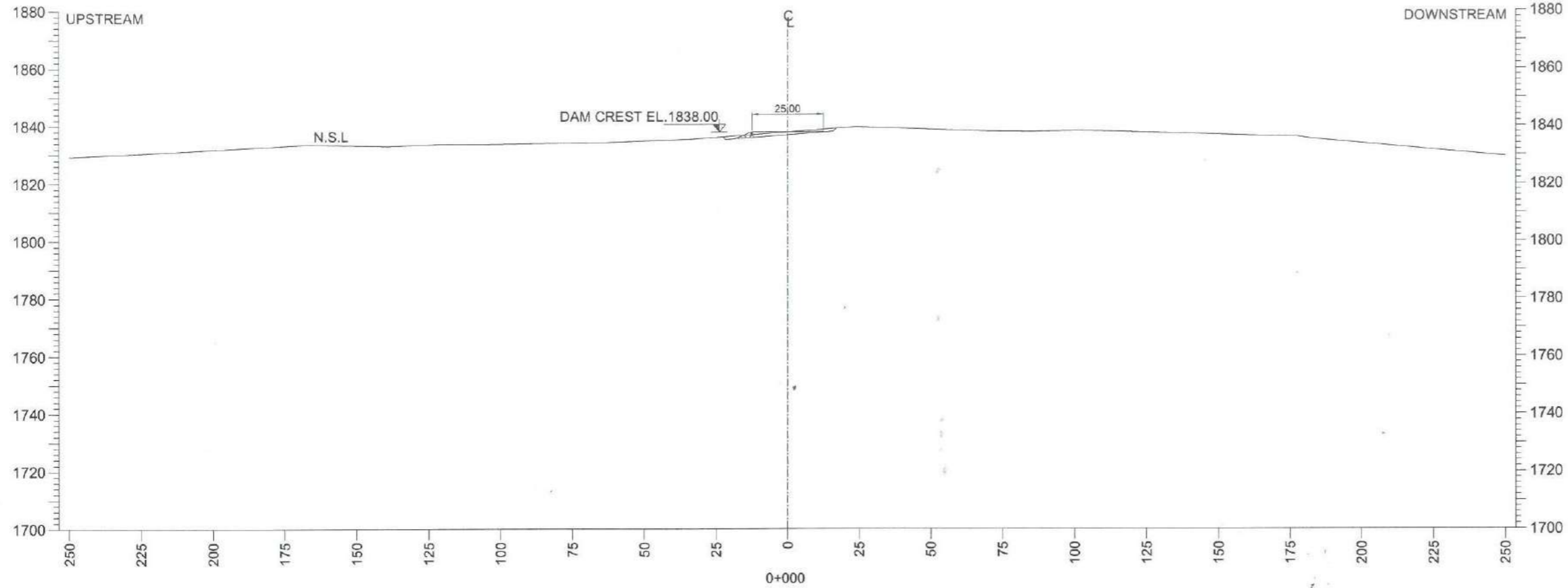

SHEET 1 OF 22



S.NO.	DATE	DESCRIPTIONS	CHECK
DIRECTORATE GENERAL SMALL DAMS IRRIGATION DEPARTMENT KHYBER PAKHTUNKHAWA			
SMALL DAM PROJECT			
SUMARI PAYAN DAM PROJECT DAM X-SECTIONS			
 PAKISTAN ENGINEERING SERVICES (PVT.) LTD. 7 - B, COMMERCIAL AREA, PHASE - V, D.H.A, LAHORE.			
DESIGNED BY:	FAROOQ ALI	DATE:	DEC-2023
DESIGNED:	AHMED SHAHZAIWAR	DRAWING NO.	
CHECKED:	ASHFAQ ALI		D-03
APPROVED:	ADNAN MANZOR		0

NOTES

ALL DIMENSIONS AND LEVELS ARE IN FEET.

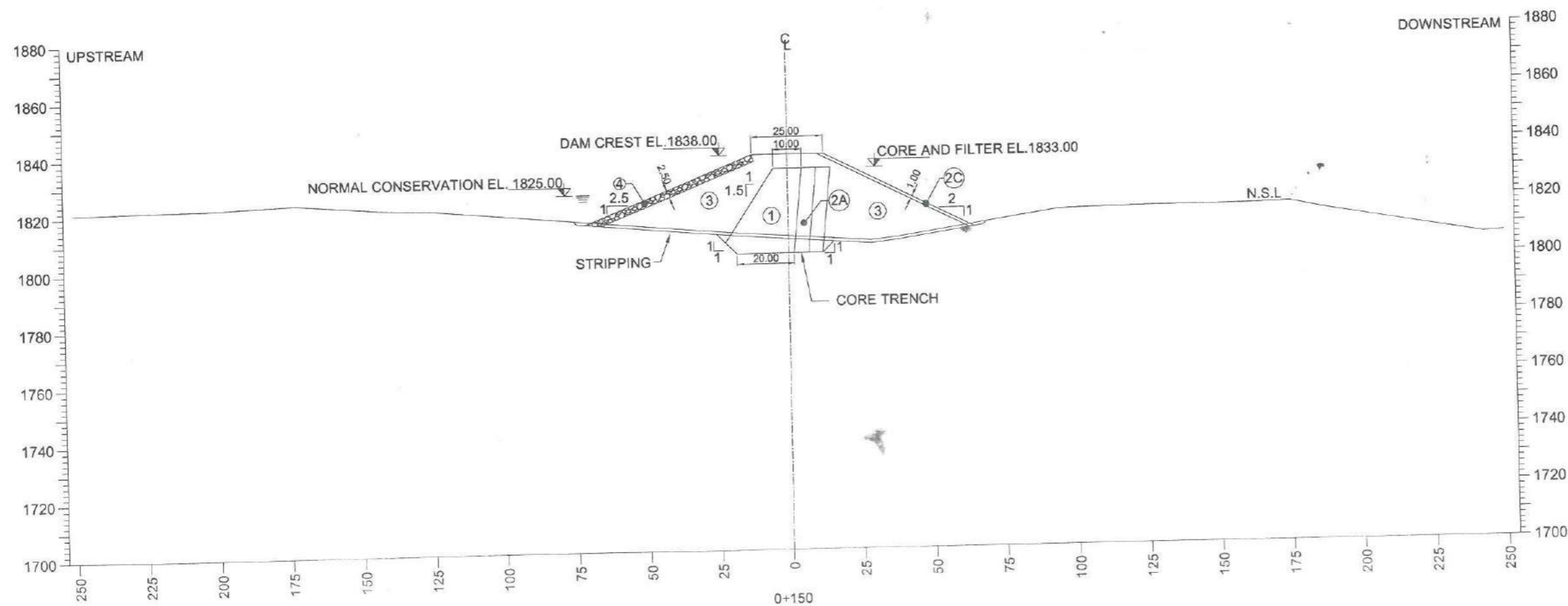
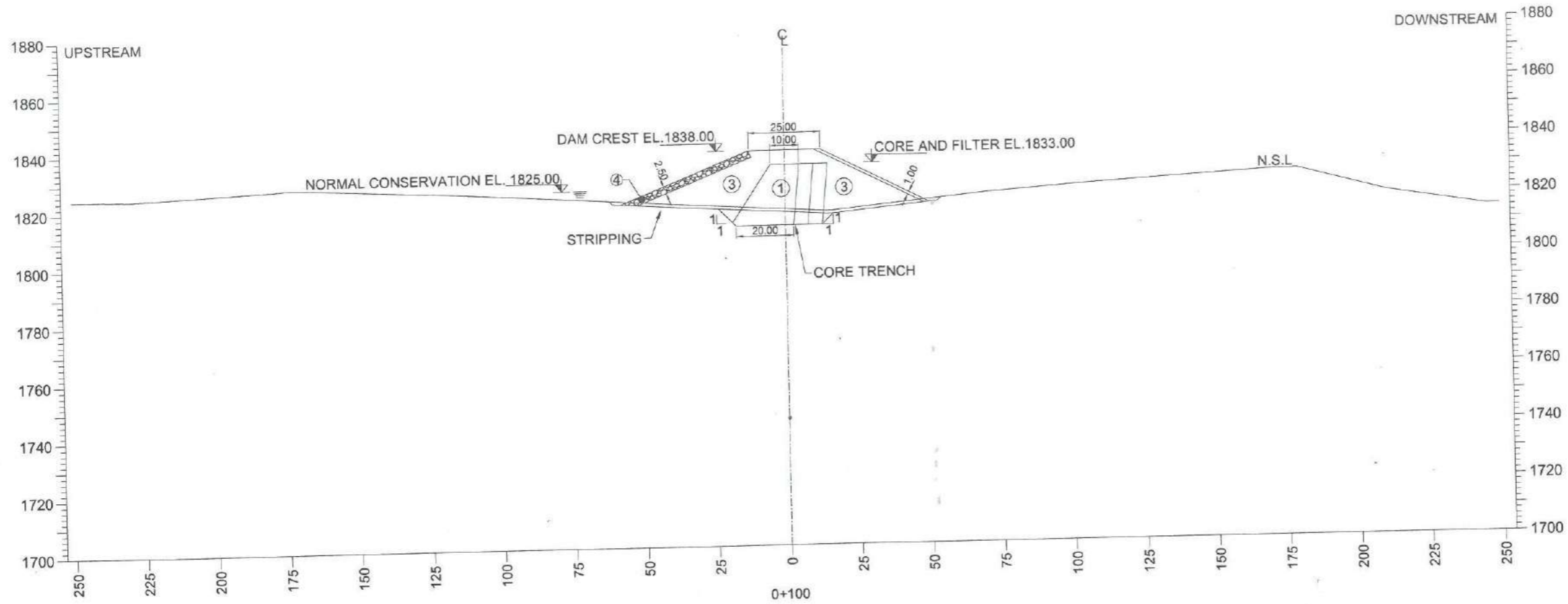

SHEET 2 OF 22



S. NO.	DATE	DESCRIPTIONS	CHECK
		DIRECTORATE GENERAL SMALL DAMS IRRIGATION DEPARTMENT KHYBER PAKHTUNKHAWA	
		SMALL DAM PROJECT	
		SUMARI PAYAN DAM PROJECT DAM X-SECTIONS	
PAKISTAN ENGINEERING SERVICES (PVT.) LTD. 7 - B, COMMERCIAL AREA, PHASE - V, D.H.A, LAHORE.			
DESIGNED BY:	FAROOQ ALI	DATE:	DEC-2023
DESIGNED BY:	AHMED SHAHZAMAR	DRAWING NO.:	
CHECKED BY:	ASHFAQ ALI		D-03
APPROVED BY:	ADNAN MANZOOR		0

NOTES

ALL DIMENSIONS AND LEVELS ARE IN FEET.

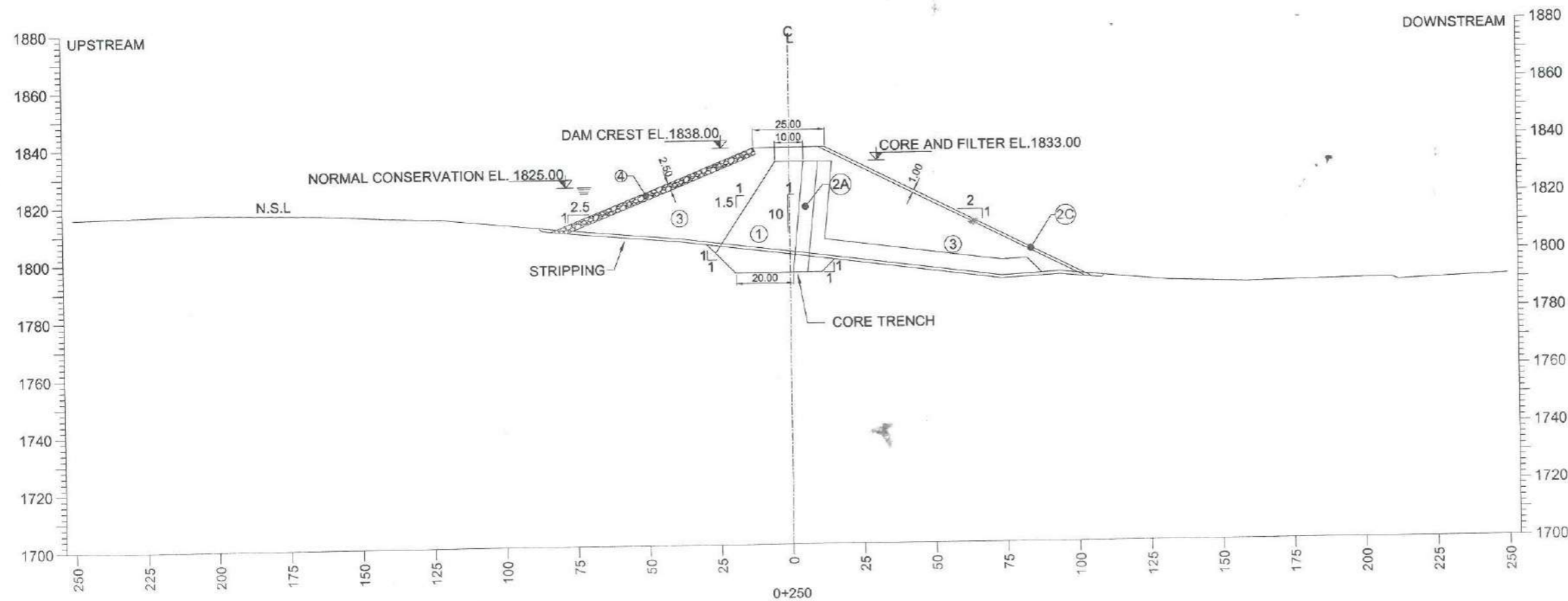
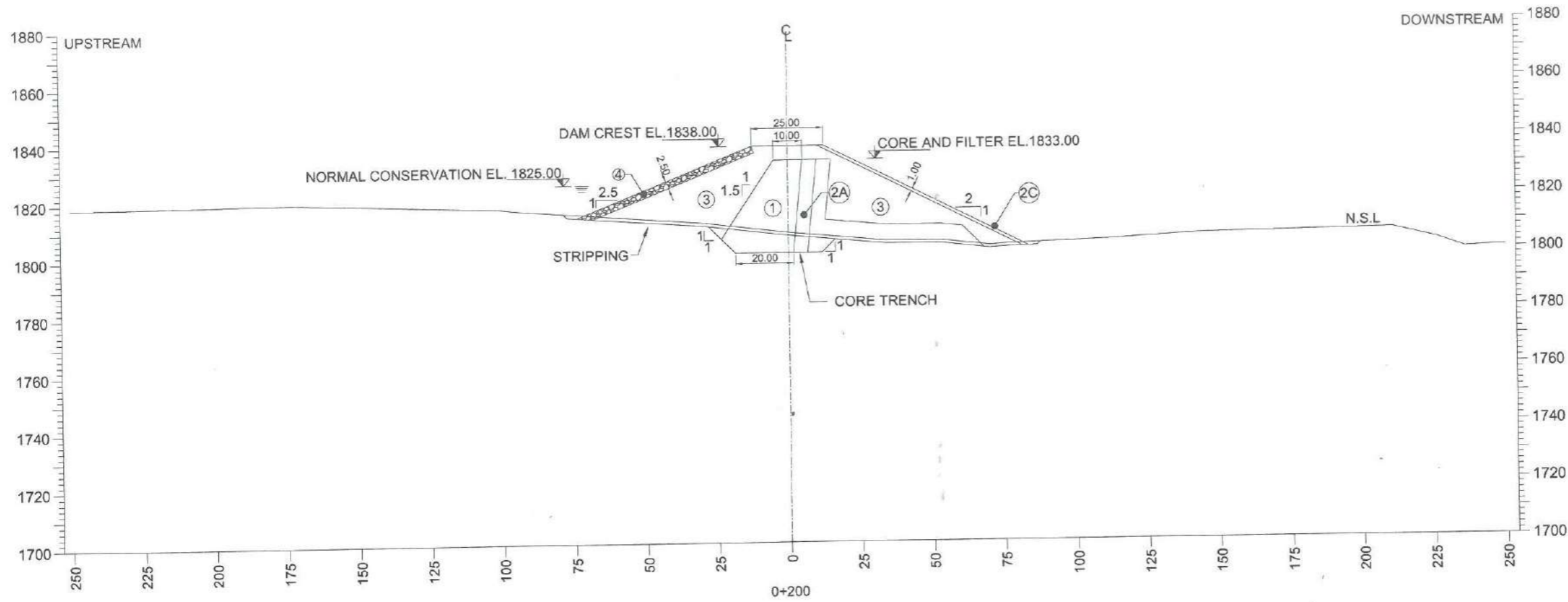

SHEET 3 OF 22



S.NO.	DATE	DESCRIPTIONS	CHECK
DIRECTORATE GENERAL SMALL DAMS IRRIGATION DEPARTMENT KHYBER PAKHTUNKHAWA			
SMALL DAM PROJECT			
SUMARI PAYAN DAM PROJECT DAM X-SECTIONS			
 PAKISTAN ENGINEERING SERVICES (PVT.) LTD. 7 - B, COMMERCIAL AREA, PHASE - V, D.H.A, LAHORE.			
DESIGNED BY:	FAROOQ ALI	DATE:	DEC-2023
DESIGNED BY:	AHMED SHAHZAWAR	DRAWING NO.	
CHECKED BY:	ASHFAQ ALI		D-03
APPROVED BY:	ADNAN MANZOOR		0

NOTES

ALL DIMENSIONS AND LEVELS ARE IN FEET.

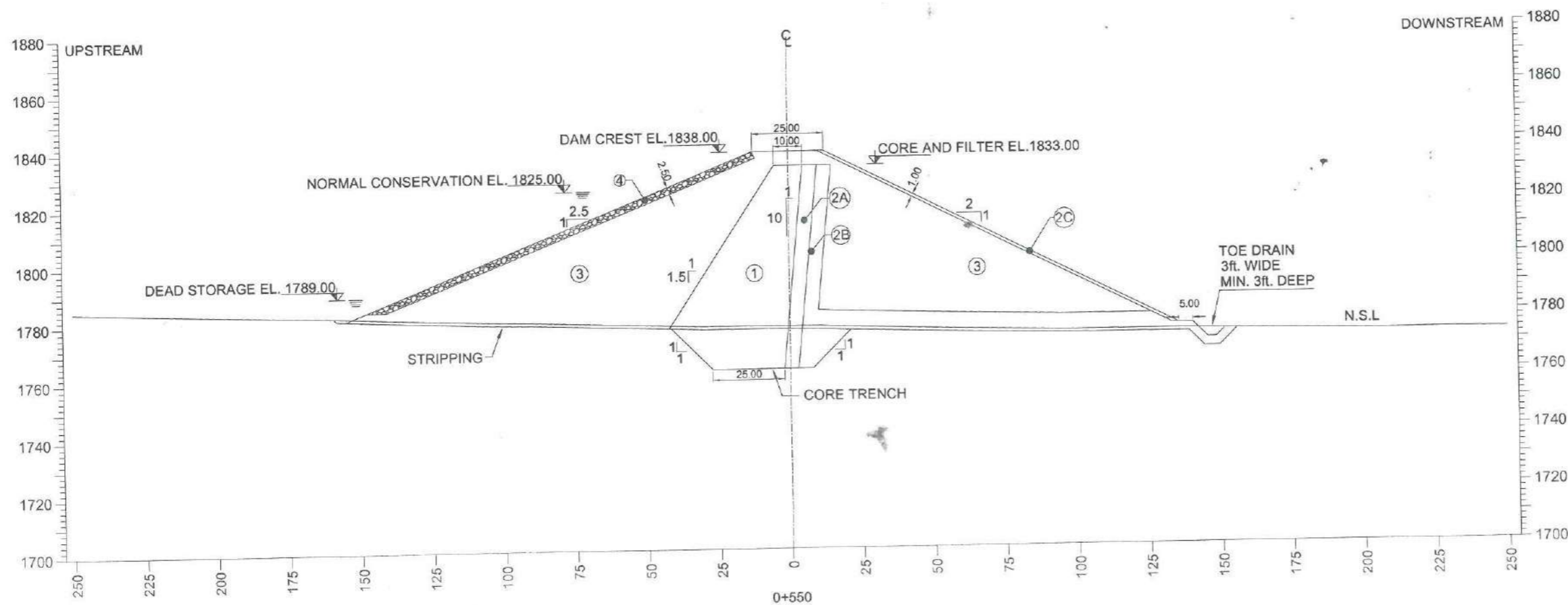
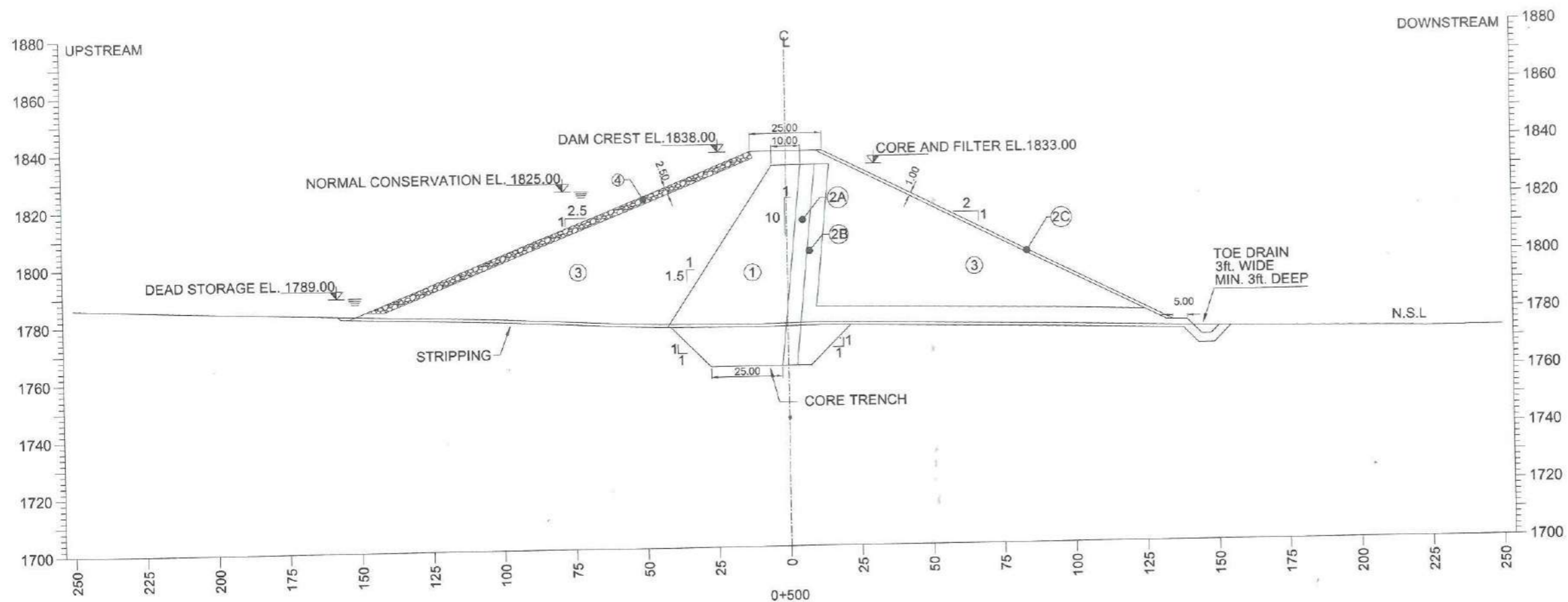

SHEET 6 OF 22



S.NO.	DATE	DESCRIPTIONS	CHECK
DIRECTORATE GENERAL SMALL DAMS IRRIGATION DEPARTMENT KHYBER PAKHTUNKHAWA			
SMALL DAM PROJECT			
SUMARI PAYAN DAM PROJECT DAM X-SECTIONS			
 PAKISTAN ENGINEERING SERVICES (PVT.) LTD. 7 - B, COMMERCIAL AREA, PHASE - V, D.H.A, LAHORE.			
DESIGNED BY:	FAROOQ ALI	DATE:	DEC-2023
DESIGNED:	AHMED SHAHZAWAR	DRAWING NO:	
CHECKED:	ASHFAQ ALI		
APPROVED:	ADNAN MANZOOR	D-03	0

NOTES

ALL DIMENSIONS AND LEVELS ARE IN FEET.

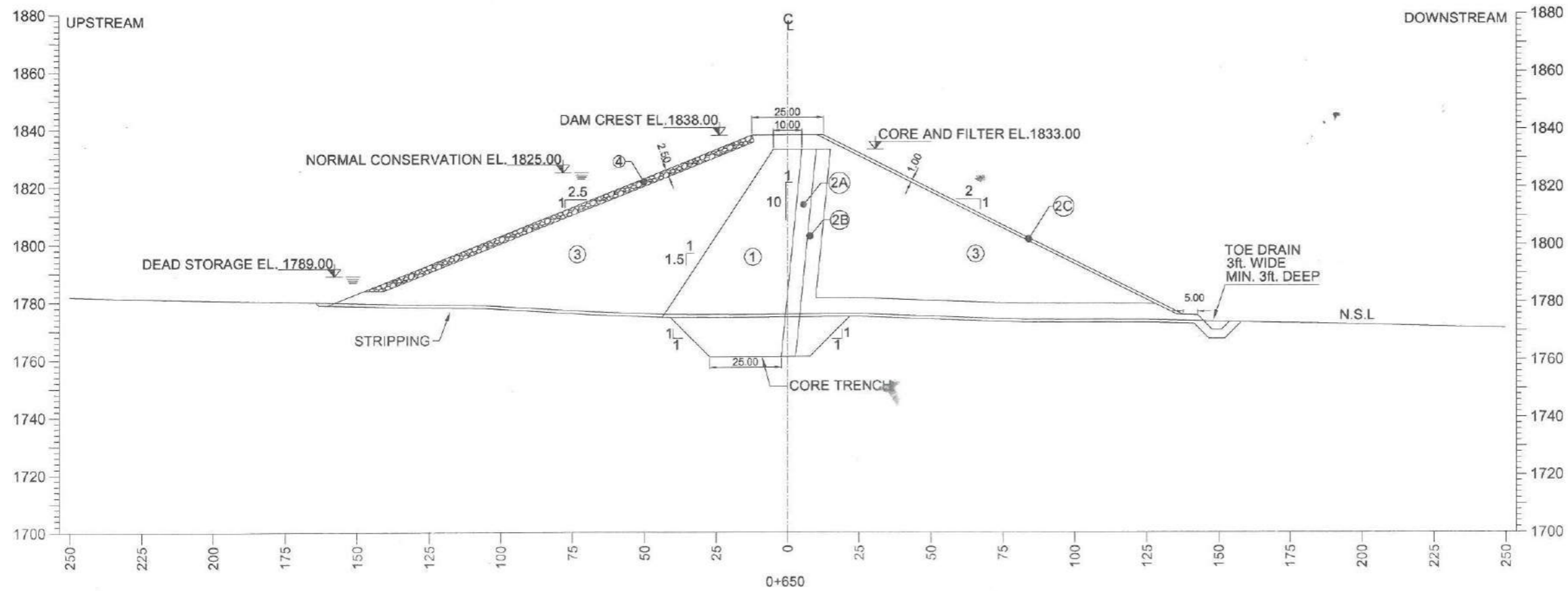
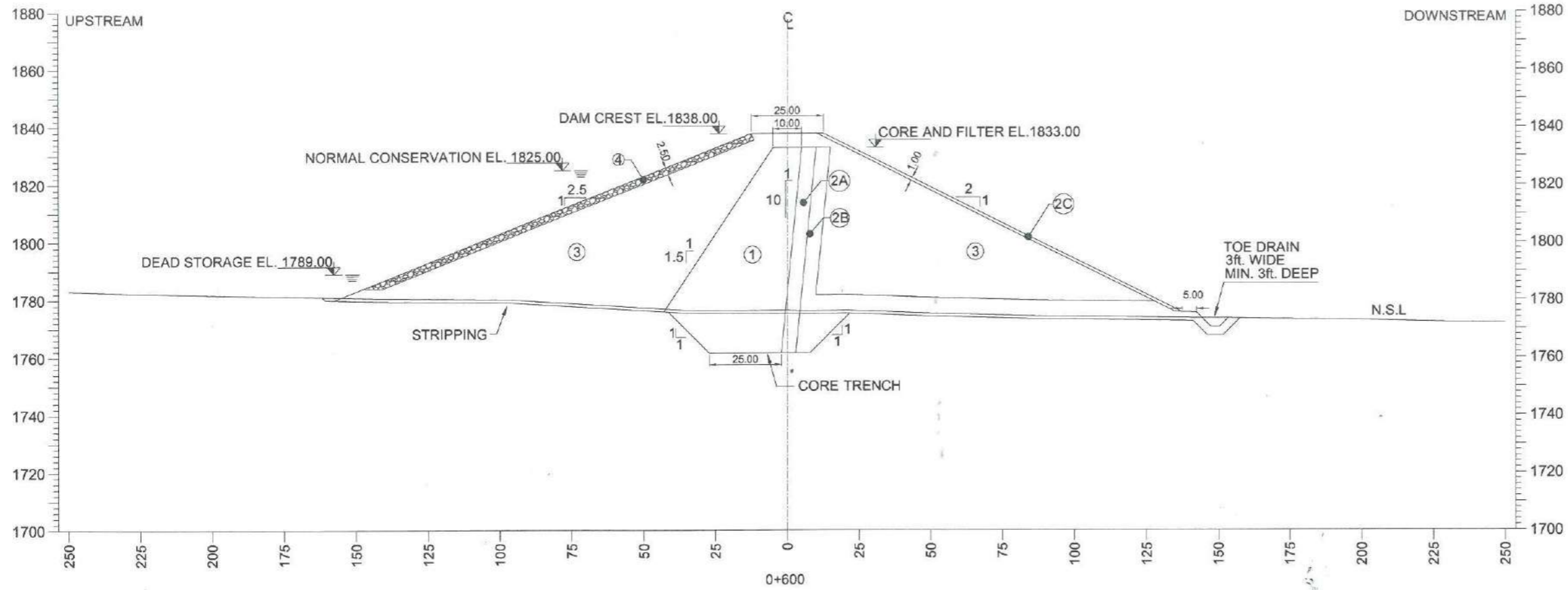

SHEET 7 OF 22



S.NO.	DATE	DESCRIPTIONS	CHECK
DIRECTORATE GENERAL SMALL DAMS IRRIGATION DEPARTMENT KHYBER PAKHTUNKHAWA			
SMALL DAM PROJECT			
SUMARI PAYAN DAM PROJECT DAM X-SECTIONS			
 PAKISTAN ENGINEERING SERVICES (PVT.) LTD. 7 - B, COMMERCIAL AREA, PHASE - V, D.H.A, LAHORE.			
DESIGNED BY:	FAROOQ ALI	DATE:	DEC-2023
DESIGNED BY:	AHMED SHAHZAWAR	DRAWING NO.:	
CHECKED:	ASHFAQ ALI		
APPROVED:	ADNAN MANZOOR		
		D-03	0

NOTES

ALL DIMENSIONS AND LEVELS ARE IN FEET.

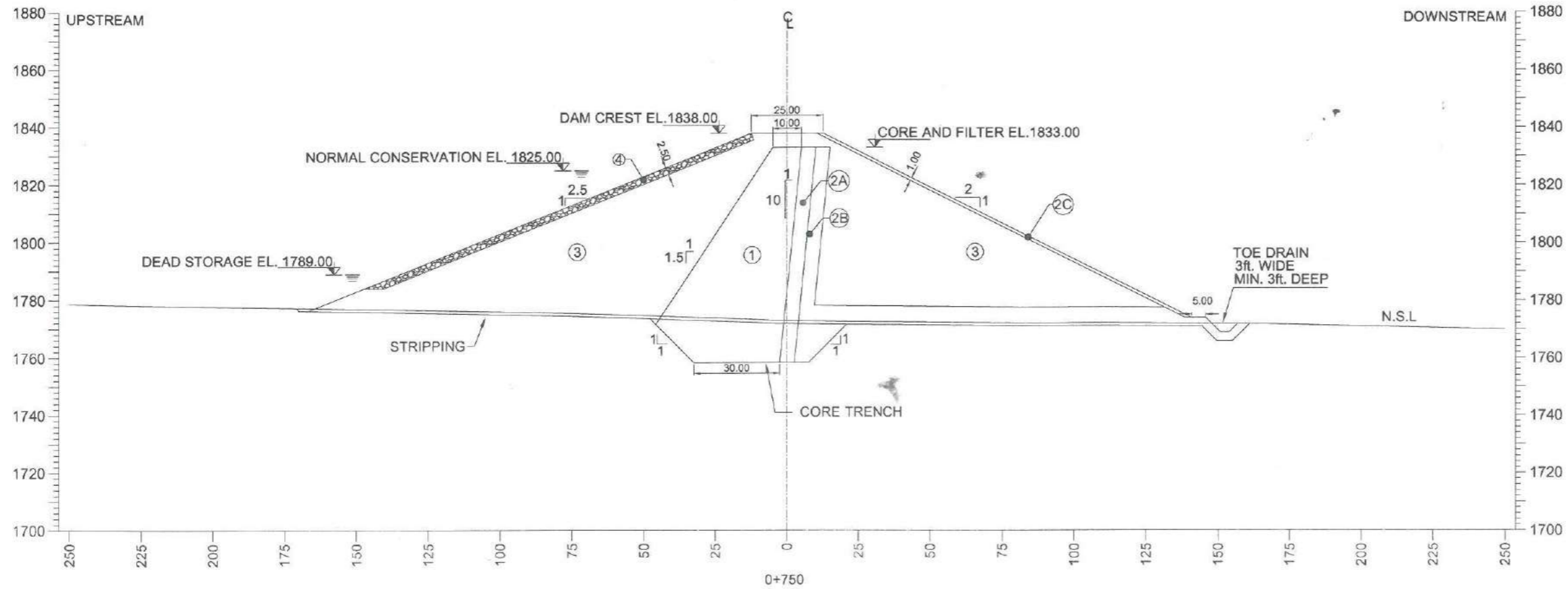
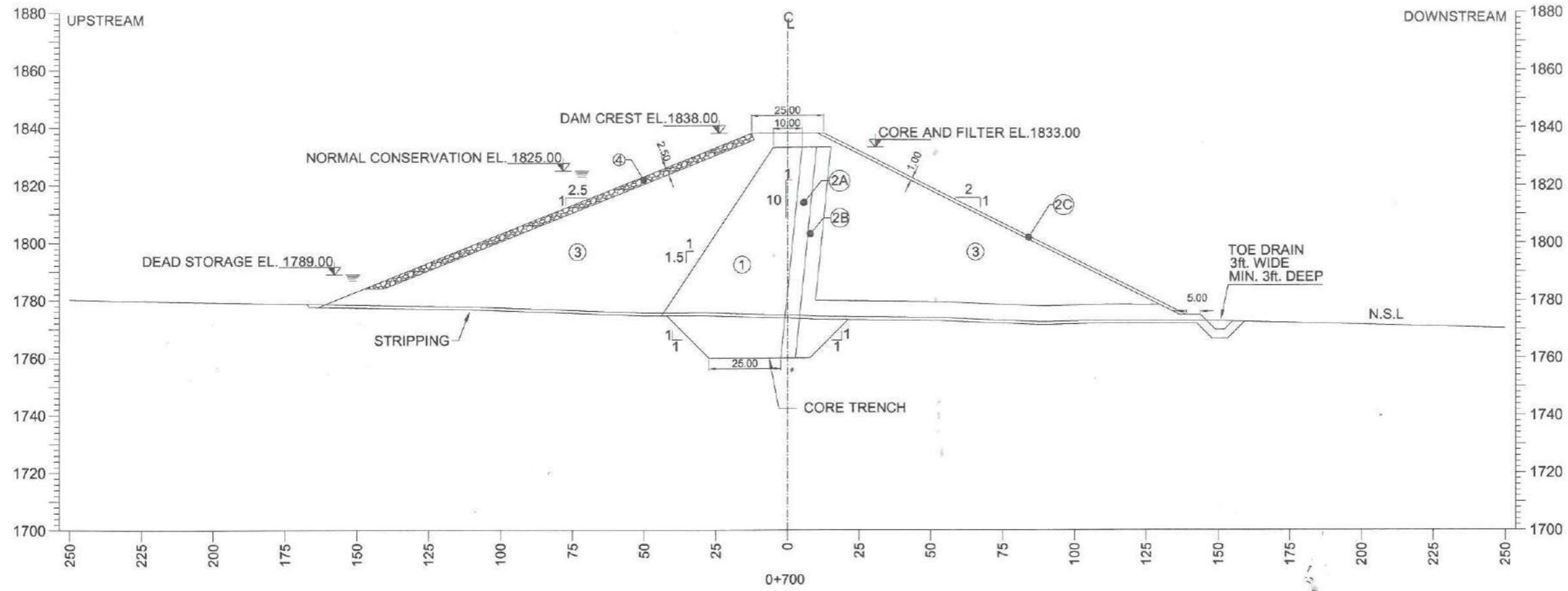

SHEET 8 OF 22



S. NO.	DATE	DESCRIPTIONS	CHECK
DIRECTORATE GENERAL SMALL DAMS IRRIGATION DEPARTMENT KHYBER PAKHTUNKHAWA			
SMALL DAM PROJECT			
SUMARI PAYAN DAM PROJECT DAM X-SECTIONS			
 PAKISTAN ENGINEERING SERVICES (PVT.) LTD. 7 - B, COMMERCIAL AREA, PHASE - V, D.H.A, LAHORE.			
DRAFTER: DESIGNED: CHECKED: APPROVED:	FAROOQ ALI AHMED SHAHZADAN ASHFAQ ALI ADNAN MANZOOR	DATE: DEC-2023 DRAWING NO. D-03	REV. No. 0

NOTES

ALL DIMENSIONS AND LEVELS ARE IN FEET.

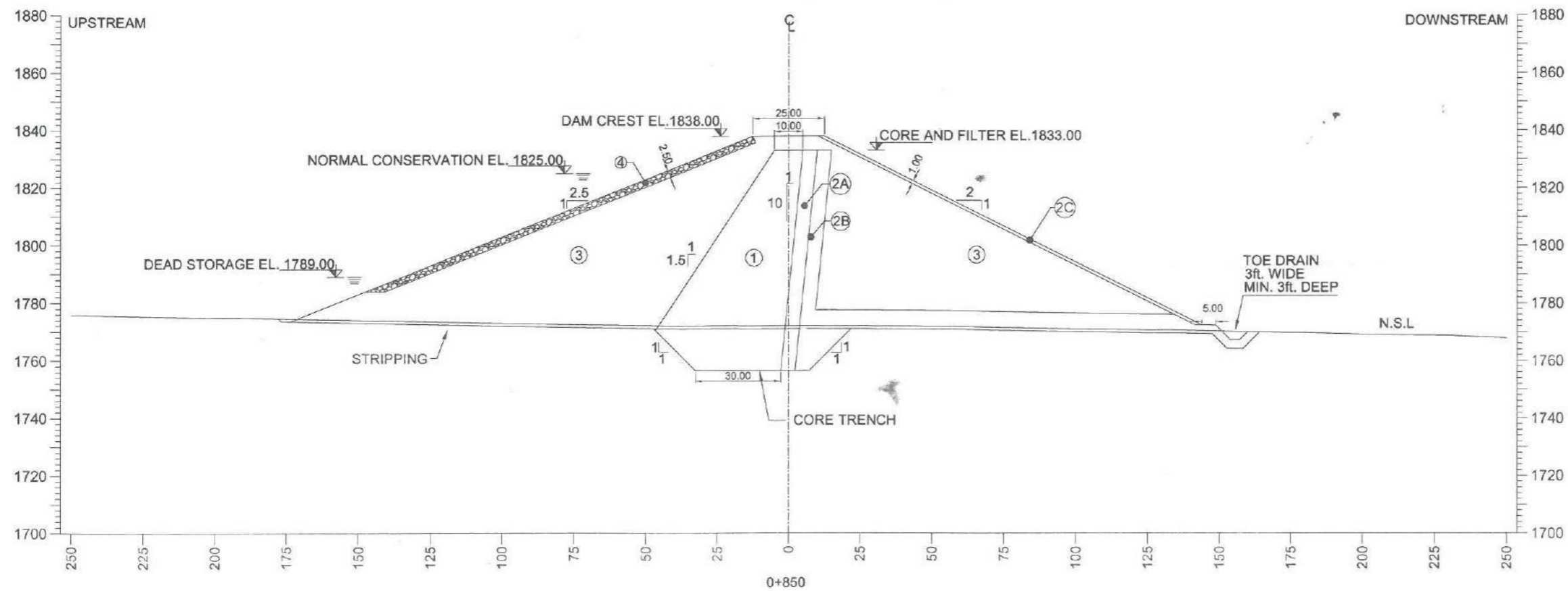
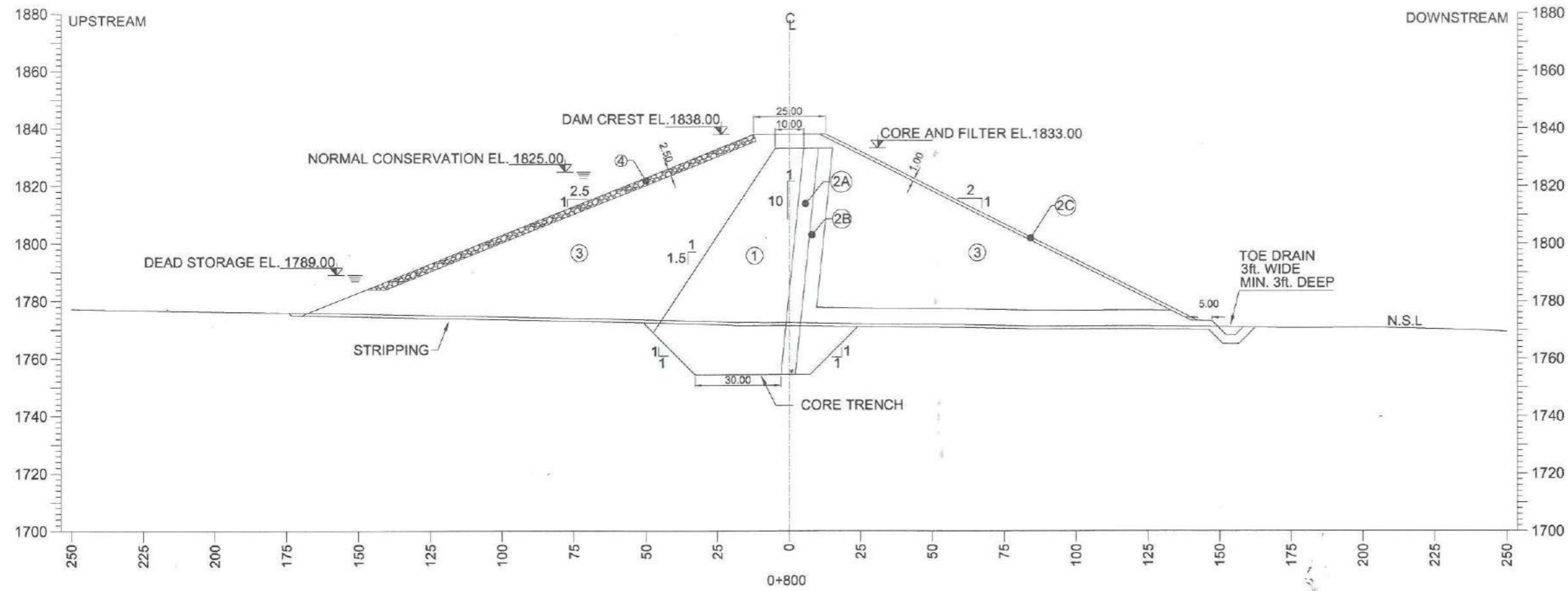

SHEET 9 OF 22



S.NO.	DATE	DESCRIPTIONS	CHECK
DIRECTORATE GENERAL SMALL DAMS IRRIGATION DEPARTMENT KHYBER PAKHTUNKHAWA			
SMALL DAM PROJECT			
SUMARI PAYAN DAM PROJECT DAM X-SECTIONS			
 PAKISTAN ENGINEERING SERVICES (PVT.) LTD. 7 - B, COMMERCIAL AREA, PHASE - V, D.H.A, LAHORE.			
DESIGNED BY:	FAROOQ ALI	DATE:	DEC-2023
DESIGNED BY:	AHMED SHAHZAWAR	DRAWING NO.	
CHECKED BY:	ASHFAQ ALI		
APPROVED BY:	ADNAN MANZOOR	D-03	0

NOTES

ALL DIMENSIONS AND LEVELS ARE IN FEET.

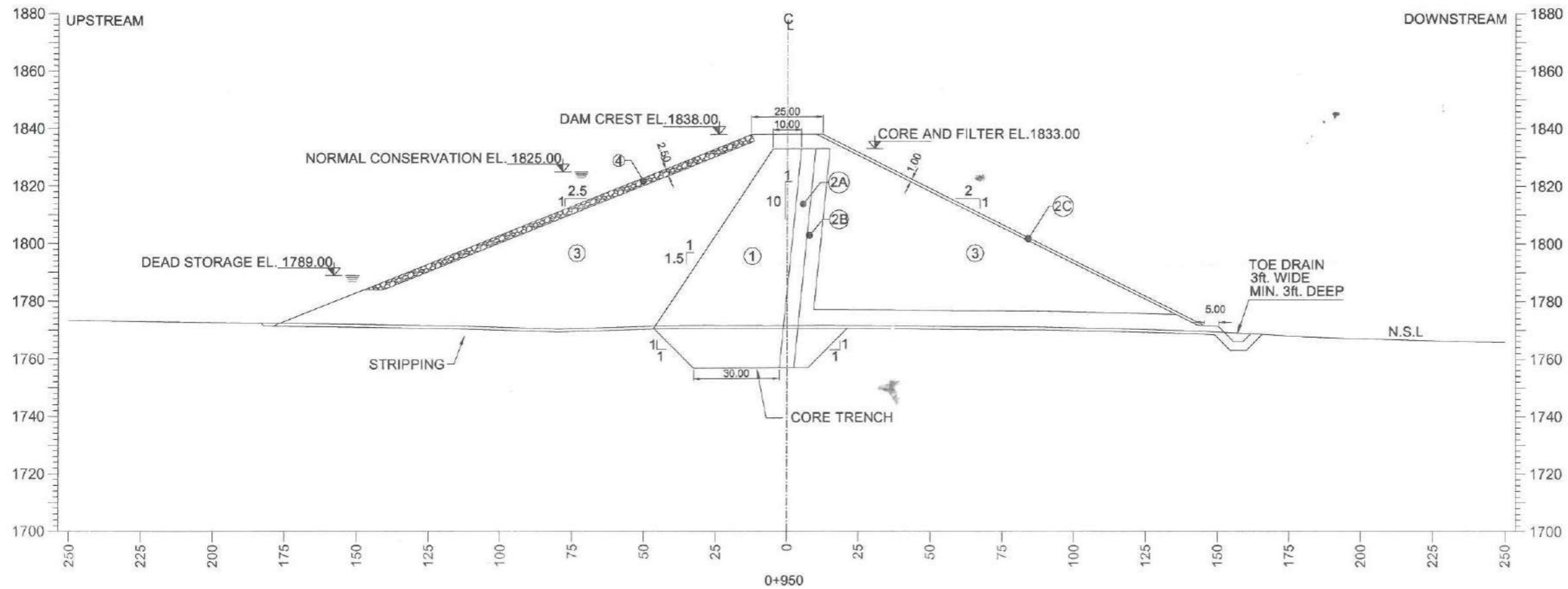
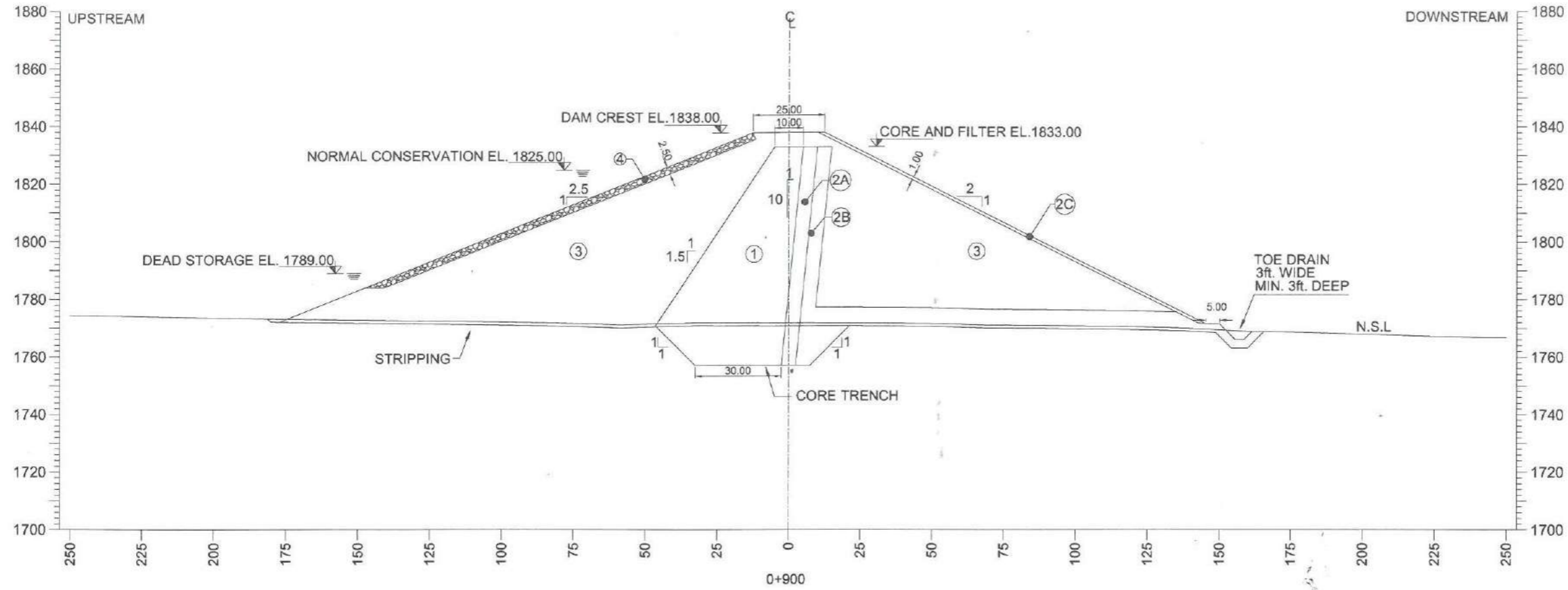

SHEET 10 OF 22



S.NO	DATE	DESCRIPTIONS	CHECK
DIRECTORATE GENERAL SMALL DAMS IRRIGATION DEPARTMENT KHYBER PAKHTUNKHAWA			
SMALL DAM PROJECT			
SUMARI PAYAN DAM PROJECT DAM X-SECTIONS			
 PAKISTAN ENGINEERING SERVICES (PVT.) LTD. 7 - B, COMMERCIAL AREA, PHASE - V, D.H.A. LAHORE.			
DESIGNED BY:	FAROOQ ALI	DATE:	DEC-2023
DESIGNED BY:	AHMED SHAHZANAR	DRAWING NO.	
CHECKED BY:	ASHFAQ ALI		D-03
APPROVED BY:	ADNAN MANZOOR		0

NOTES

ALL DIMENSIONS AND LEVELS ARE IN FEET.

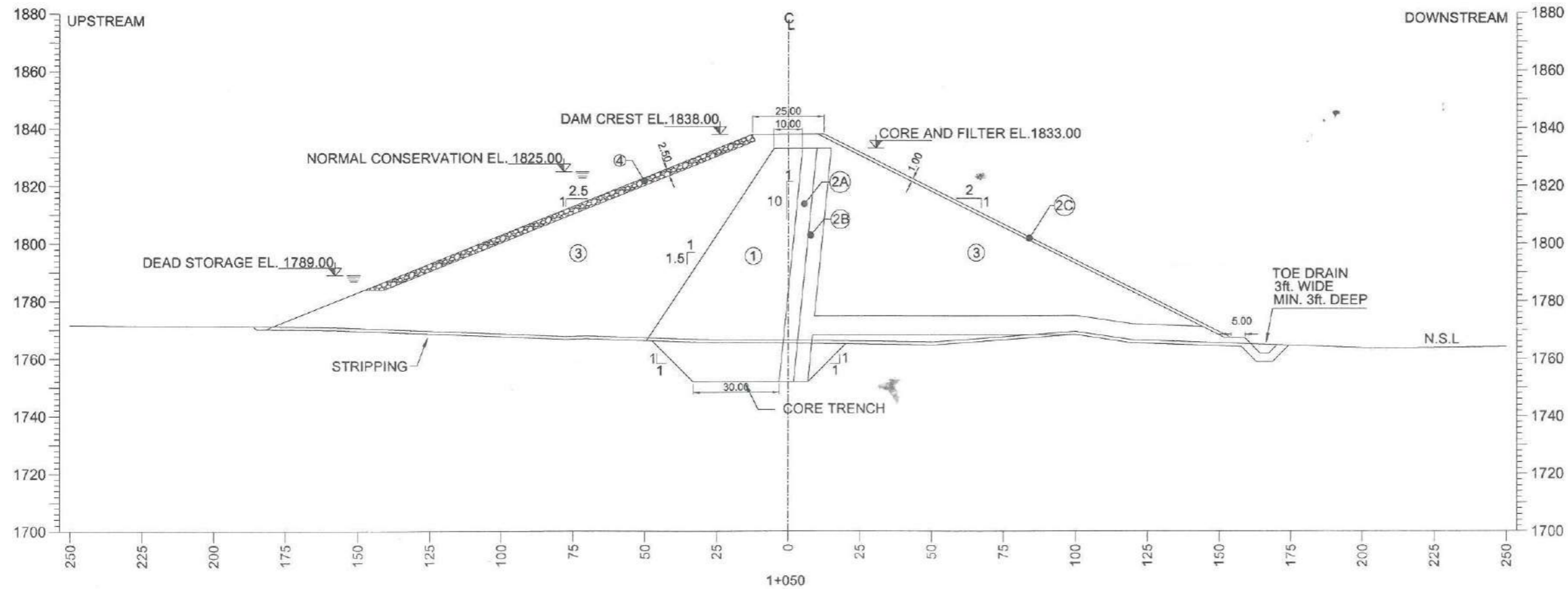
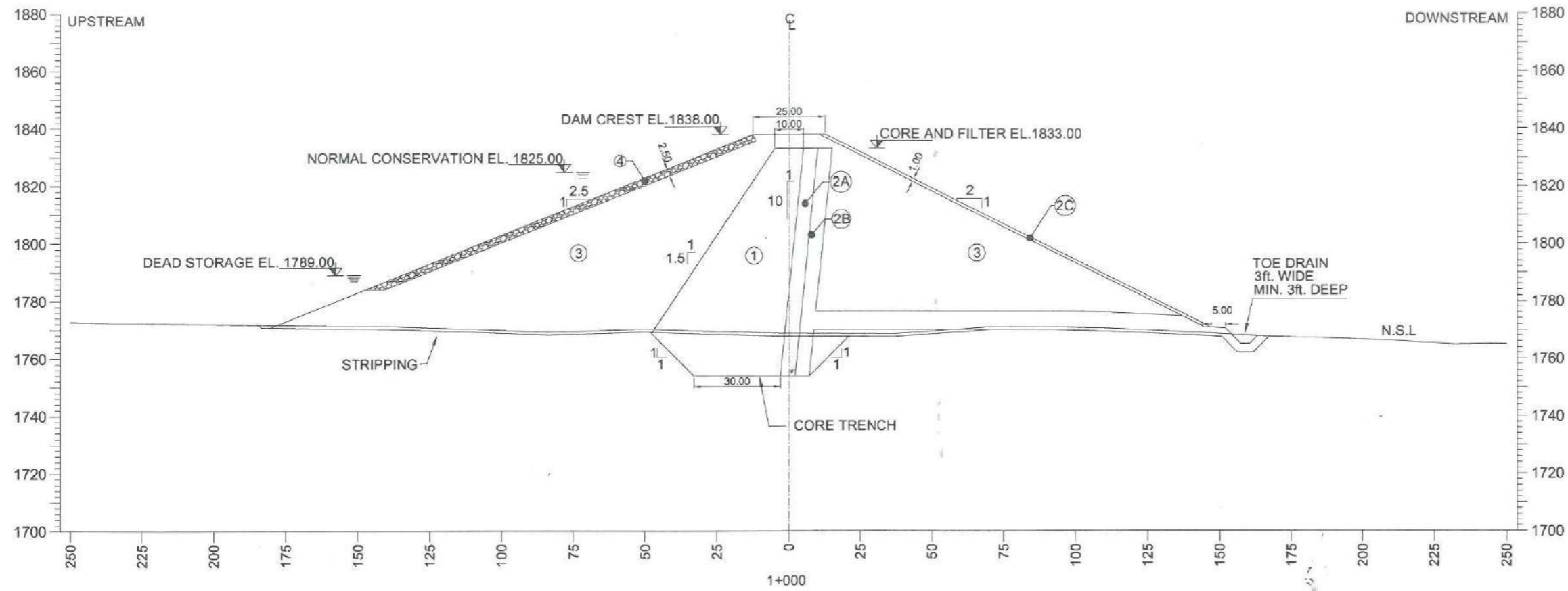

SHEET 11 OF 22



S.NO.	DATE	DESCRIPTIONS	CHECK
DIRECTORATE GENERAL SMALL DAMS IRRIGATION DEPARTMENT KHYBER PAKHTUNKHAWA			
SMALL DAM PROJECT			
SUMARI PAYAN DAM PROJECT DAM X-SECTIONS			
 PAKISTAN ENGINEERING SERVICES (PVT.) LTD. 7 - B, COMMERCIAL AREA, PHASE - V, D.H.A. LAHORE.			
DESIGNED BY:	FAROOQ ALI	DATE:	DEC-2023
DESIGNED BY:	AHMED SHAHZAWAR	DRAWING NO.:	
CHECKED BY:	ASHFAQ ALI		D-03
APPROVED BY:	ADNAN MANZOOR		0

NOTES

ALL DIMENSIONS AND LEVELS ARE IN FEET.

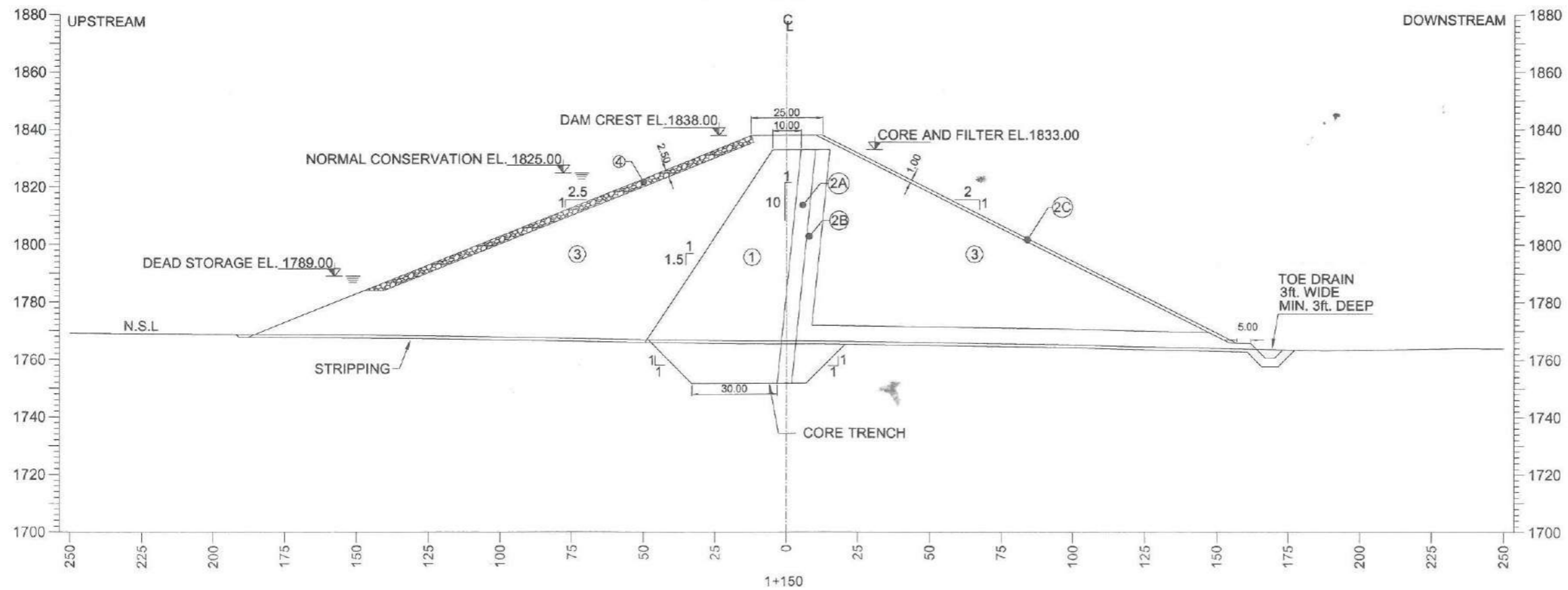
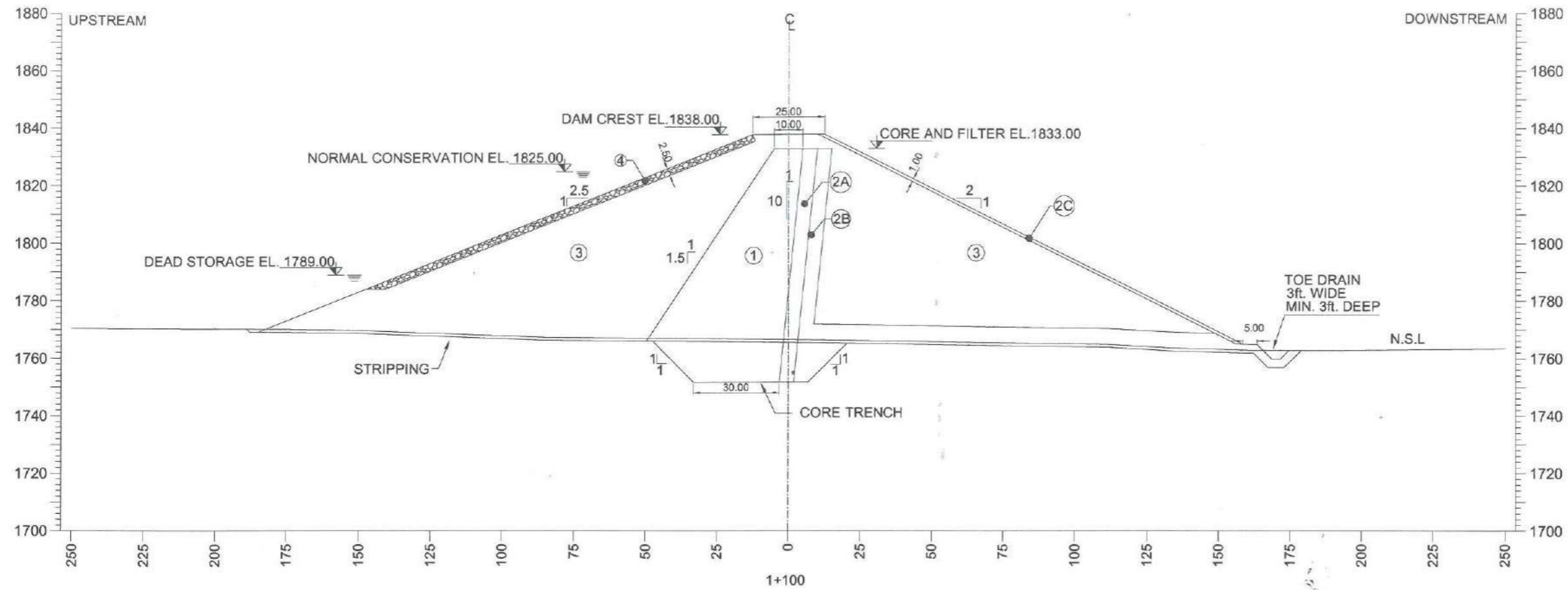

SHEET 12 OF 22



S.NO.	DATE	DESCRIPTIONS	CHECK
DIRECTORATE GENERAL SMALL DAMS IRRIGATION DEPARTMENT KHYBER PAKHTUNKHAWA			
SMALL DAM PROJECT			
SUMARI PAYAN DAM PROJECT DAM X-SECTIONS			
 PAKISTAN ENGINEERING SERVICES (PVT.) LTD. 7 - B, COMMERCIAL AREA, PHASE - V, D.H.A, LAHORE.			
DESIGNED BY:	FAROOQ ALI	DATE:	DEC-2023
DESIGNED BY:	AHMED SHAHZAD	REV. No	
CHECKED BY:	ASHFAQ ALI	DRAWING NO.	
APPROVED BY:	ADNAN MANZOOR	D-03	0

NOTES

ALL DIMENSIONS AND LEVELS ARE IN FEET.

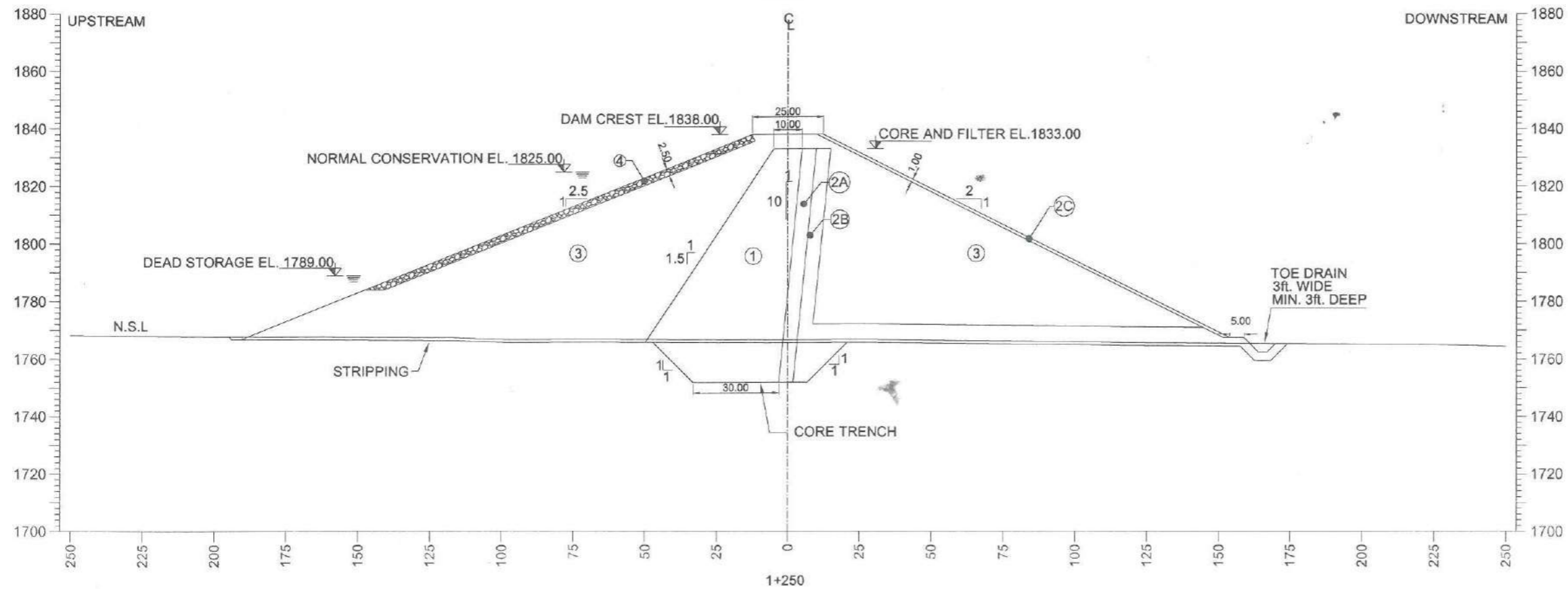
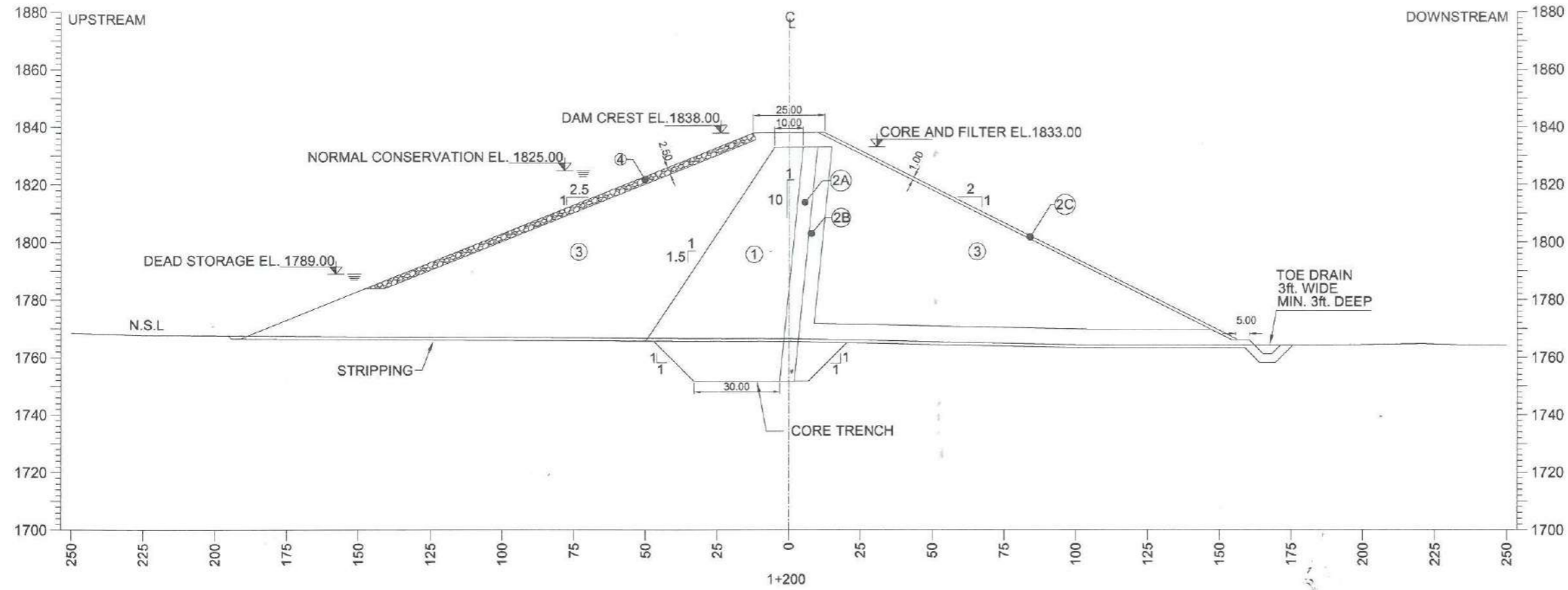

SHEET 13 OF 22



S.NO.	DATE	DESCRIPTIONS	CHECK
DIRECTORATE GENERAL SMALL DAMS IRRIGATION DEPARTMENT KHYBER PAKHTUNKHAWA			
SMALL DAM PROJECT			
SUMARI PAYAN DAM PROJECT DAM X-SECTIONS			
 PAKISTAN ENGINEERING SERVICES (PVT.) LTD. 7 - B, COMMERCIAL AREA, PHASE - V, D.H.A, LAHORE.			
DESIGNED BY:	FAROOQ ALI	DATE:	DEC-2023
DESIGNED BY:	AHMED SHAHZAWAR	DRAWING NO.	
CHECKED BY:	ASHFAQ ALI		
APPROVED BY:	ADNAN MANZOOR	D-03	0

NOTES

ALL DIMENSIONS AND LEVELS ARE IN FEET.

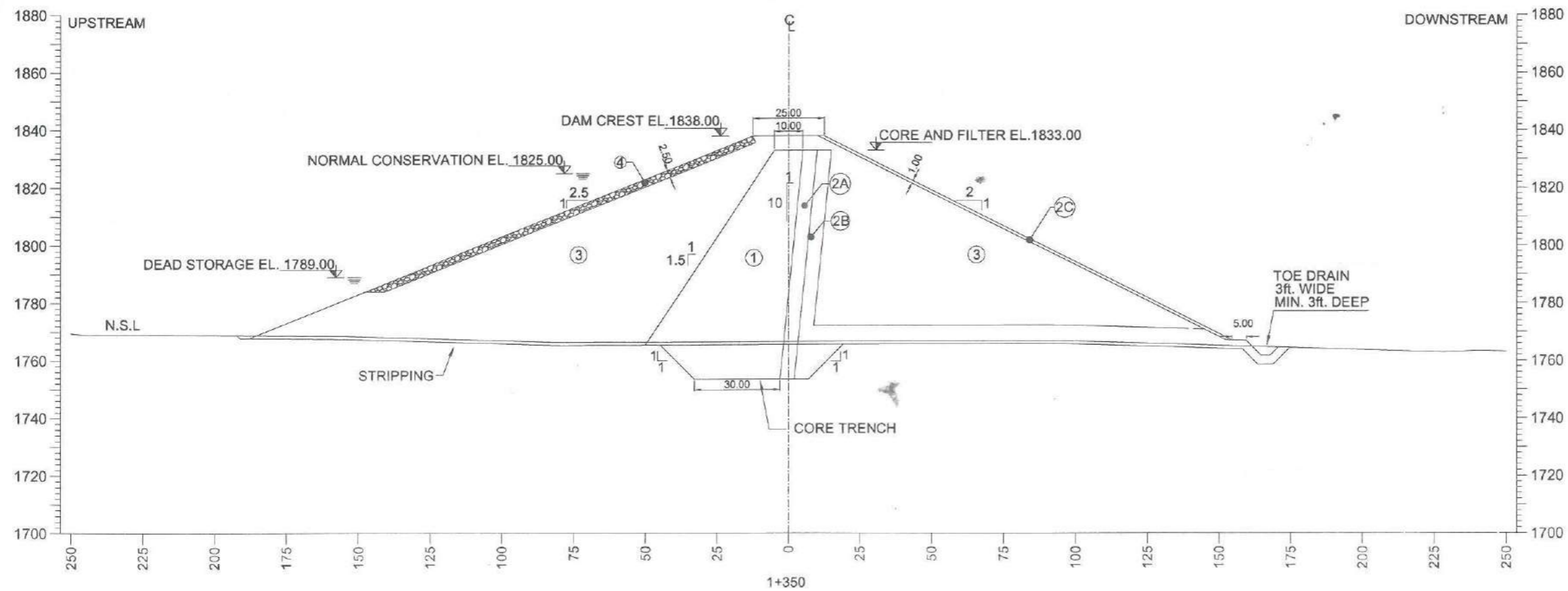
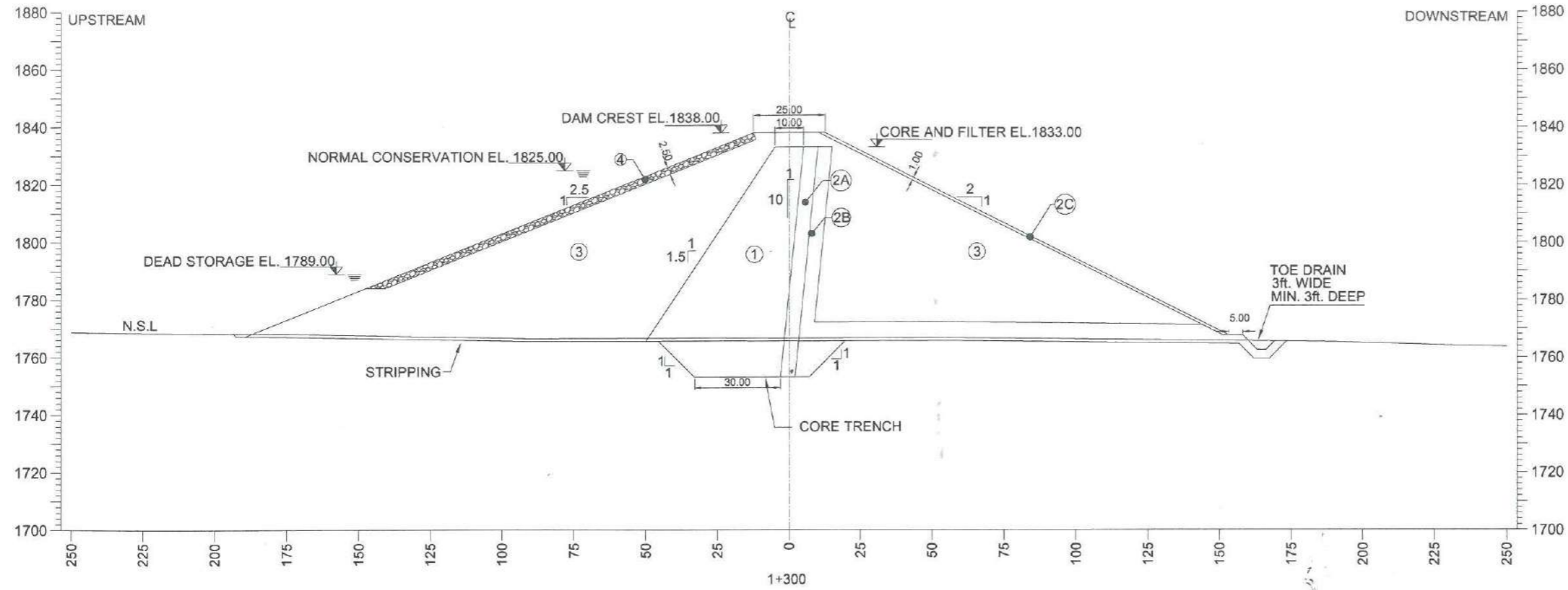

SHEET 14 OF 22



S.NO.	DATE	DESCRIPTIONS	CHECK
DIRECTORATE GENERAL SMALL DAMS IRRIGATION DEPARTMENT KHYBER PAKHTUNKHAWA			
SMALL DAM PROJECT			
SUMARI PAYAN DAM PROJECT DAM X-SECTIONS			
PAKISTAN ENGINEERING SERVICES (PVT.) LTD. 7 - B, COMMERCIAL AREA, PHASE - V, D.H.A, LAHORE.			
DESIGNED BY:	FAROOQ ALI	DATE:	DEC-2023
DESIGNED BY:	AHMED SHAHZAWAR	DRAWING NO.	
CHECKED BY:	ASHFAQ ALI		
APPROVED BY:	ADNAN MANZOOR		
		D-03	0

NOTES

ALL DIMENSIONS AND LEVELS ARE IN FEET.

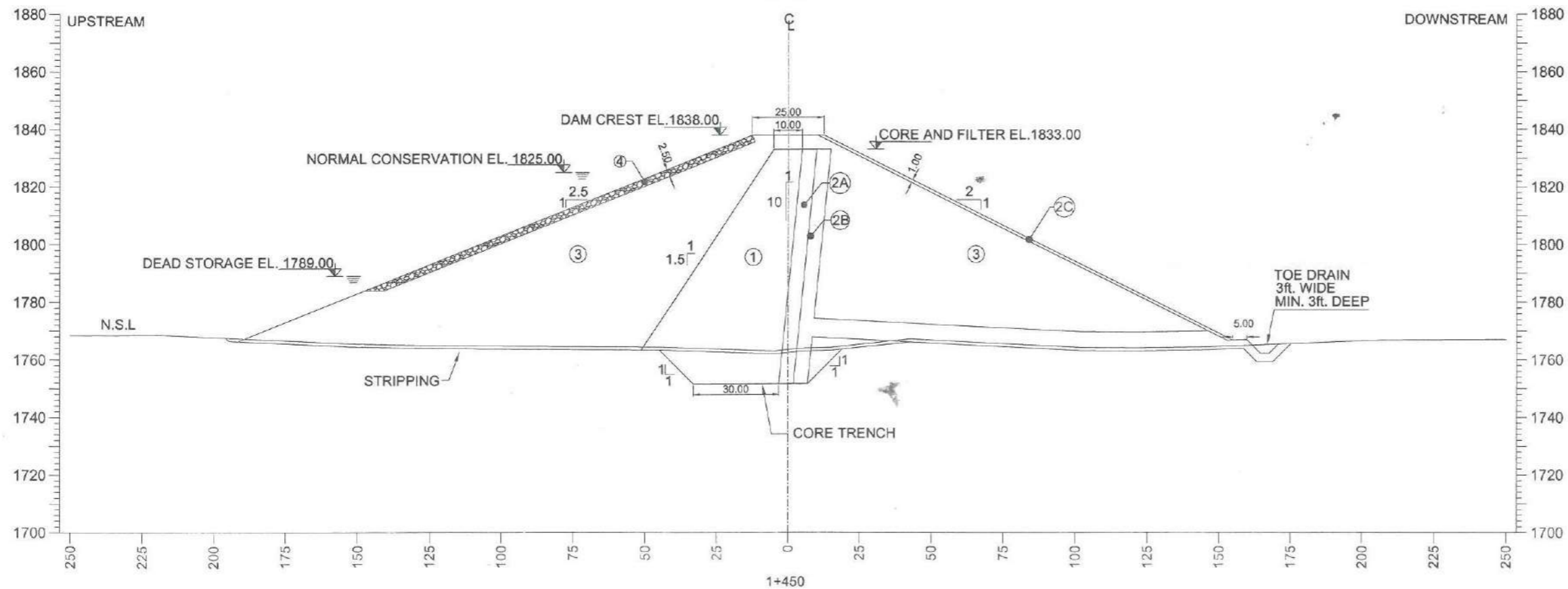
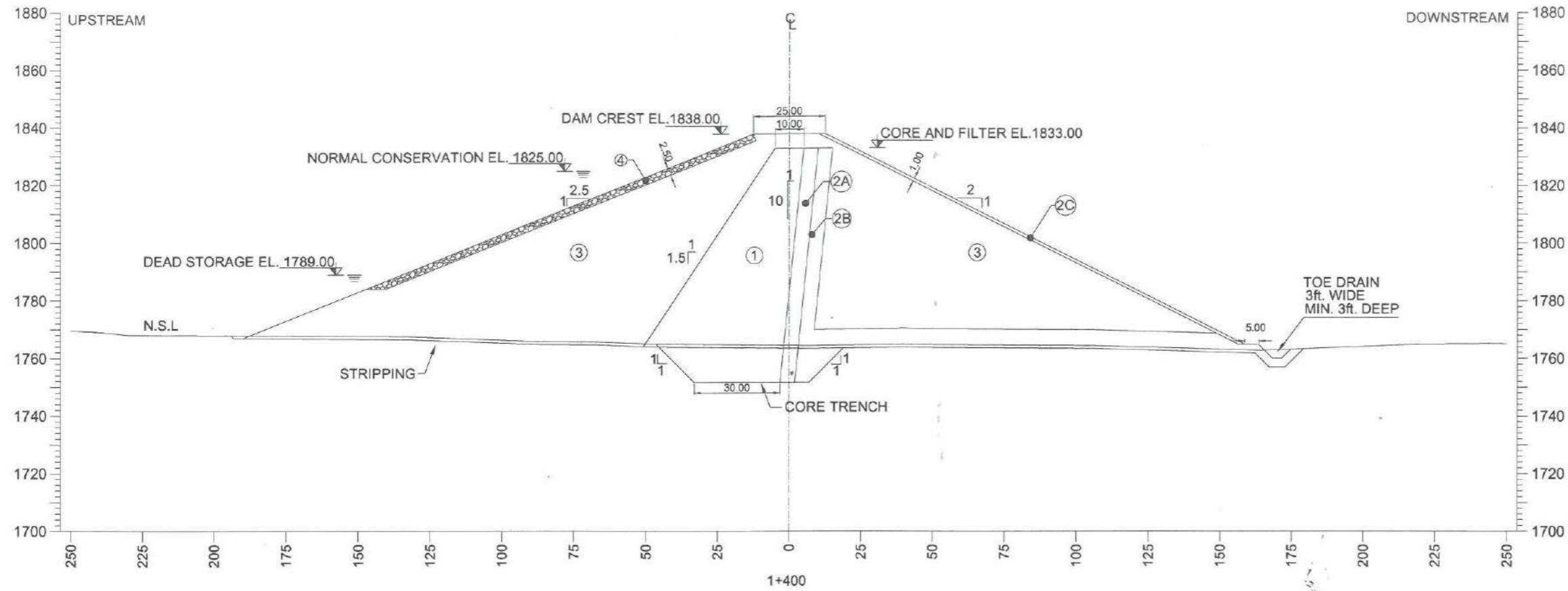

SHEET 15 OF 22



S.N.O	DATE	DESCRIPTIONS	CHECK
DIRECTORATE GENERAL SMALL DAMS IRRIGATION DEPARTMENT KHYBER PAKHTUNKHAWA			
SMALL DAM PROJECT			
SUMARI PAYAN DAM PROJECT DAM X-SECTIONS			
 PAKISTAN ENGINEERING SERVICES (PVT.) LTD. 7 - B, COMMERCIAL AREA, PHASE - V, D.H.A, LAHORE.			
DESIGNED BY:	FAROOQ ALI	DATE:	DEC-2023
DESIGNED BY:	AHMED SHAHZAWAR	DRAWING NO.:	
CHECKED BY:	ASHEEQ ALI		
APPROVED BY:	ADNAN MANZOOR		
			REV. No.
			D-03
			0

NOTES

ALL DIMENSIONS AND LEVELS ARE IN FEET.

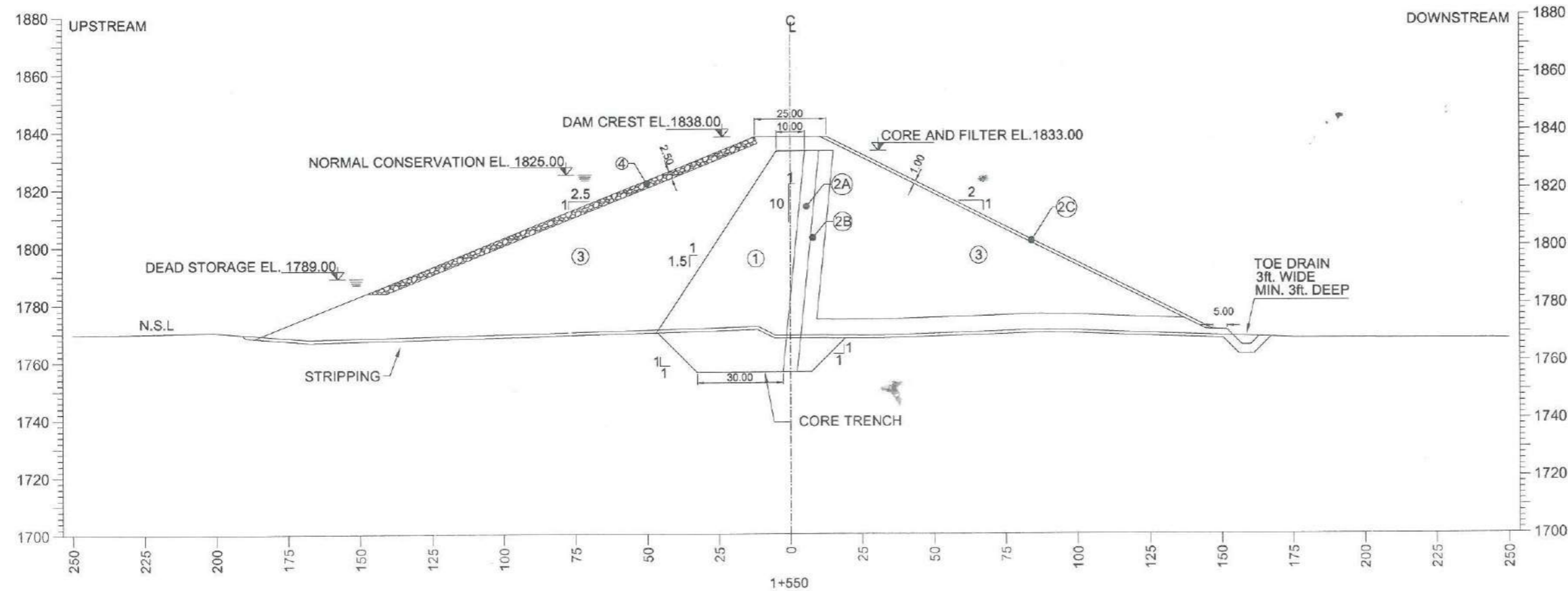
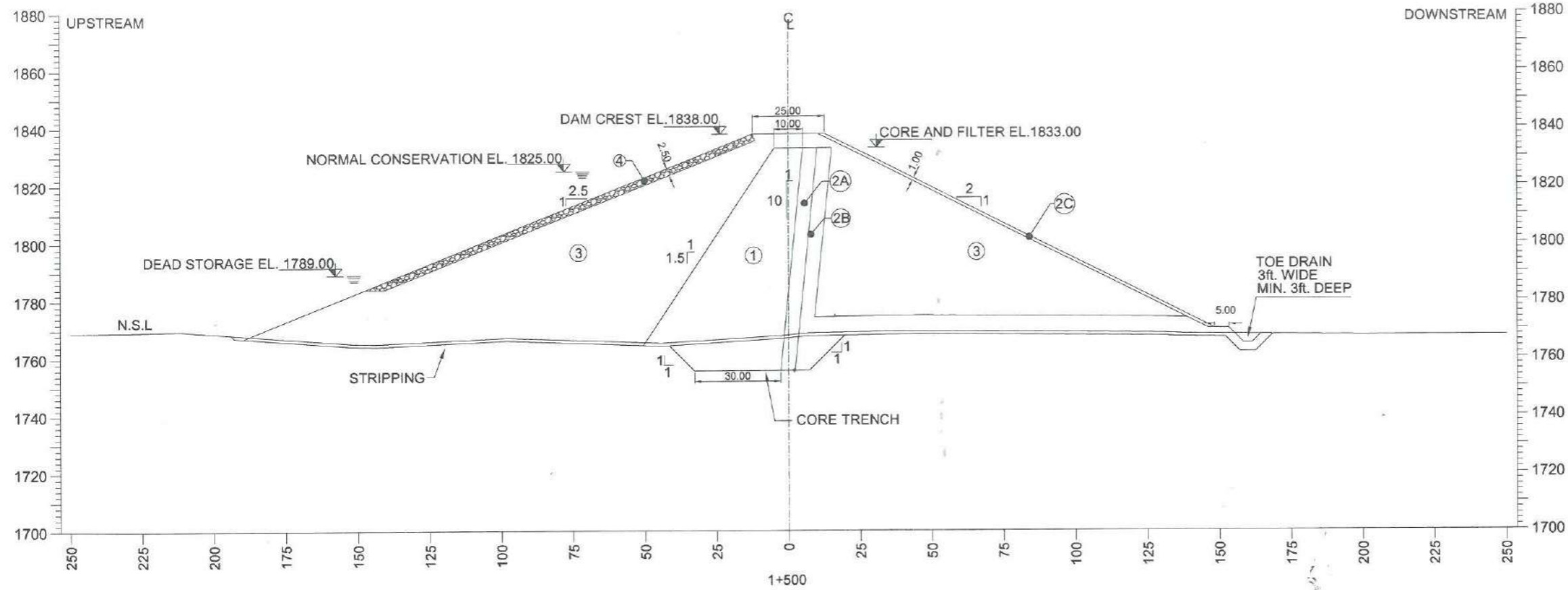

SHEET 16 OF 22



S.NO.	DATE	DESCRIPTIONS	CHECK
DIRECTORATE GENERAL SMALL DAMS IRRIGATION DEPARTMENT KHYBER PAKHTUNKHAWA			
SMALL DAM PROJECT			
SUMARI PAYAN DAM PROJECT DAM X-SECTIONS			
 PAKISTAN ENGINEERING SERVICES (PVT.) LTD. 7 - B, COMMERCIAL AREA, PHASE - V, D.H.A, LAHORE.			
DESIGNED BY:	FAROOQ ALI	DATE:	DEC-2023
DESIGNED:	AHMED SHAHZAWAR	DRAWING NO.:	
CHECKED:	ASHFAQ ALI		
APPROVED:	ADNAN MANZOOR		
		D-03	0

NOTES

ALL DIMENSIONS AND LEVELS ARE IN FEET.

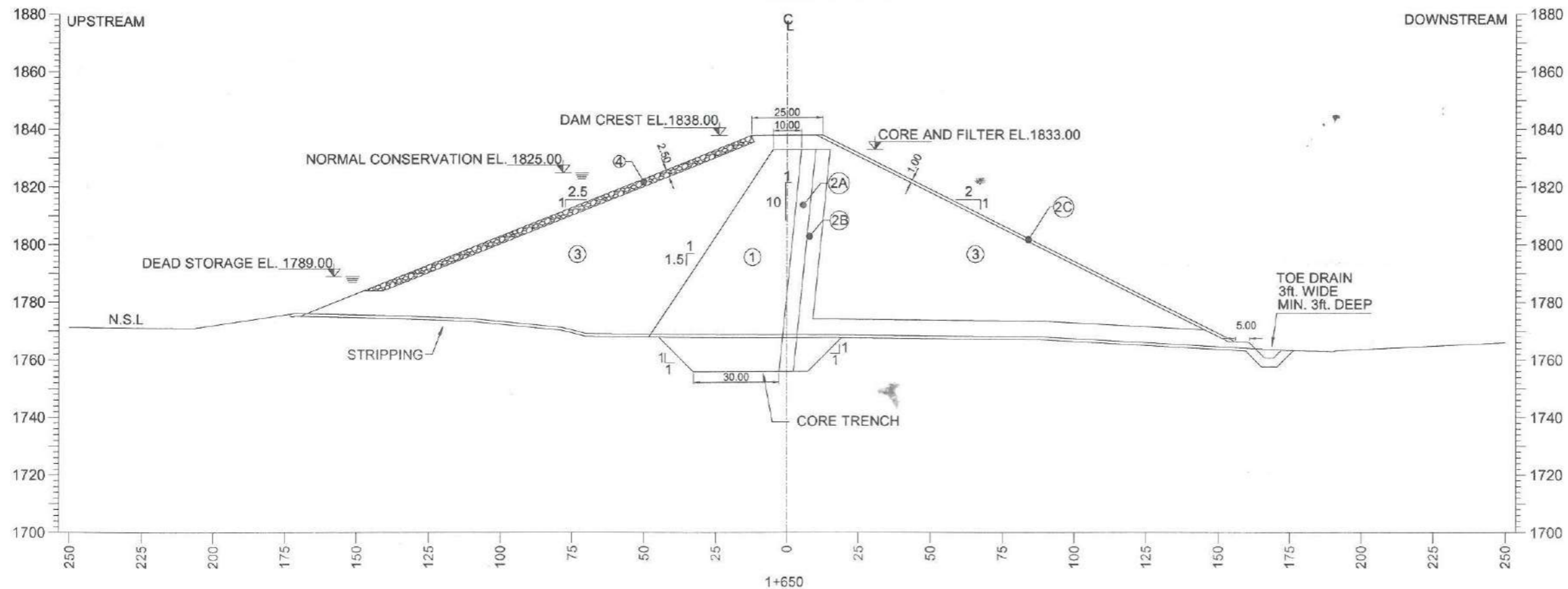
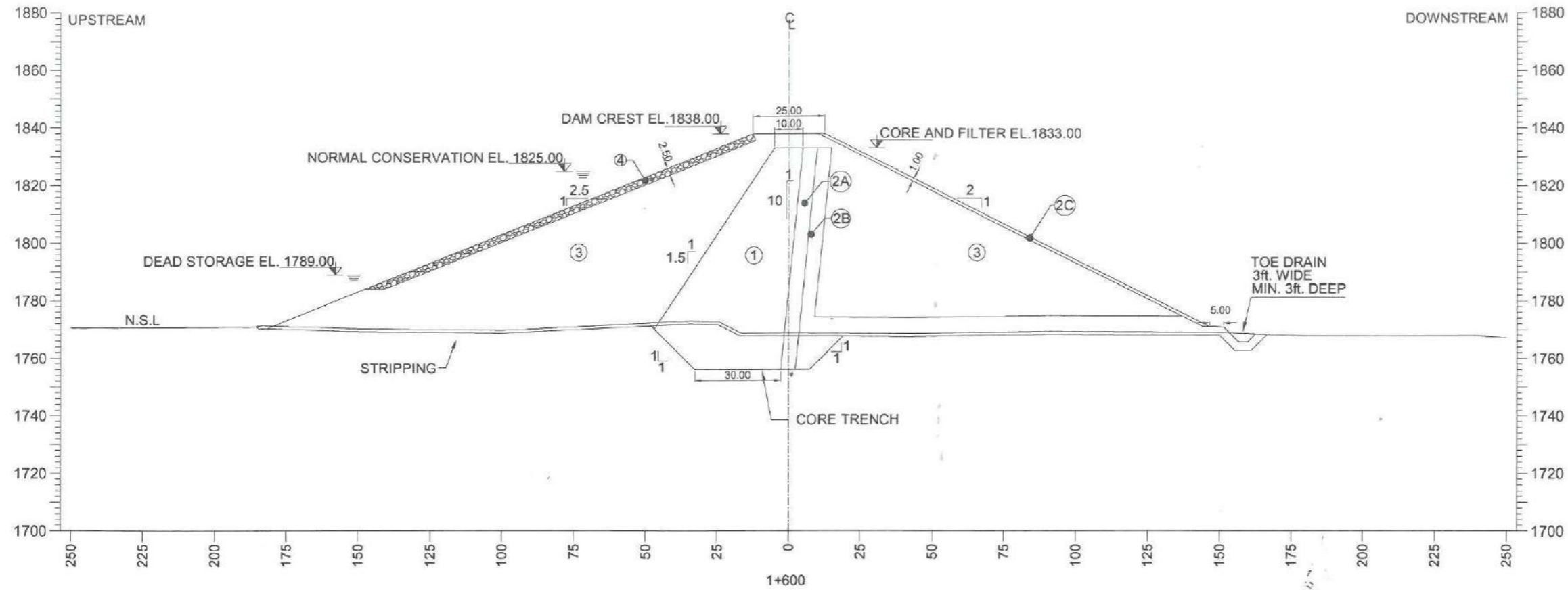

SHEET 17 OF 22



S.NO.	DATE	DESCRIPTIONS	CHECK
DIRECTORATE GENERAL SMALL DAMS IRRIGATION DEPARTMENT KHYBER PAKHTUNKHAWA			
SMALL DAM PROJECT			
SUMARI PAYAN DAM PROJECT DAM X-SECTIONS			
 PAKISTAN ENGINEERING SERVICES (PVT.) LTD. 7 - B, COMMERCIAL AREA, PHASE - V, D.H.A, LAHORE.			
DESIGNED BY:	FAROOQ ALI	DATE:	DEC-2023
DESIGNED BY:	AHMED SHAHZAWAR	DRAWING NO.	
CHECKED:	ASHFAQ ALI		
APPROVED:	ADNAN MANZOOR		
		D-03	0

NOTES

ALL DIMENSIONS AND LEVELS ARE IN FEET.

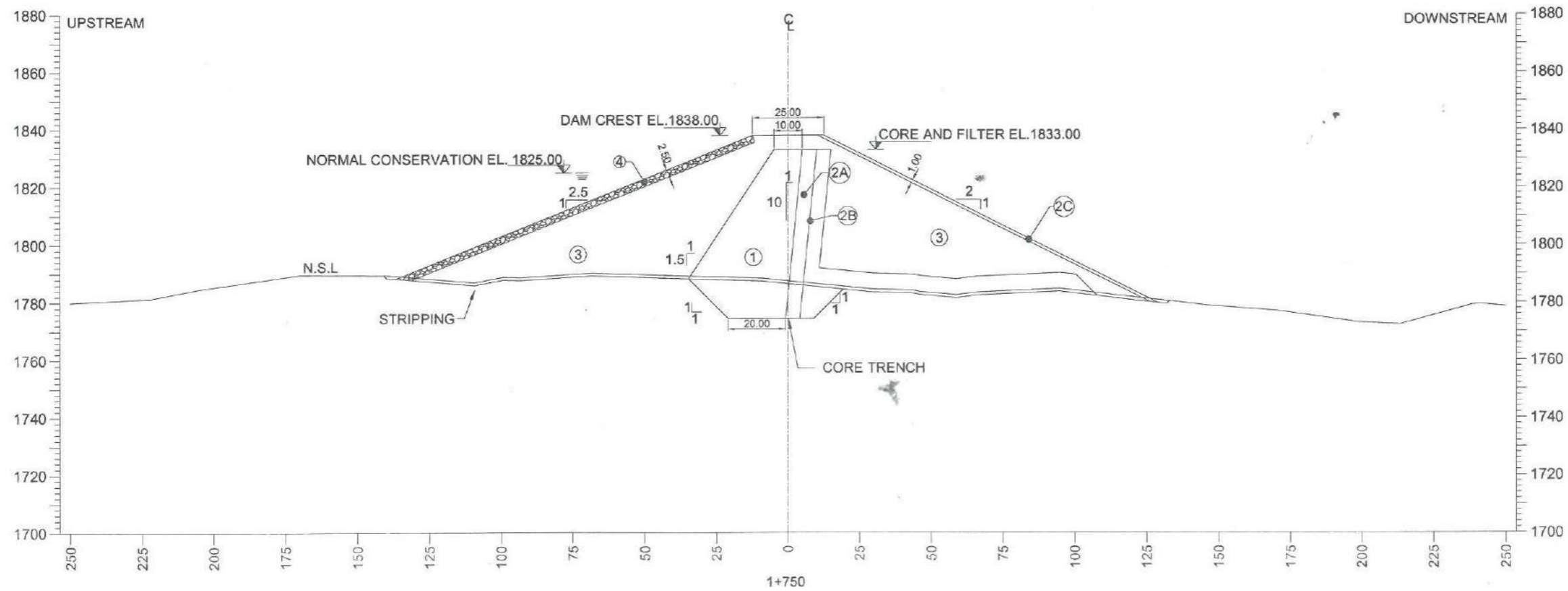
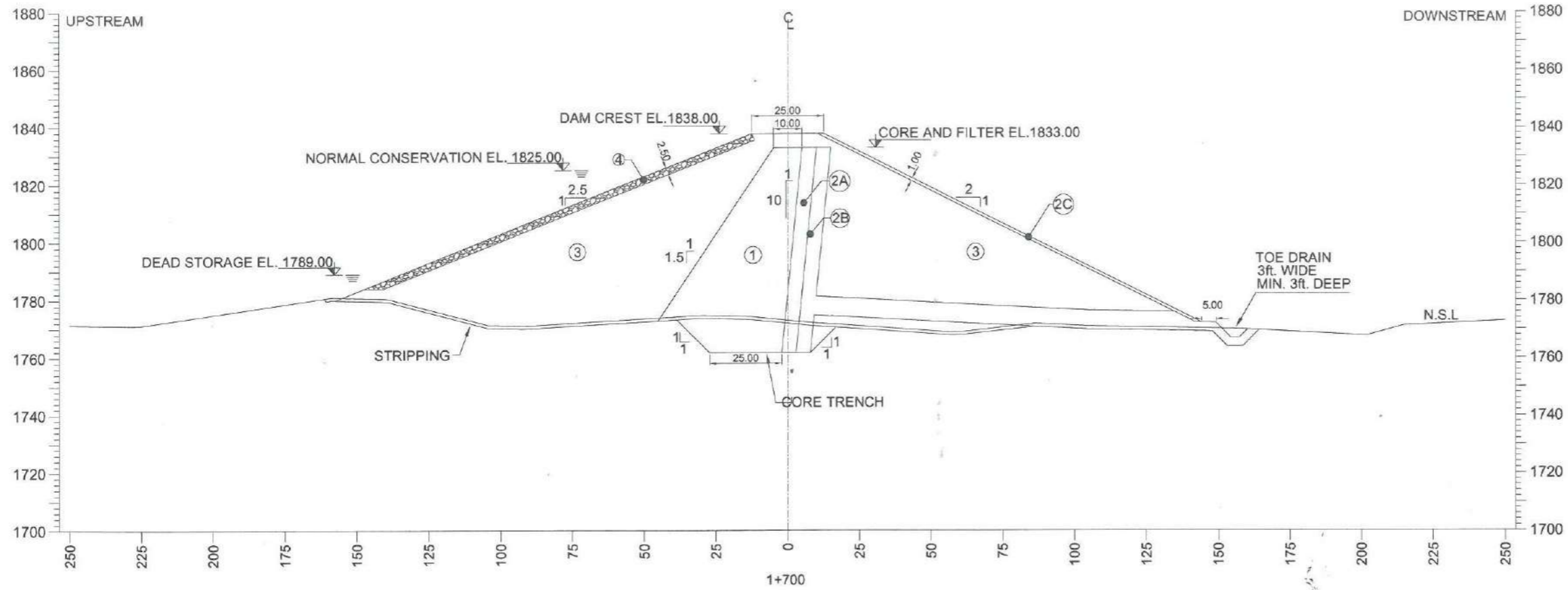

SHEET 18 OF 22



S.NO.	DATE	DESCRIPTIONS	CHECK
DIRECTORATE GENERAL SMALL DAMS IRRIGATION DEPARTMENT KHYBER PAKHTUNKHAWA			
SMALL DAM PROJECT			
SUMARI PAYAN DAM PROJECT DAM X-SECTIONS			
PAKISTAN ENGINEERING SERVICES (PVT.) LTD. 7 - B, COMMERCIAL AREA, PHASE - V, D.H.A, LAHORE.			
DESIGNED BY:	FAROOQ ALI	DATE:	DEC-2023
DESIGNED:	AHMED SHAHZAWAR	DRAWING NO.	
CHECKED:	ASHFAQ ALI		
APPROVED:	ADNAN MANZOOR	D-03	0

NOTES

ALL DIMENSIONS AND LEVELS ARE IN FEET.

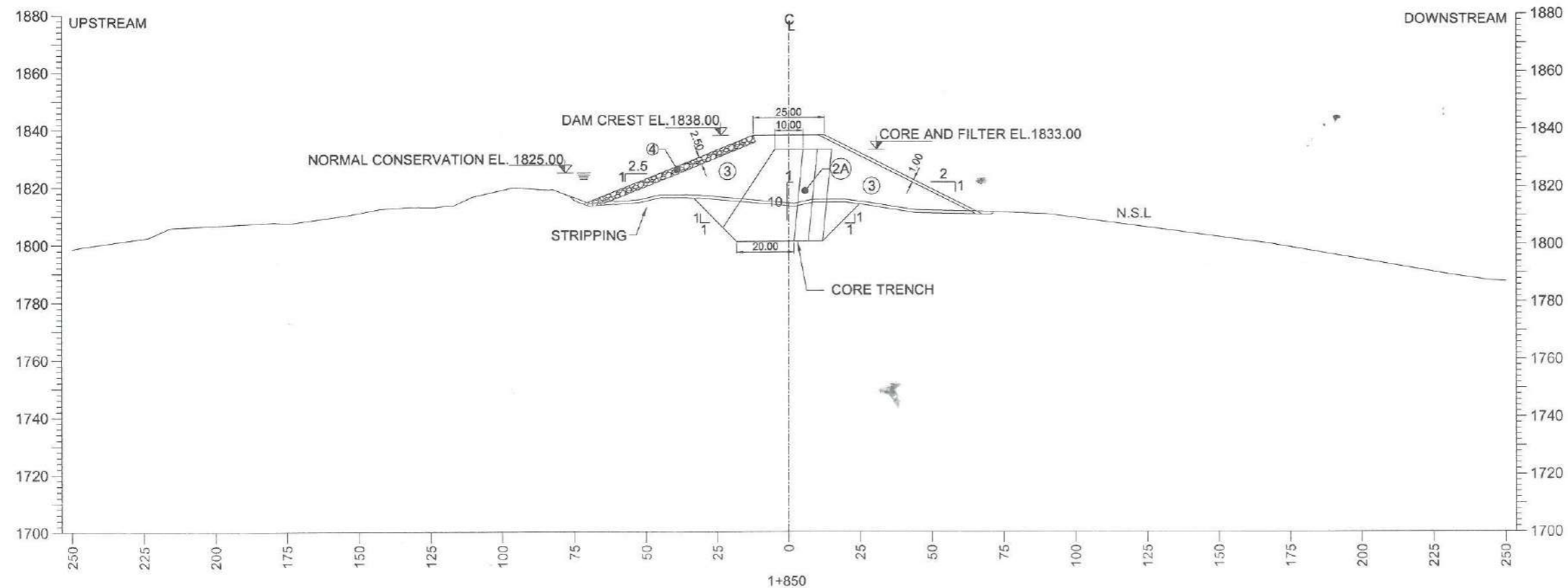
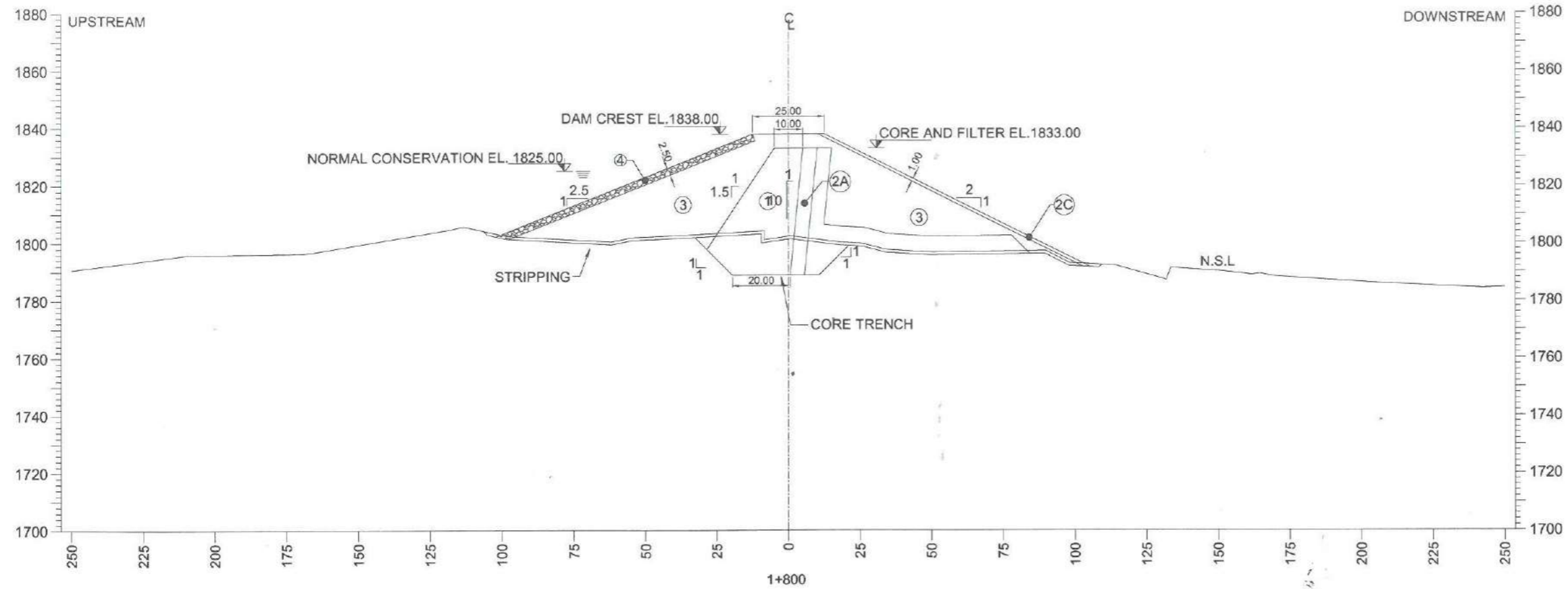

SHEET 19 OF 22



S. NO.	DATE	DESCRIPTIONS	CHECK
DIRECTORATE GENERAL SMALL DAMS IRRIGATION DEPARTMENT KHYBER PAKHTUNKHAWA			
SMALL DAM PROJECT			
SUMARI PAYAN DAM PROJECT DAM X-SECTIONS			
PAKISTAN ENGINEERING SERVICES (PVT.) LTD. 7 - B, COMMERCIAL AREA, PHASE - V, D.H.A., LAHORE.			
DESIGNED BY:	FAROOQ ALI	DATE:	DEC-2023
DESIGNED:	AHMED SHAHZAWAR	DRAWING NO.	
CHECKED:	ASHFAQ ALI		
APPROVED:	ADNAN MANZOOR	D-03	0

NOTES

ALL DIMENSIONS AND LEVELS ARE IN FEET.

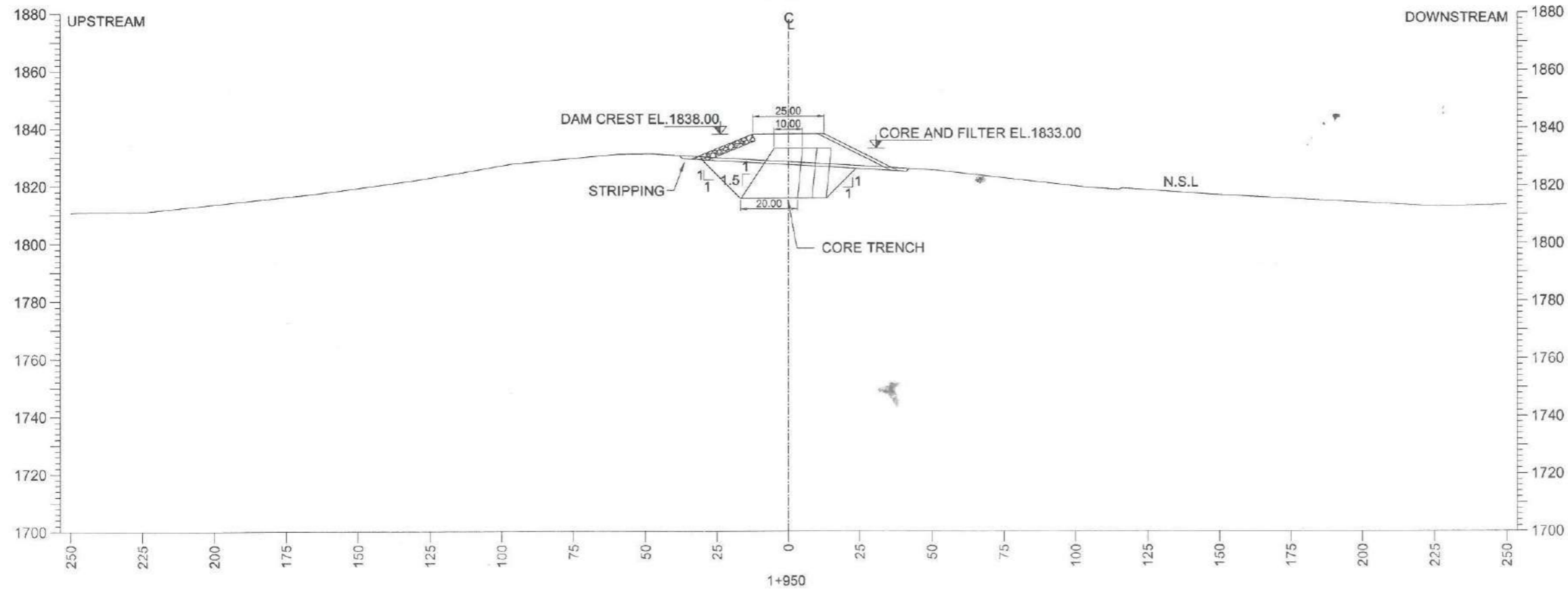
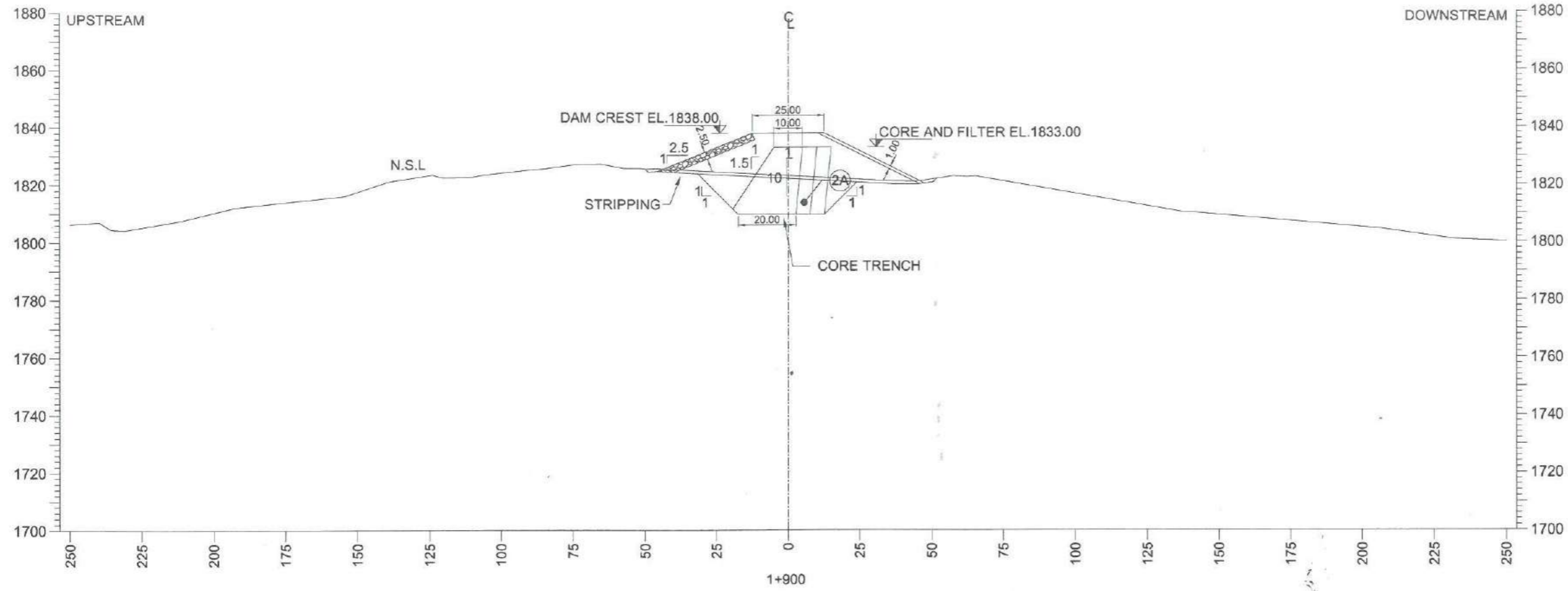

SHEET 20 OF 22



S.NO.	DATE	DESCRIPTIONS	CHECK
DIRECTORATE GENERAL SMALL DAMS IRRIGATION DEPARTMENT KHYBER PAKHTUNKHAWA			
SMALL DAM PROJECT			
SUMARI PAYAN DAM PROJECT DAM X-SECTIONS			
PAKISTAN ENGINEERING SERVICES (PVT.) LTD. 7 - B, COMMERCIAL AREA, PHASE - V, D.H.A., LAHORE.			
DESIGNED BY:	FAROOQ ALI	DATE:	DEC-2023
DESIGNED:	AHMED SHAHZAWAR	DRAWING NO.	
CHECKED:	ASHFAQ ALI		
APPROVED:	ADNAN MANZOOR	D-03	0

NOTES

ALL DIMENSIONS AND LEVELS ARE IN FEET.

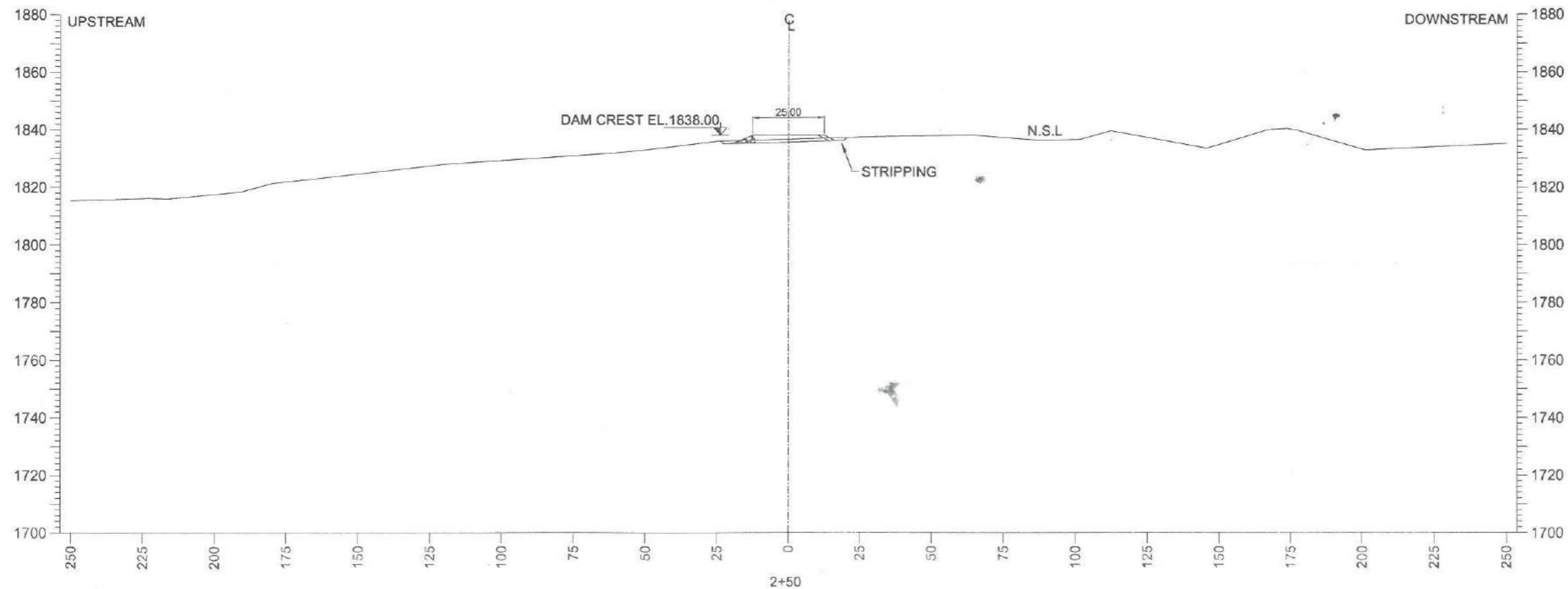
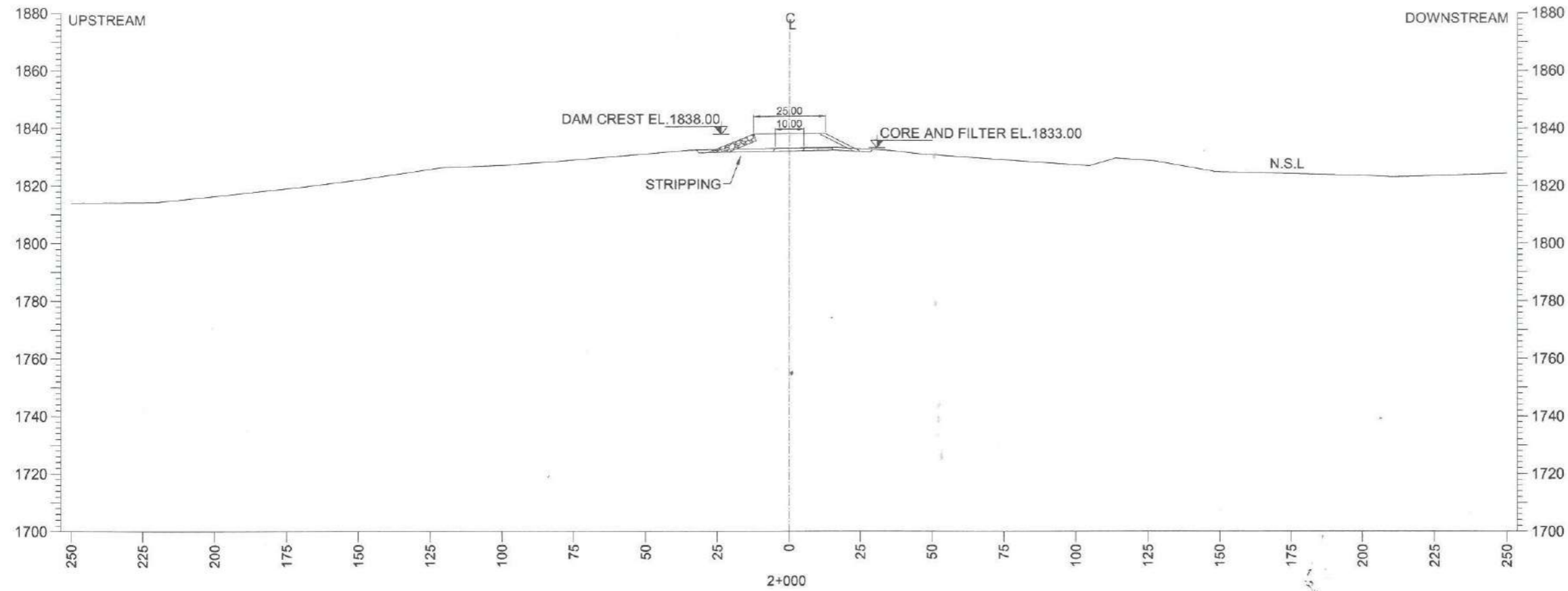

SHEET 21 OF 22



S.NO.	DATE	DESCRIPTIONS	CHECK
DIRECTORATE GENERAL SMALL DAMS IRRIGATION DEPARTMENT KHYBER PAKHTUNKHAWA			
SMALL DAM PROJECT			
SUMARI PAYAN DAM PROJECT DAM X-SECTIONS			
PAKISTAN ENGINEERING SERVICES (PVT.) LTD. 7 - B, COMMERCIAL AREA, PHASE - V, D.H.A. LAHORE.			
DESIGNED BY:	FAROOQ ALI	DATE:	DEC-2023
DESIGNED:	AHMED SHAHZAWAR	DRAWING NO.:	
CHECKED:	ASHFAQ ALI		
APPROVED:	ADNAN MANZOOR		
		REV. No.	0

NOTES

ALL DIMENSIONS AND LEVELS ARE IN FEET.

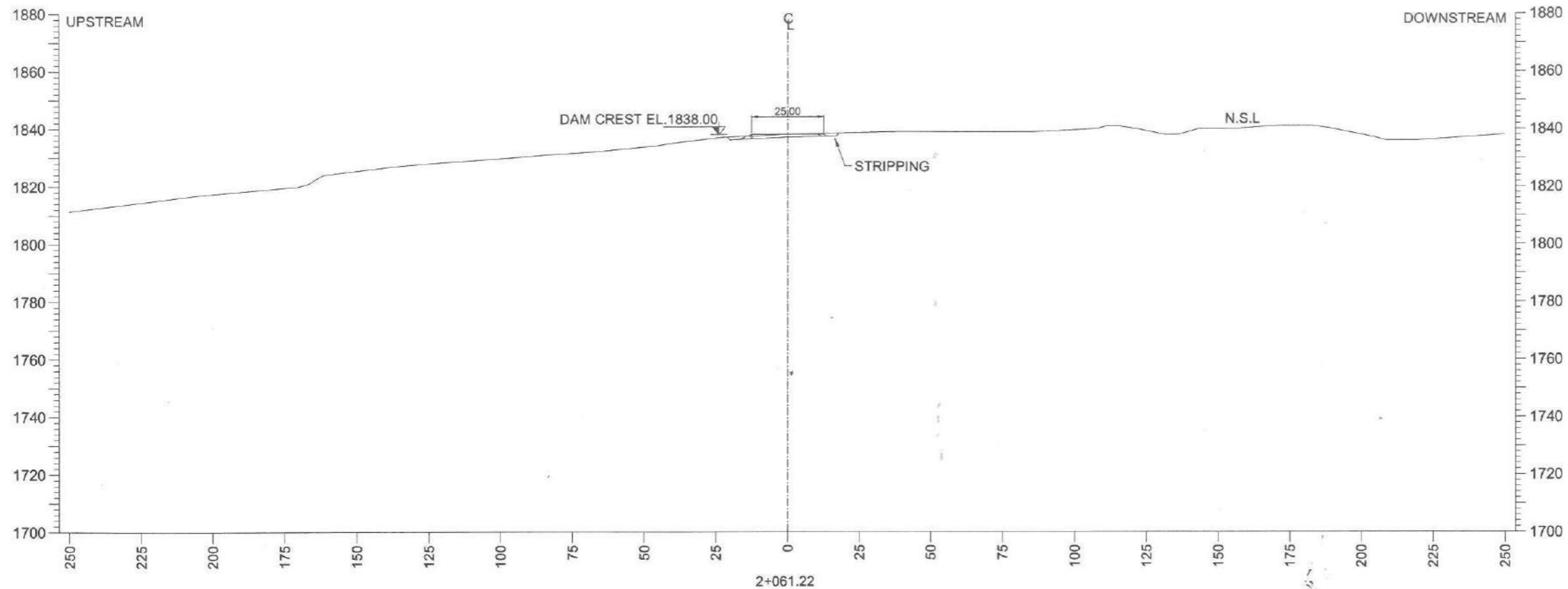

SHEET 22 OF 22



S.NO.	DATE	DESCRIPTIONS	CHECK
DIRECTORATE GENERAL SMALL DAMS IRRIGATION DEPARTMENT KHYBER PAKHTUNKHAWA			
SMALL DAM PROJECT			
SUMARI PAYAN DAM PROJECT DAM X-SECTIONS			
 PAKISTAN ENGINEERING SERVICES (PVT.) LTD. 7 - B, COMMERCIAL AREA, PHASE - V, D.H.A, LAHORE.			
DESIGNED BY:	FAROOQ ALI	DATE:	DEC-2023
DESIGNED BY:	AHMED SHAHZAWAR	DRAWING NO.	
CHECKED BY:	ASHFAQ ALI		
APPROVED BY:	ADNAN MANZOOR		
		D-03	0

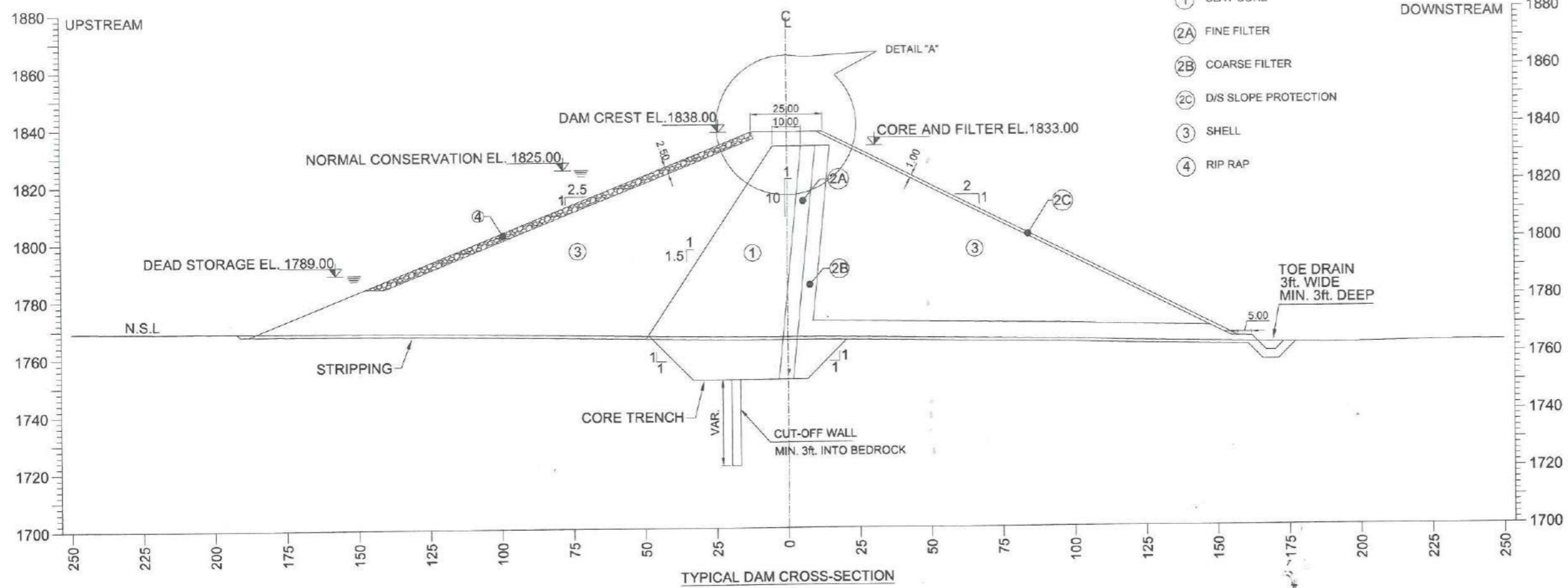

NOTES
ALL DIMENSIONS AND LEVELS ARE IN FEET.

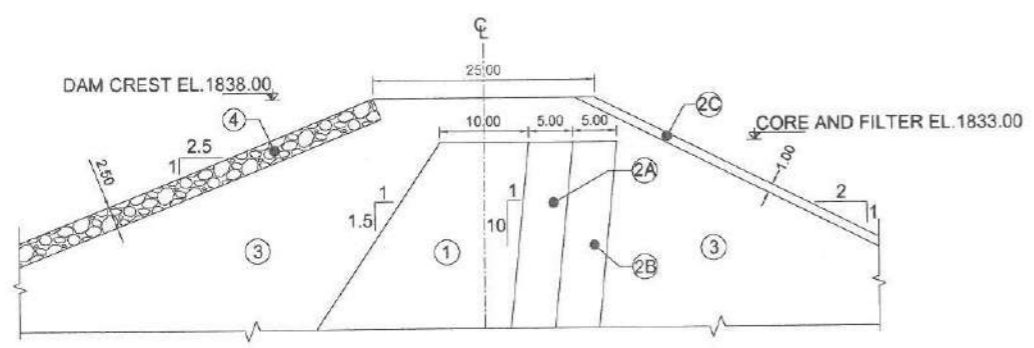

S. NO.	DATE	DESCRIPTIONS	CHECK
DIRECTORATE GENERAL SMALL DAMS IRRIGATION DEPARTMENT KHYBER PAKHTUNKHAWA			
SMALL DAM PROJECT			
SUMARI PAYAN DAM PROJECT DAM TYPICAL SECTION AND DETAIL			
 PAKISTAN ENGINEERING SERVICES (PVT.) LTD. 7 - B, COMMERCIAL AREA, PHASE - V, D.H.A, LAHORE.			
DESIGNED BY:	FAROOQ ALI	DATE:	DEC-2023
DESIGNED BY:	AHMED SHAHZAWAR	DRAWING NO.	
CHECKED BY:	ASHFAQ ALI		D-03
APPROVED BY:	ADNAN MANZOOR		0

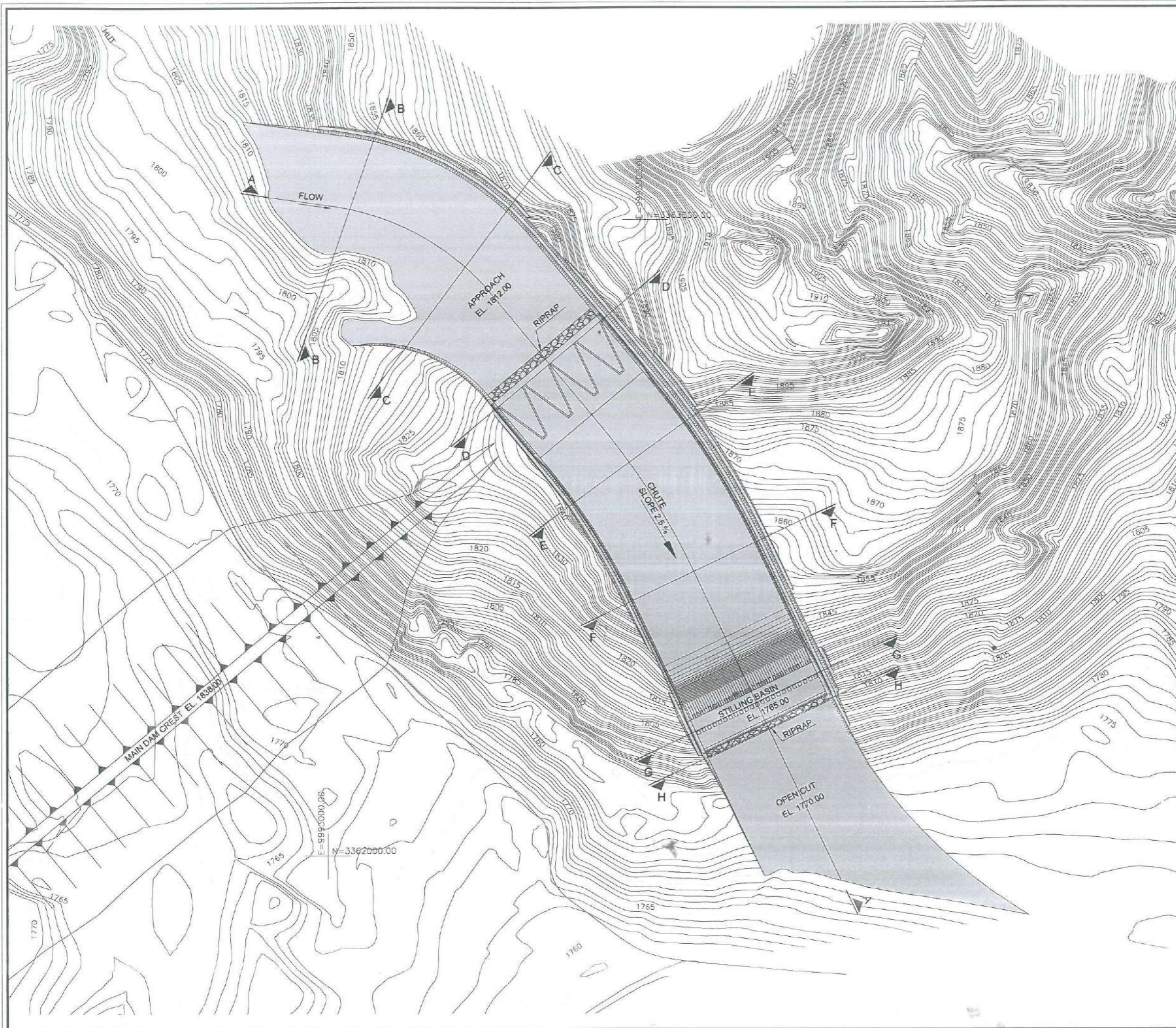

- NOTES**
1. ALL DIMENSIONS AND LEVELS ARE IN FEET
- REFERENCES**
1. FOR GENERAL LAYOUT PLAN SEE DWG. NO. GEN-01
 2. FOR L-SECTION SEE DWG. NO. 6.2
 3. FOR X-SECTION SEE DWG. NO. 6.3 & 6.5 TO 6.7
 4. FOR LABYRINTH PLAN & SECTION DWG. NO. 6.4



S.NO.	DATE	DESCRIPTIONS	CHECK
DIRECTORATE GENERAL SMALL DAMS IRRIGATION DEPARTMENT KHYBER PAKHTUNKHAWA			
SMALL DAM PROJECT			
SUMARI PAYAN DAM PROJECT			
SPILLWAY LAYOUT PLAN			
PAKISTAN ENGINEERING SERVICES (PVT.) LTD. 7 - B, COMMERCIAL AREA, PHASE - V, D.H.A. LAHORE.			
DESIGNED BY:	MOHSIN AHMAD	DATE:	JUNE 2009
DESIGNED BY:	SHAHBAZ BUTT	REV. No.	
CHECKED BY:	SIBT UL HASSAN NAQVI	DRAWING NO.	
APPROVED BY:	SIBT UL HASSAN NAQVI	6.1	

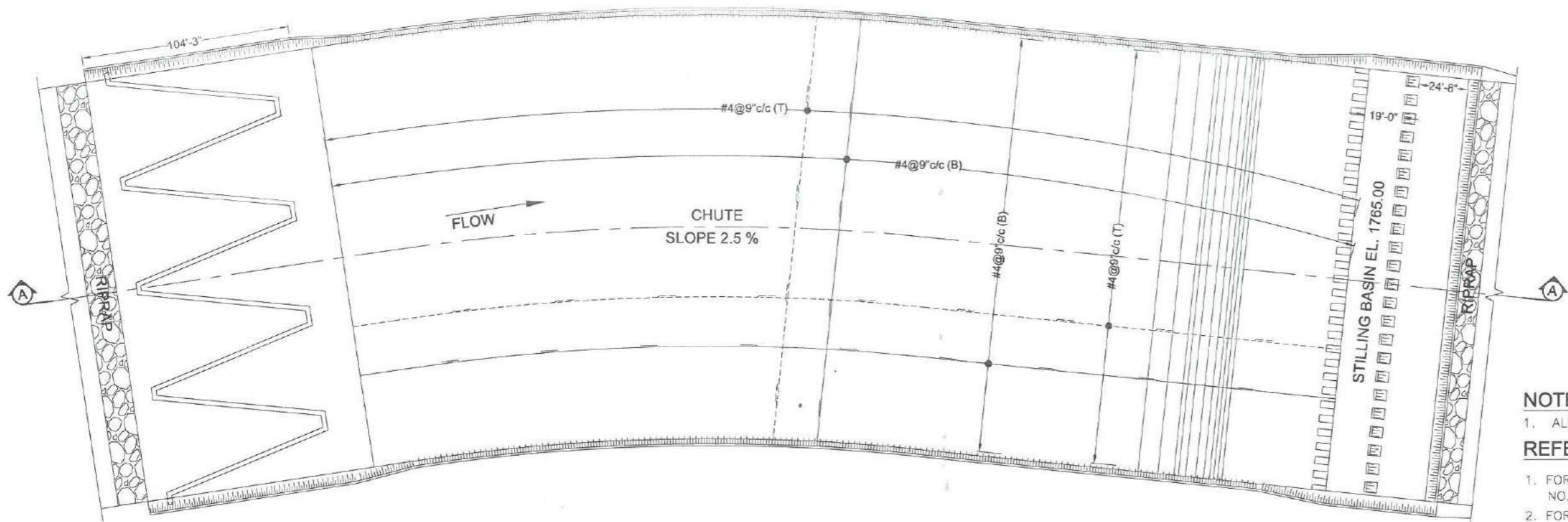

SPILLWAY PLAN

NOTES

1. ALL DIMENSIONS AND LEVELS ARE IN FEET

REFERENCES

1. FOR GENERAL LAYOUT PLAN SEE DWG. NO. GEN-01
2. FOR SPILLWAY LAYOUT PLAN SEE DWG. NO. 6.1
3. FOR X-SECTION SEE DWG. NO. 6.3 & 6.5 TO 6.7
4. FOR LABYRINTH PLAN & SECTION DWG. NO. 6.4

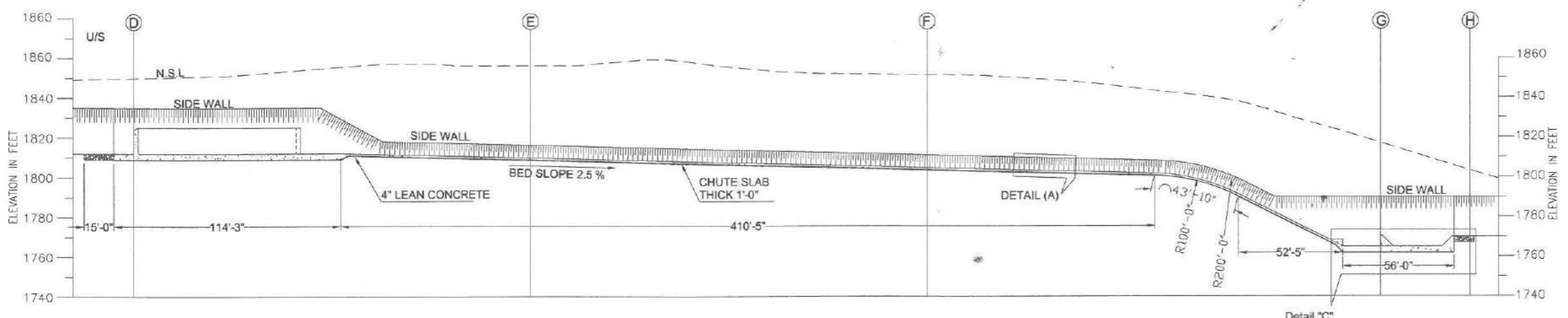

SECTION A-A

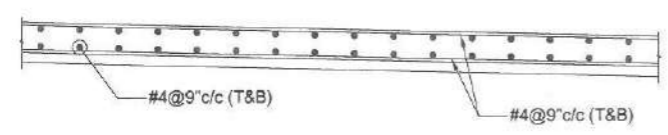

DETAIL (A)

S.NO.	DATE	DESCRIPTIONS	CHECK
SMALL DAMS ORGANIZATION, IRRIGATION DEPARTMENT			
SMALL DAM PROJECT			
SUMARI PAYAN SPILLWAY PLAN AND L-SECTION REINFORCEMENT DETAIL			
 PAKISTAN ENGINEERING SERVICES (PVT.) LTD. 188 - Y, COMMERCIAL AREA, PHASE - III, D.H.A, LAHORE.			
DRAWN:	MOHSIN AHMAD	DATE: JUNE 2009	REV. No.
DESIGNED:	SHAHBAZ BUTT	DRAWING NO.	
CHECKED:	SIBT UL HASSAN NAQVI	6.2	
APPROVED:	SIBT UL HASSAN NAQVI		

NOTES

1. ALL DIMENSIONS AND LEVELS ARE IN FEET

REFERENCES

1. FOR GENERAL LAYOUT PLAN SEE DWG. NO. GEN-01
2. FOR SPILLWAY LAYOUT PLAN SEE DWG. NO. 6.1
3. FOR X-SECTION SEE DWG. NO. 6.5 TO 6.7
4. FOR LABYRINTH PLAN & SECTION DWG. NO. 6.4

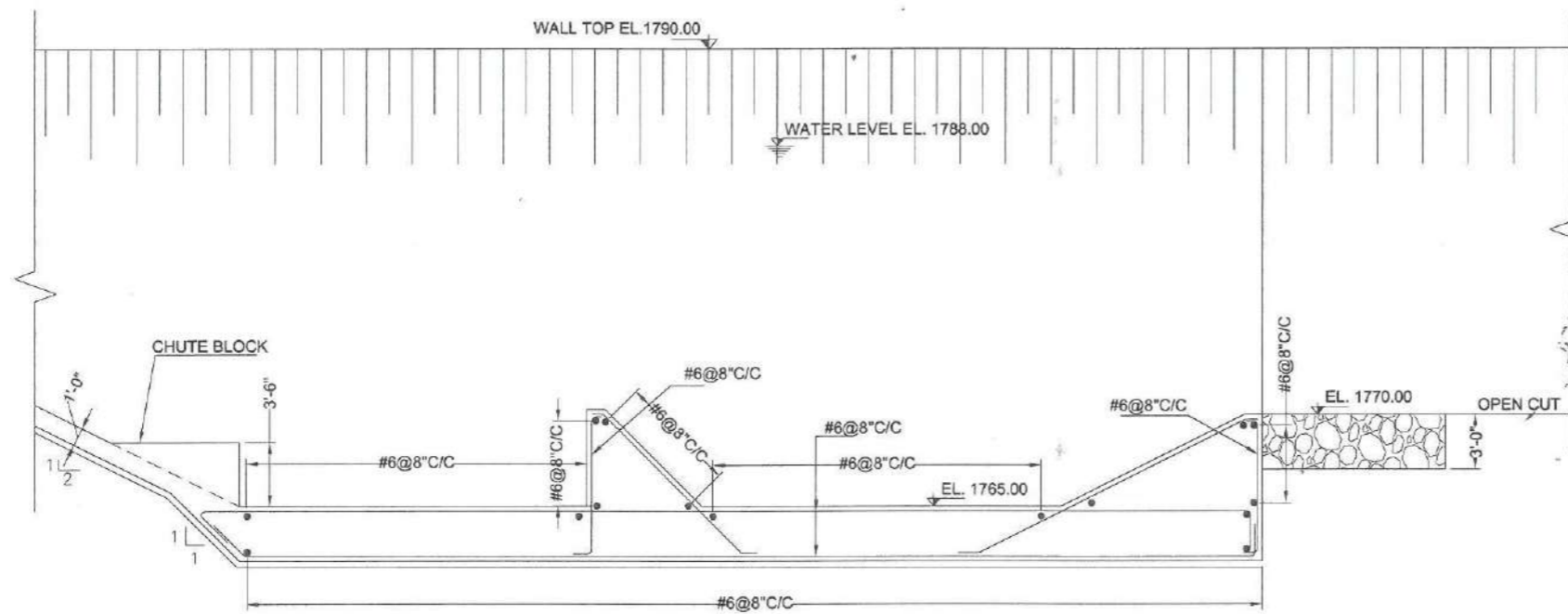

DETAIL C
STILLING BASIN



S. NO.	DATE	DESCRIPTIONS	CHECK
SMALL DAMS ORGANIZATION, IRRIGATION DEPARTMENT			
SMALL DAM PROJECT			
SUMARI PAYAN SPILLWAY STILLING BASIN DETAIL			
 PAKISTAN ENGINEERING SERVICES (PVT.) LTD. 188 -Y, COMMERCIAL AREA, PHASE-III, D.H.A. LAHORE.			
DRAWN:	MOHSIN AHMAD	DATE: JUNE 2009	REV. No.
DESIGNED:	SHAHBAZ BLITT	DRAWING NO.	
CHECKED:	SIBT UL HASSAN NAQVI	6.3	
APPROVED:	SIBT UL HASSAN NAQVI		

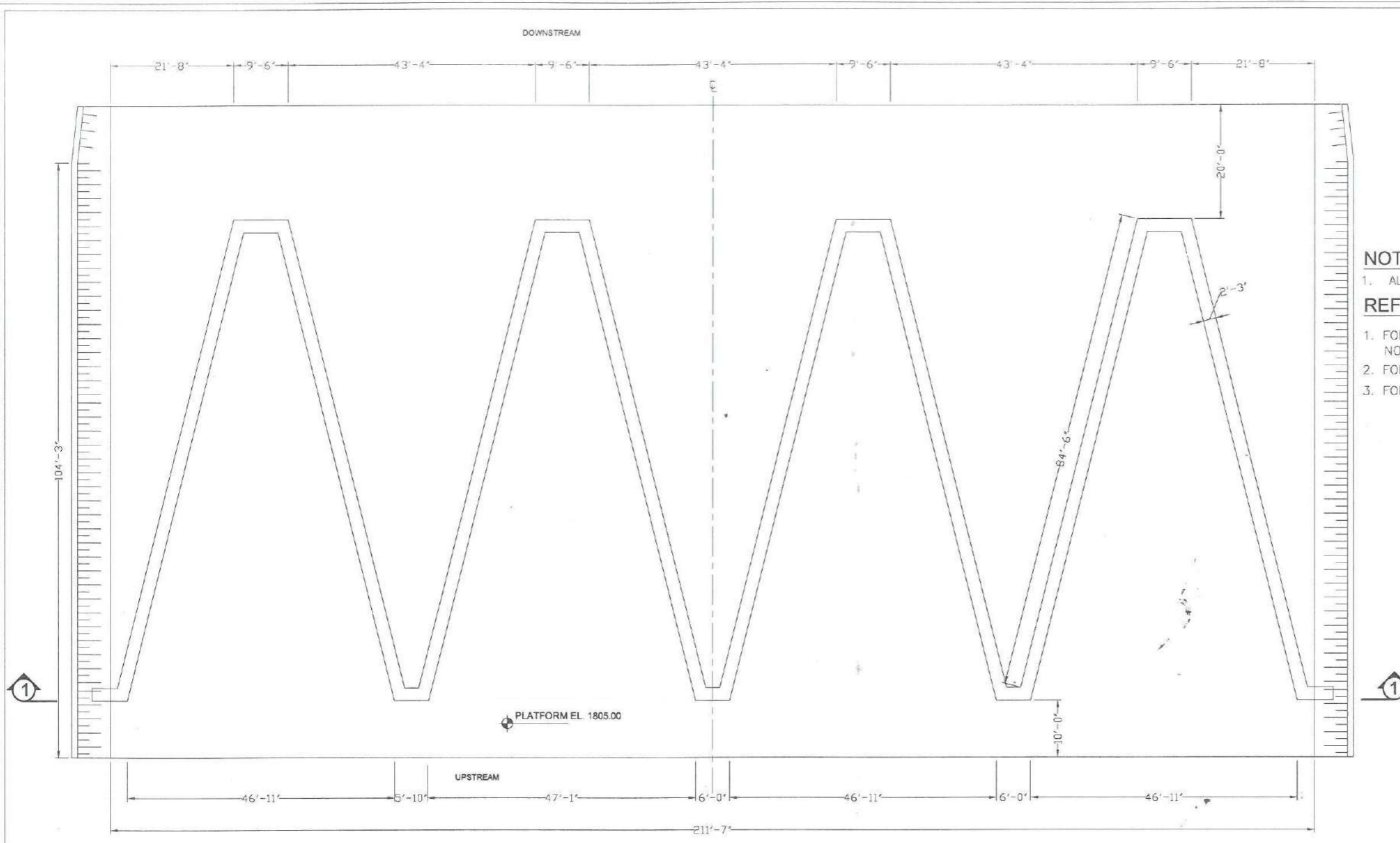

PLAN

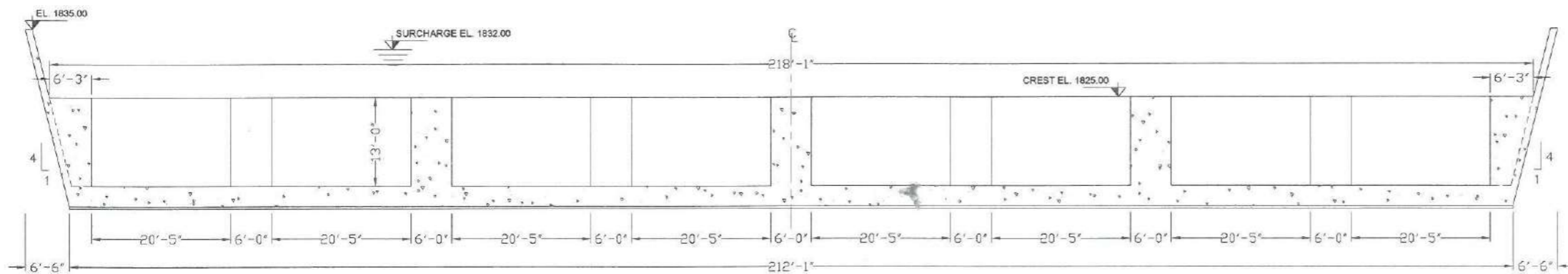

SECTION A-A

NOTES

1. ALL DIMENSIONS AND LEVELS ARE IN FEET

REFERENCES

1. FOR GENERAL LAYOUT PLAN SEE DWG. NO. GEN-01
2. FOR SPILLWAY LAYOUT PLAN SEE DWG. NO. 6.1
3. FOR X-SECTIONS SEE DWG. NO.6.3, 6.5 TO 6.7

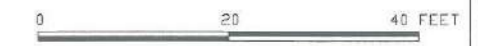

S.NO.	DATE	DESCRIPTIONS	CHECK
SMALL DAMS ORGANIZATION, IRRIGATION DEPARTMENT			
SMALL DAM PROJECT			
SUMARI PAYAN SPILLWAY LABYRINTH PLAN & SECTION			
PAKISTAN ENGINEERING SERVICES (PVT.) LTD. 188 -Y, COMMERCIAL AREA, PHASE-III, D.H.A. LAHORE.			
DRAWN:	MOHSIN AHMAD	DATE: JUNE 2009	REV. No.
DESIGNED:	SHAHBAZ BUTT	DRAWING NO.	
CHECKED:	SIBT UL HASSAN NAQVI	6.4	
APPROVED:	SIBT UL HASSAN NAQVI		

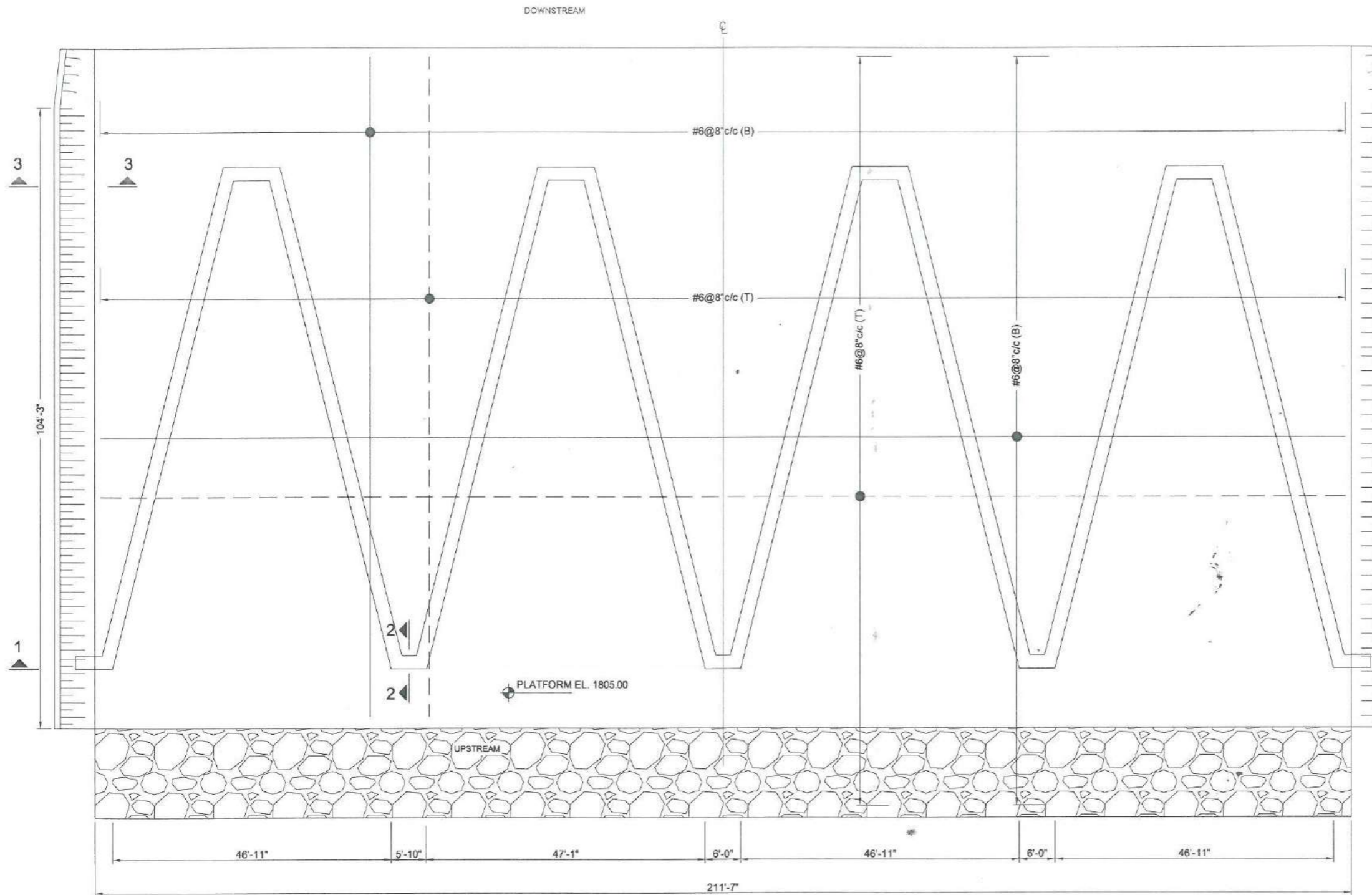

REINFORCEMENT PLAN

NOTES

1. ALL DIMENSIONS AND LEVELS ARE IN FEET

REFERENCES

1. FOR GENERAL LAYOUT PLAN SEE DWG. NO. GEN-01
2. FOR SPILLWAY LAYOUT PLAN SEE DWG. NO. 6.1
3. FOR X-SECTIONS SEE DWG. NO.6.3, 6.5 TO 6.7



S.NO.	DATE	DESCRIPTIONS	CHECK
SMALL DAMS ORGANIZATION, IRRIGATION DEPARTMENT			
SMALL DAM PROJECT			
SUMARI PAYAN SPILLWAY LABYRINTH PLAN REINFORCEMENT			
PAKISTAN ENGINEERING SERVICES (PVT.) LTD. 188 -Y, COMMERCIAL AREA, PHASE-II, D.H.A. LAHORE.			
DRAWN:	MOHSIN AHMAD	DATE: JUNE 2009	REV. No.
DESIGNED:	SHAMBAZ BUTT	DRAWING NO.	
CHECKED:	SIBT UL HASSAN NAQVI	6.4	
APPROVED:	SIBT UL HASSAN NAQVI		

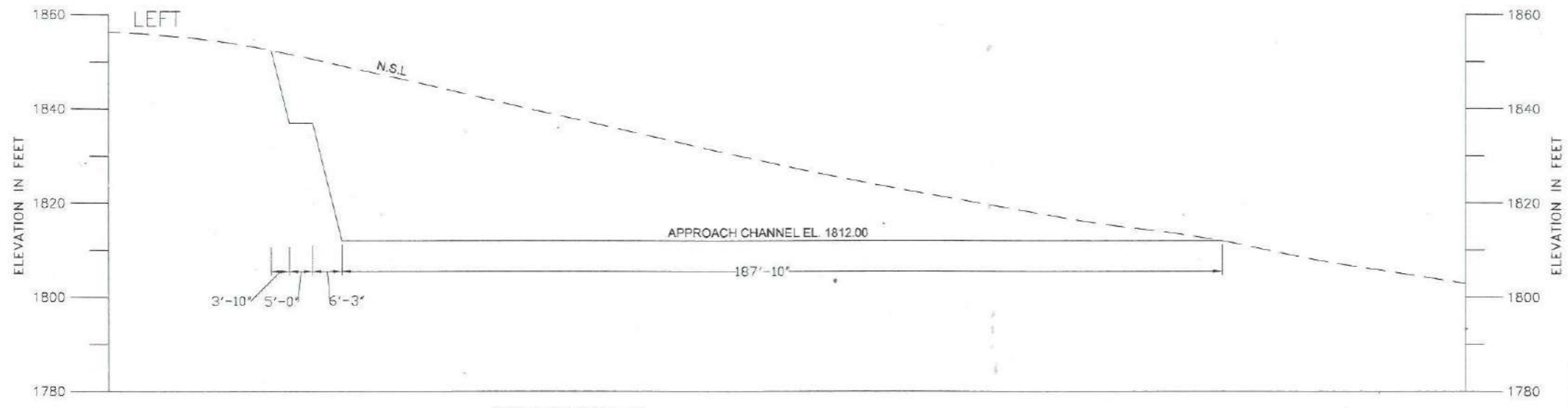

SECTION B-B

NOTES

1. ALL DIMENSIONS AND LEVELS ARE IN FEET

REFERENCES

1. FOR GENERAL LAYOUT PLAN SEE DWG. NO. GEN-01
2. FOR SPILLWAY LAYOUT PLAN SEE DWG. NO. 6.1
3. FOR X-SECTION SEE DWG. NO. 6.3, 6.4, 6.6 & 6.7
4. FOR LABYRINTH PLAN & SECTION DWG. NO. 6.4

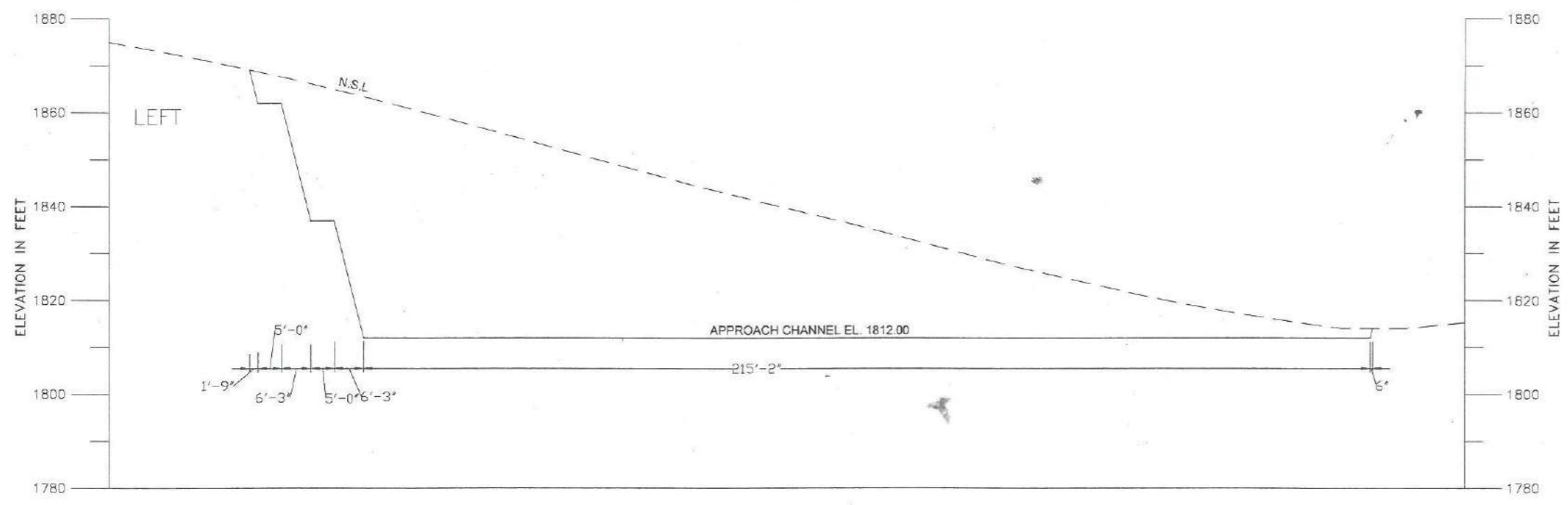

SECTION C-C



SMALL DAMS ORGANIZATION, IRRIGATION DEPARTMENT			
SMALL DAM PROJECT			
SUMARI PAYAN SPILLWAY X-SECTIONS B-B & C-C			
 PAKISTAN ENGINEERING SERVICES (PVT.) LTD. 188 -Y, COMMERCIAL AREA, PHASE-II, D.H.A. LAHORE.			
DRAWN:	MOHSIN AHMAD	DATE: JUNE 2006	REV. No.
DESIGNED:	SHAHBAZ BUTT	DRAWING NO.	
CHECKED:	SIBT UL HASSAN NAQVI	6.5	
APPROVED:	SIBT UL HASSAN NAQVI		

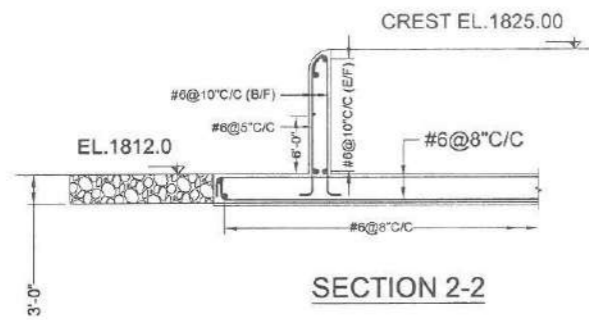

SECTION 2-2

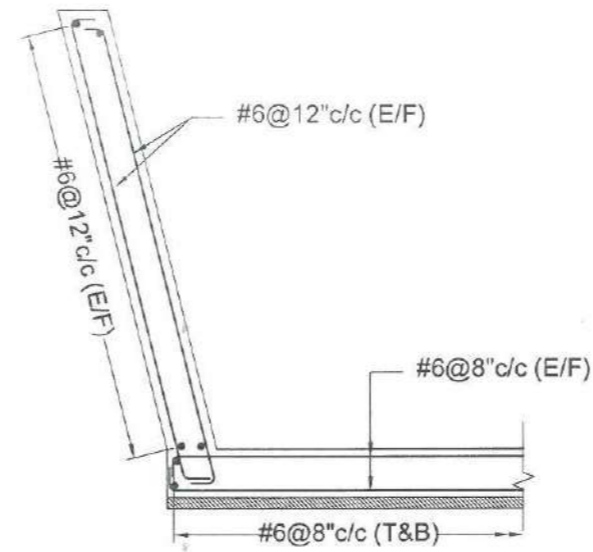

SECTION 3-3

NOTES

1. ALL DIMENSIONS AND LEVELS ARE IN FEET

REFERENCES

1. FOR GENERAL LAYOUT PLAN SEE DWG. NO. GEN-01
2. FOR SPILLWAY LAYOUT PLAN SEE DWG. NO. 6.1
3. FOR X-SECTIONS SEE DWG. NO.6.3, 6.5 TO 6.7

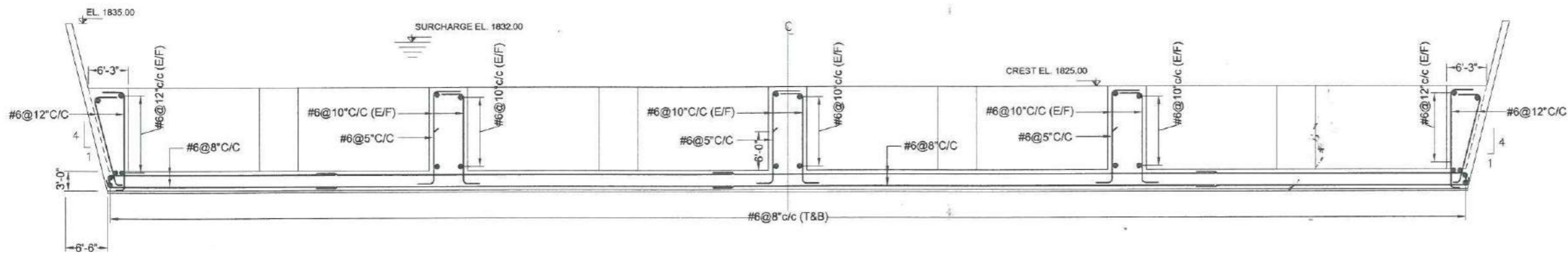

SECTION 1-1



S.NO.	DATE	DESCRIPTIONS	CHECK
SMALL DAMS ORGANIZATION, IRRIGATION DEPARTMENT			
SMALL DAM PROJECT			
SUMARI PAYAN SPILLWAY LABYRINTH SECTION REINFORCEMENT			
PAKISTAN ENGINEERING SERVICES (PVT.) LTD. 188 -Y, COMMERCIAL AREA, PHASE-III, D.H.A. LAHORE.			
DRAWN:	MCHSIN AHMAD	DATE: JUNE 2009	REV. No.
DESIGNED:	SHAHBAZ BUTT	DRAWING NO.	
CHECKED:	SIBT UL HASSAN NAOMI	6.4	
APPROVED:	SIBT UL HASSAN NAOMI		

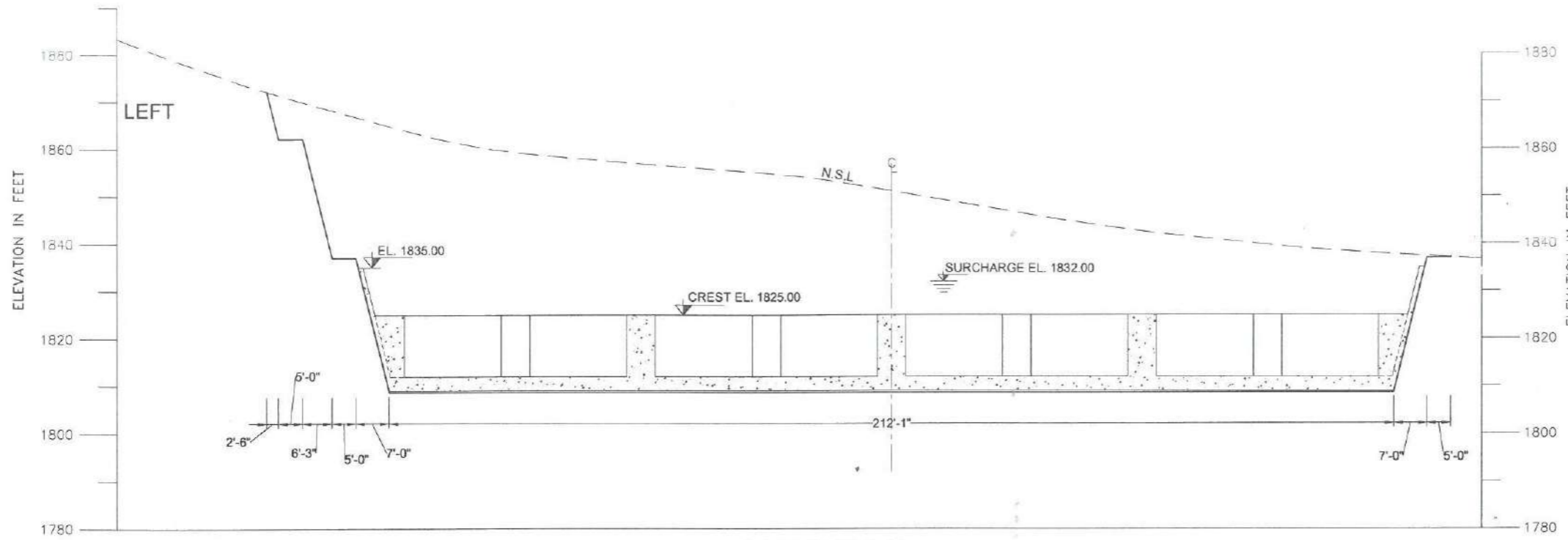

SECTION D-D

NOTES

1. ALL DIMENSIONS AND LEVELS ARE IN FEET

REFERENCES

1. FOR GENERAL LAYOUT PLAN SEE DWG. NO. GEN-01
2. FOR SPILLWAY LAYOUT PLAN SEE DWG. NO. 6.1
3. FOR X-SECTION SEE DWG. NO. 6.3 TO 6.5 & 6.7
4. FOR LABYRINTH PLAN & SECTION DWG. NO. 6.4

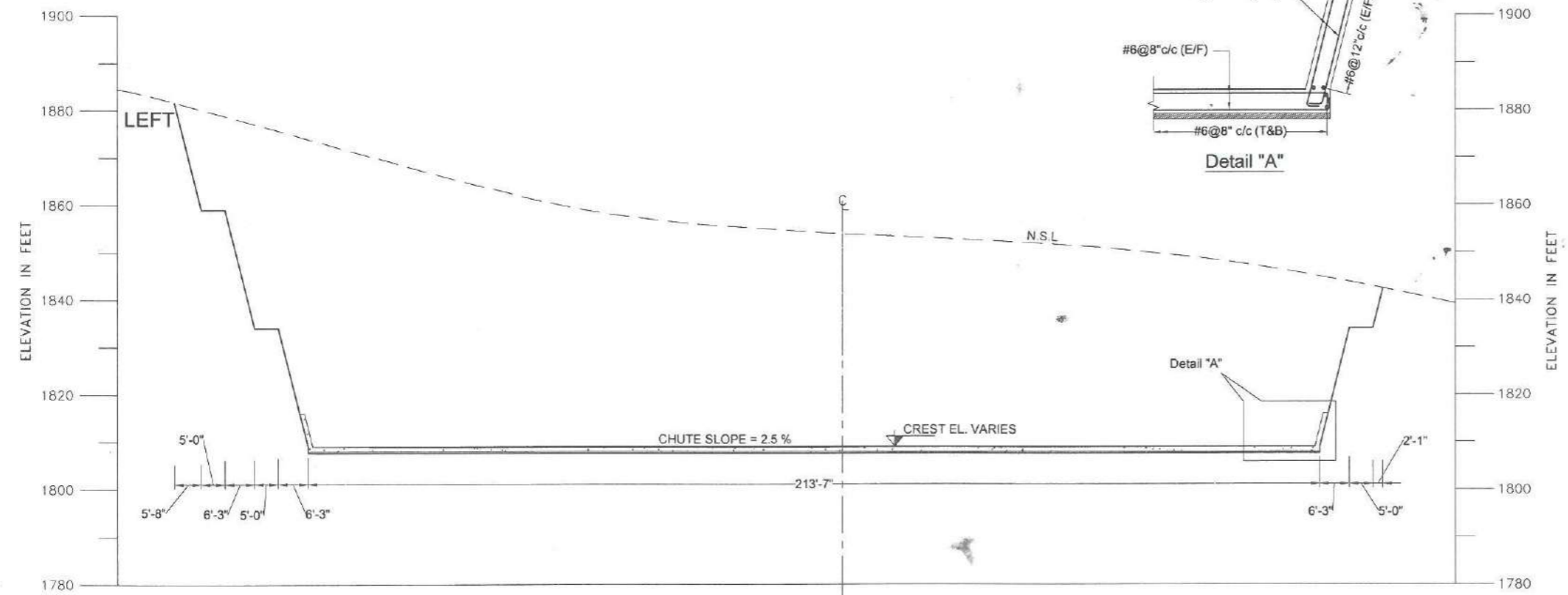

SECTION E-E

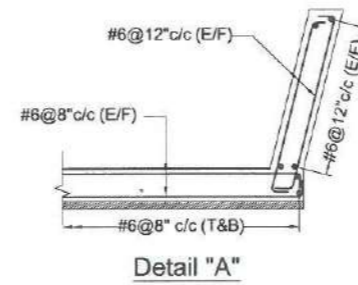

Detail "A"



S.NO.	DATE	DESCRIPTIONS	CHECK
SMALL DAMS ORGANIZATION, IRRIGATION DEPARTMENT			
SMALL DAM PROJECT			
SUMARI PAYAN DAM SPILLWAY X-SECTIONS D-D & E-E			
 PAKISTAN ENGINEERING SERVICES (PVT.) LTD. 188 -Y, COMMERCIAL AREA, PHASE-III, D.H.A. LAHORE.			
DRAWN:	MOHSIN AHMAD	DATE: JUNE 2009	REV. No.
DESIGNED:	SHAHBAZ BUTT	DRAWING NO.	
CHECKED:	SIBT UL HASSAN NAQVI	6.6	
APPROVED:	SIBT UL HASSAN NAQVI		

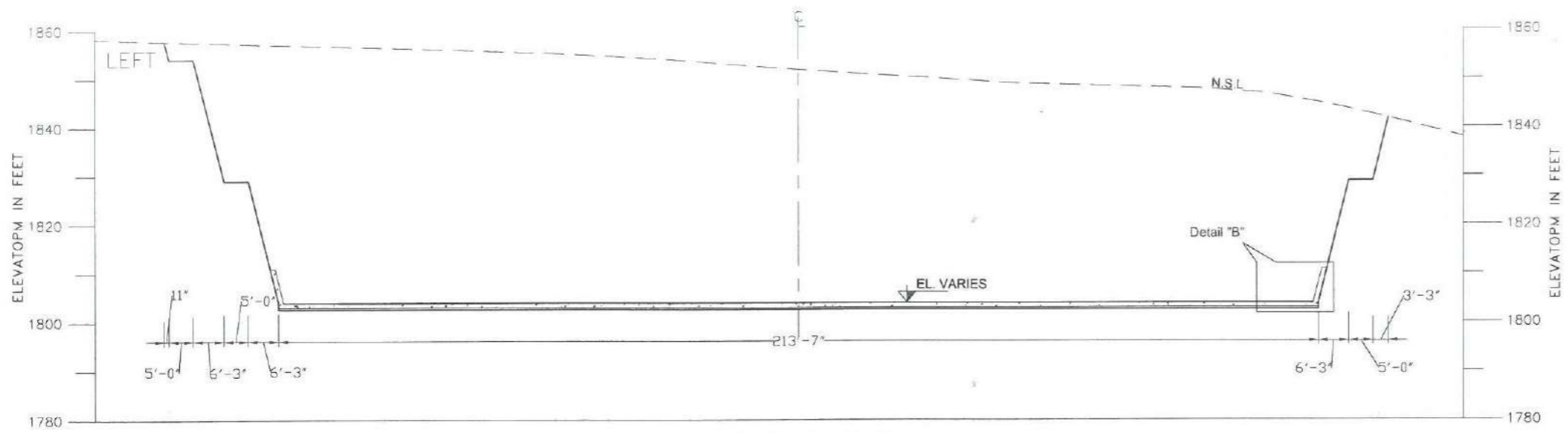

SECTION F-F

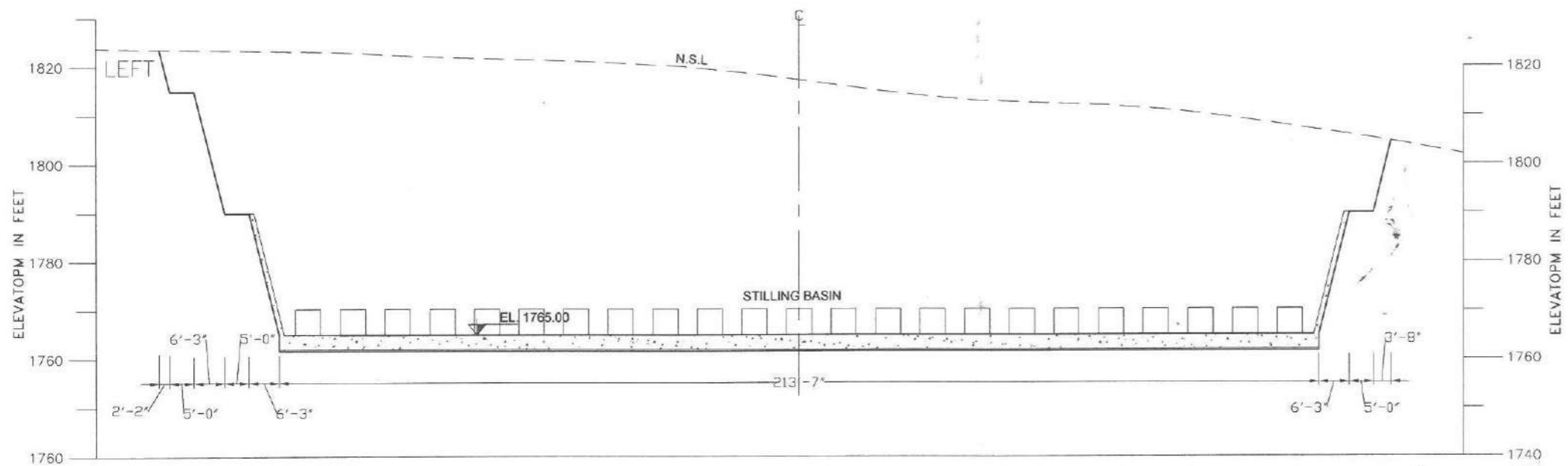

SECTION G-G

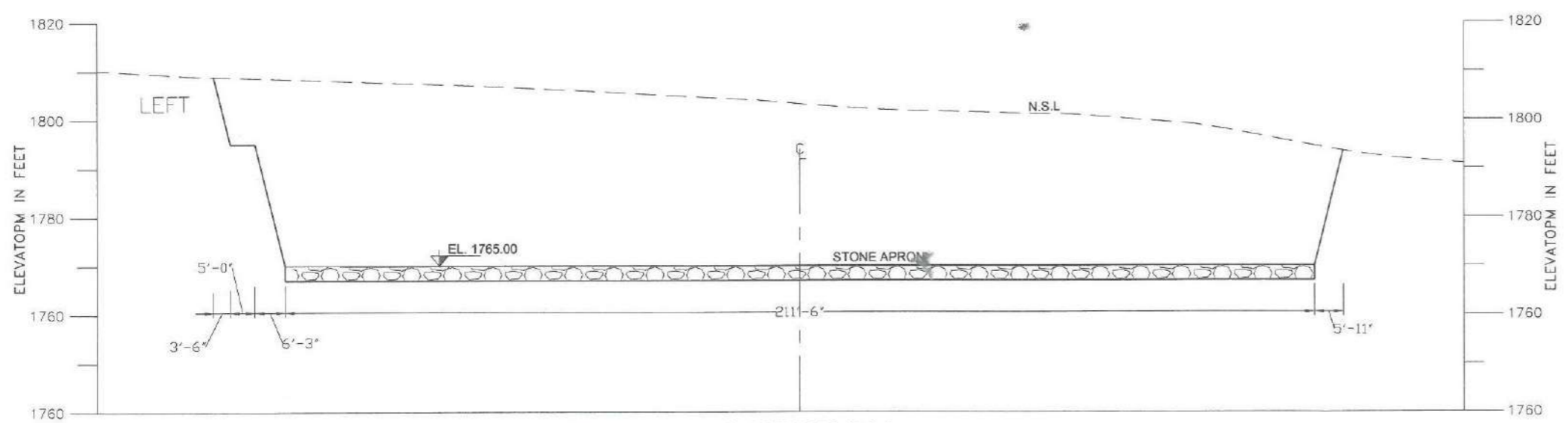

SECTION H-H

NOTES

1. ALL DIMENSIONS AND LEVELS ARE IN FEET

REFERENCES

1. FOR GENERAL LAYOUT PLAN SEE DWG. NO. GEN-01
2. FOR SPILLWAY LAYOUT PLAN SEE DWG. NO. 6.1
3. FOR X-SECTION SEE DWG. NO. 6.3 TO 6.6
4. FOR LABYRINTH PLAN & SECTION DWG. NO. 6.4

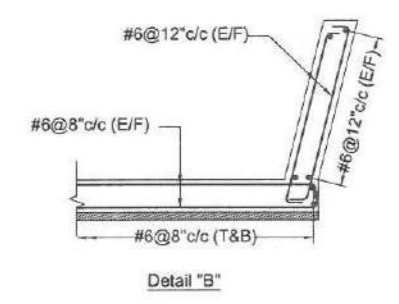

S. NO.	DATE	DESCRIPTIONS	CHECK
SMALL DAMS ORGANIZATION, IRRIGATION DEPARTMENT			
SMALL DAM PROJECT			
SUMARI PAYAN DAM SPILLWAY X-SECTIONS F-F, G-G & H-H			
PAKISTAN ENGINEERING SERVICES (PVT.) LTD. 188 -Y, COMMERCIAL AREA, PHASE-III, D.H.A, LAHORE.			
DRAWN:	MOHAMMAD AHMAD	DATE: JUNE 2009	REV. No.
DESIGNED:	SHAHBAZ BUITT	DRAWING NO.	
CHECKED:	SIBT UL HASSAN NAQVI	6.7	
APPROVED:	SIBT UL HASSAN NAQVI		

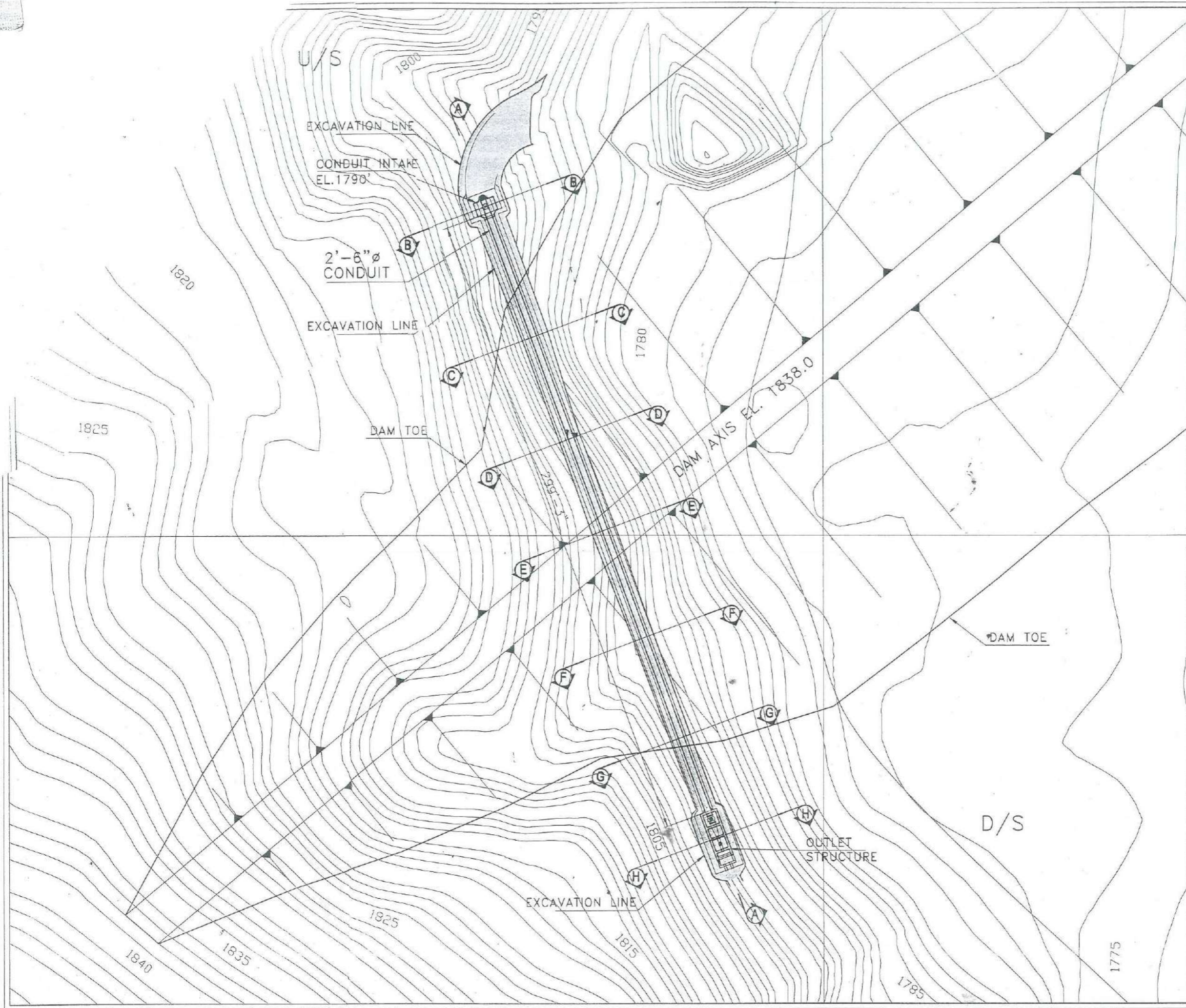

REFERENCE DRAWINGS

- 1. FOR CONDUIT SECTIONS AND DETAILS SEE DWG. NO. SDP-CON-7.2 TO 7.8

NOTE

ALL DIMENSIONS AND LEVELS ARE IN FEET.



S.NO.	DATE	DESCRIPTIONS	CHECK

SMALL DAMS ORGANIZATION, IRRIGATION DEPARTMENT

SMALL DAM PROJECT

SUMARI PAYAN DAM
CONDUIT LAYOUT PLAN

PKES PAKISTAN ENGINEERING SERVICES (PVT.) LTD.
188 -Y, COMMERCIAL AREA, PHASE -III
D.H.A. LAHORE.

DRAWN:	ZAHID RANA	DATE:	JUNE 2009	REV. No.	
DESIGNED:	ZESHAN	DRAWING NO.			
CHECKED:	D.K. KIRMANI				
APPROVED:	SIBT UL HASSAN NAQVI				

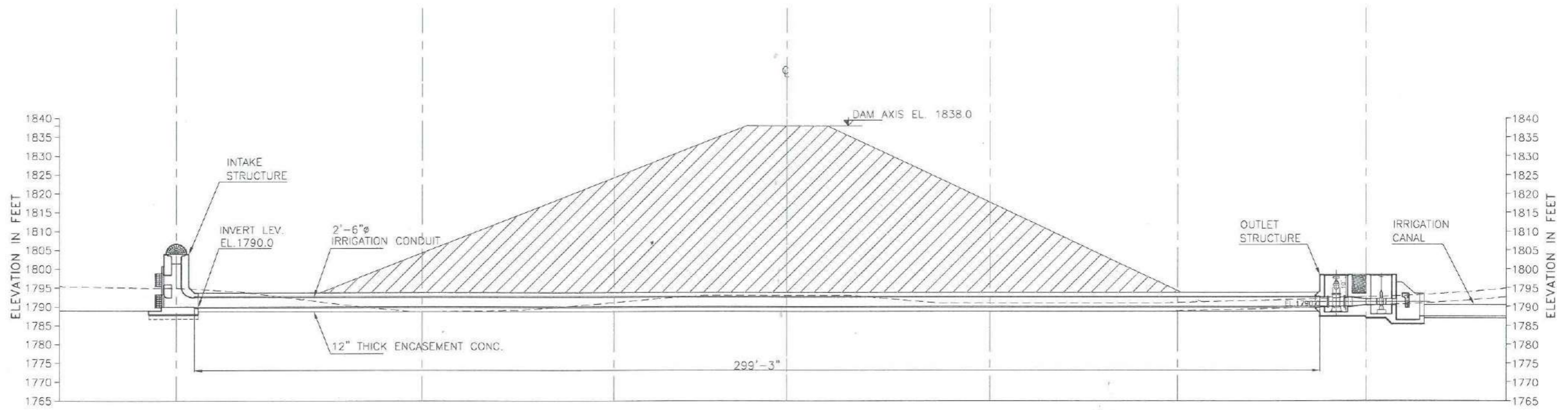

LONGITUDINAL SECTION A-A

REFERENCE DRAWINGS

1. FOR CONDUIT LAYOUT PLAN SEE DWG. NO. 7.1
2. FOR X-SECTIONS SEE DWG. NO. 7.3 TO 7.8

NOTE

1. ALL DIMENSIONS AND LEVELS ARE IN FEET.

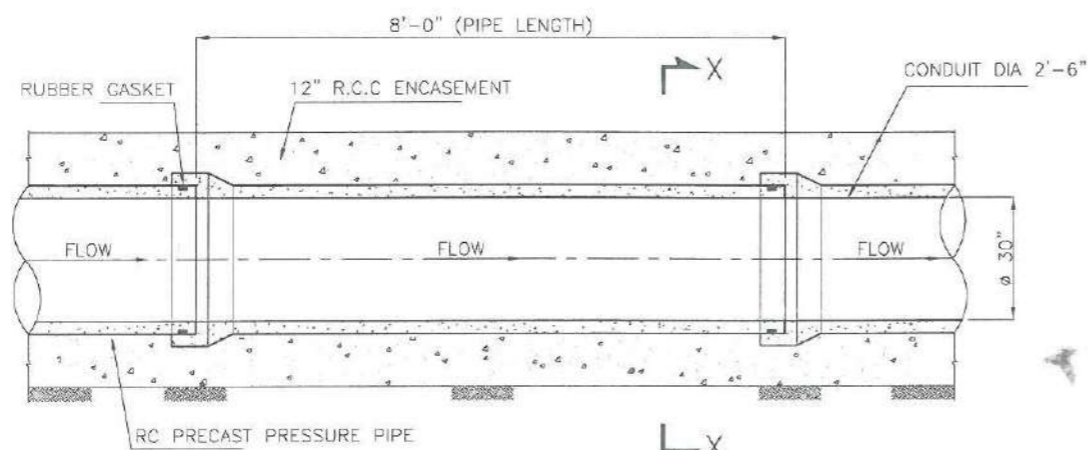

IRRIGATION CONDUIT DETAIL (TYP.)

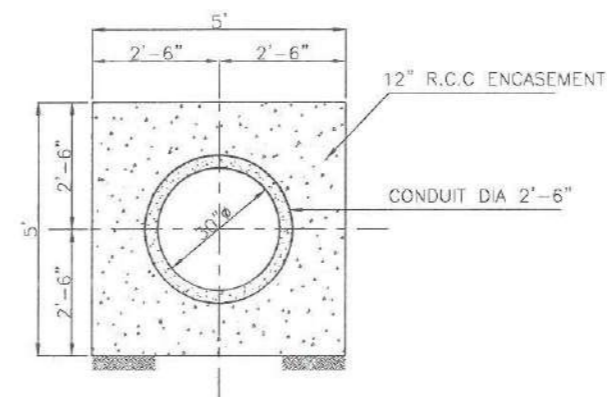

SECTION X-X

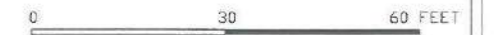

S. NO.	DATE	DESCRIPTIONS	CHECK
SMALL DAMS ORGANIZATION, IRRIGATION DEPARTMENT			
SMALL DAM PROJECT			
SUMARI PAYAN DAM CONDUIT LONGITUDINAL SECTION			
PAKISTAN ENGINEERING SERVICES (PVT.) LTD. 188 -Y, COMMERCIAL AREA, PHASE-III, D.H.A. LAHORE.			
DRAWN:	ZAHID RANA	DATE: JUNE 2009	REV. No.
DESIGNED:	ZESHAN	DRAWING NO.	
CHECKED:	D.K. KHURAM	7.2	
APPROVED:	SIBT UL HASSAN NAQVI		

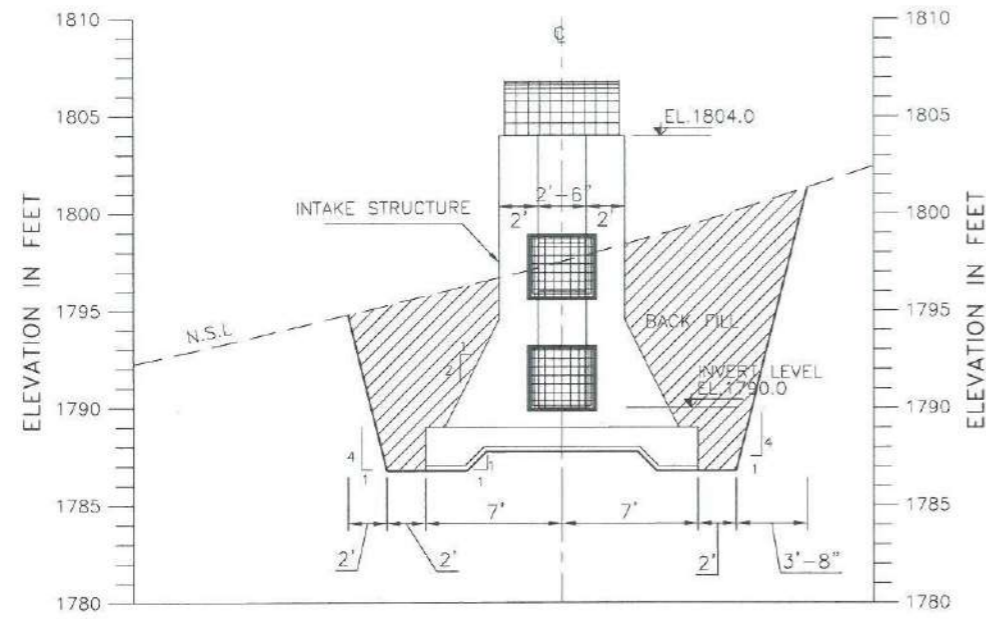

SECTION B-B

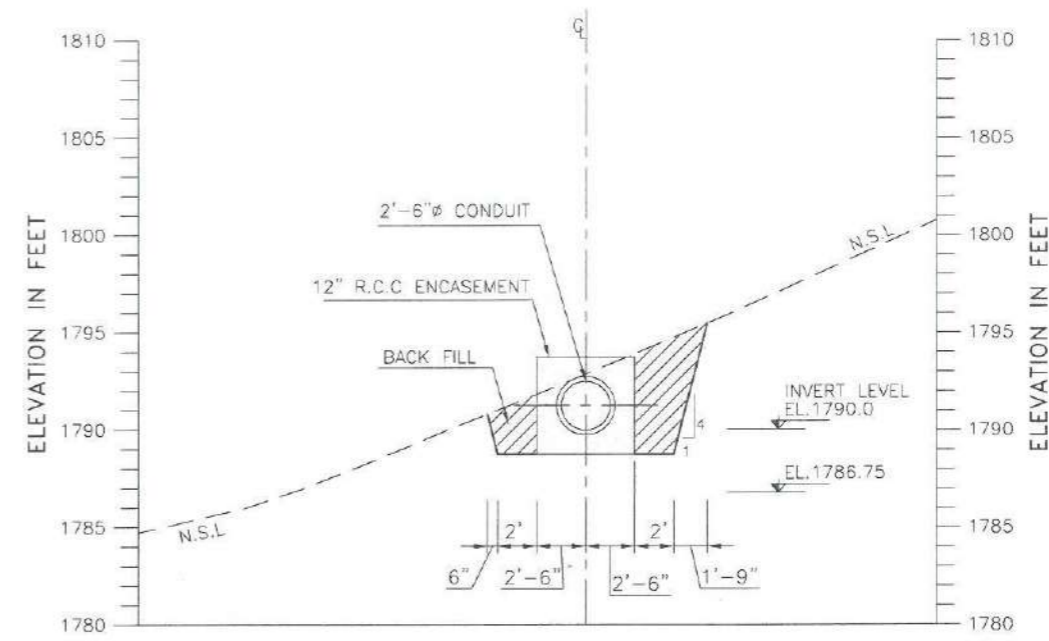

SECTION C-C

REFERENCE DRAWINGS

1. FOR CONDUIT LAYOUT PLAN SEE DWG. NO. 7.1
2. FOR SECTIONS SEE DWG. NO. 7.2 & 7.4
3. FOR DETAILS SEE DWG. NO. 7.5 TO 7.8

NOTE

1. ALL DIMENSIONS AND LEVELS ARE IN FEET.

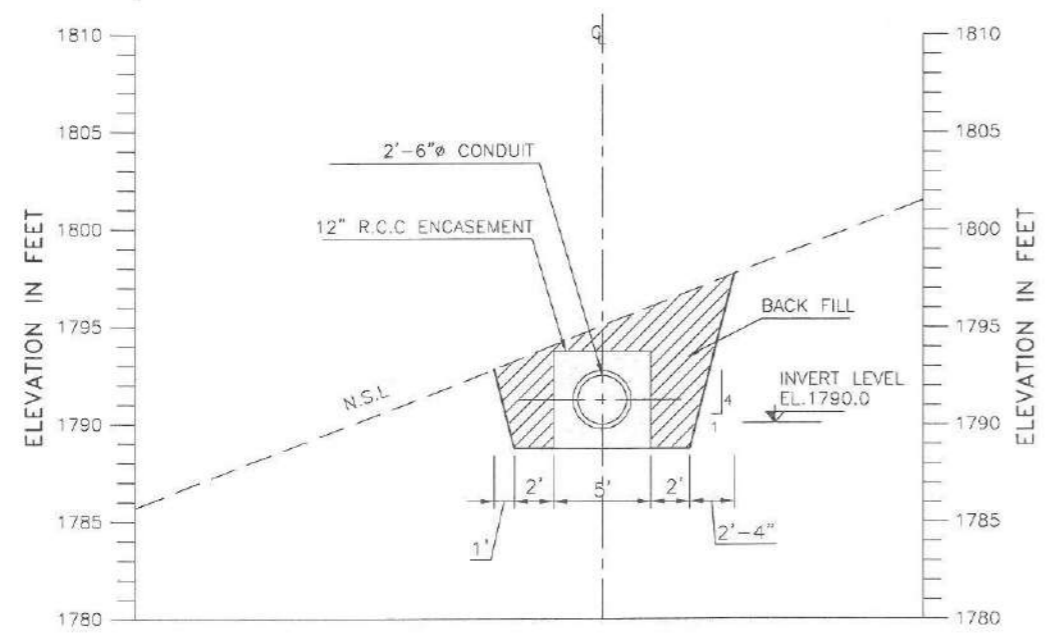

SECTION D-D

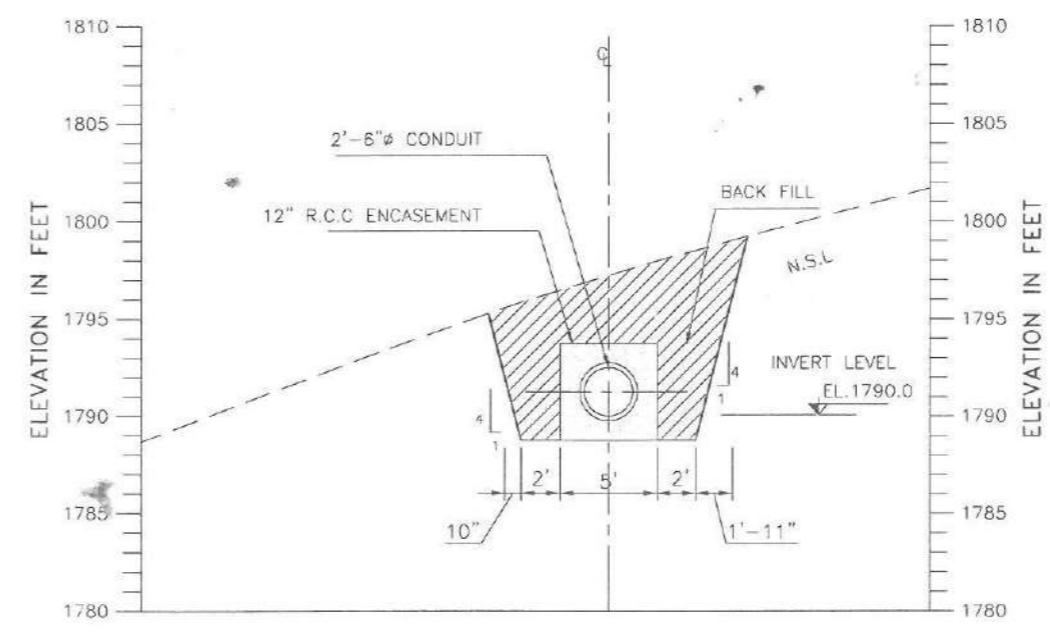

SECTION E-E



S.NO.	DATE	DESCRIPTIONS	CHECK
SMALL DAMS ORGANIZATION, IRRIGATION DEPARTMENT			
SMALL DAM PROJECT			
SUMARI PAYAN DAM CONDUIT CROSS SECTIONS			
PAKISTAN ENGINEERING SERVICES (PVT.) LTD. 16B-Y, COMMERCIAL AREA, PHASE-III, D.H.A. LAHORE.			
DRAWN:	ZAHID RANA	DATE: JUNE 2009	REV. No.
DESIGNED:	ZESHAN	DRAWING NO.	
CHECKED:	D.K. KIRMANI	7.3	
APPROVED:	S/PT. UL. HASSAN NAQVI		

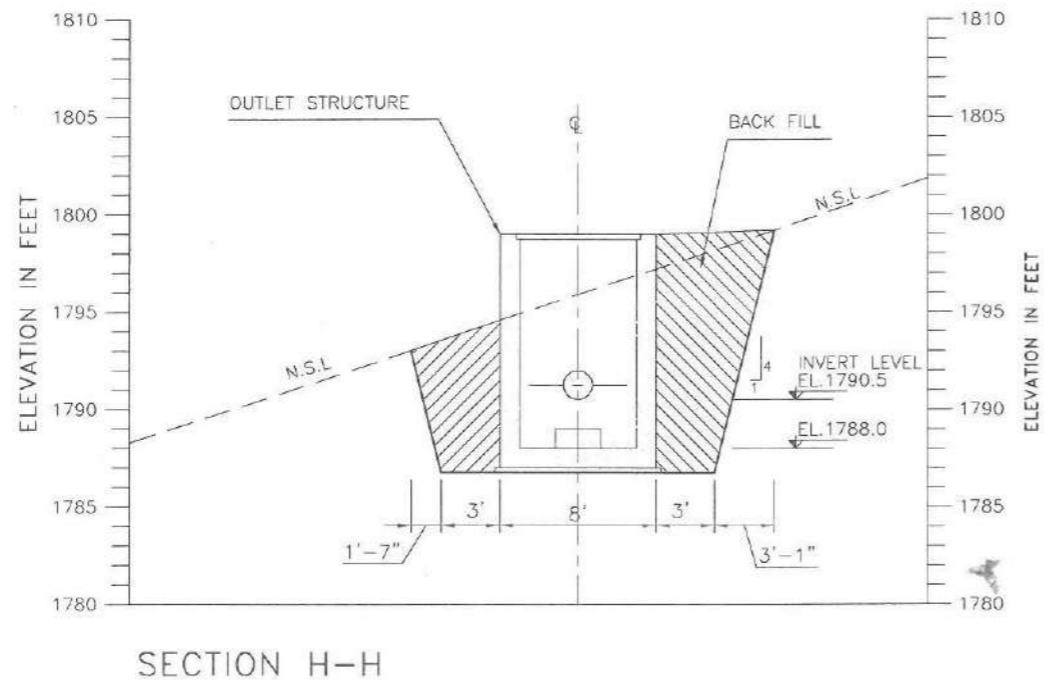
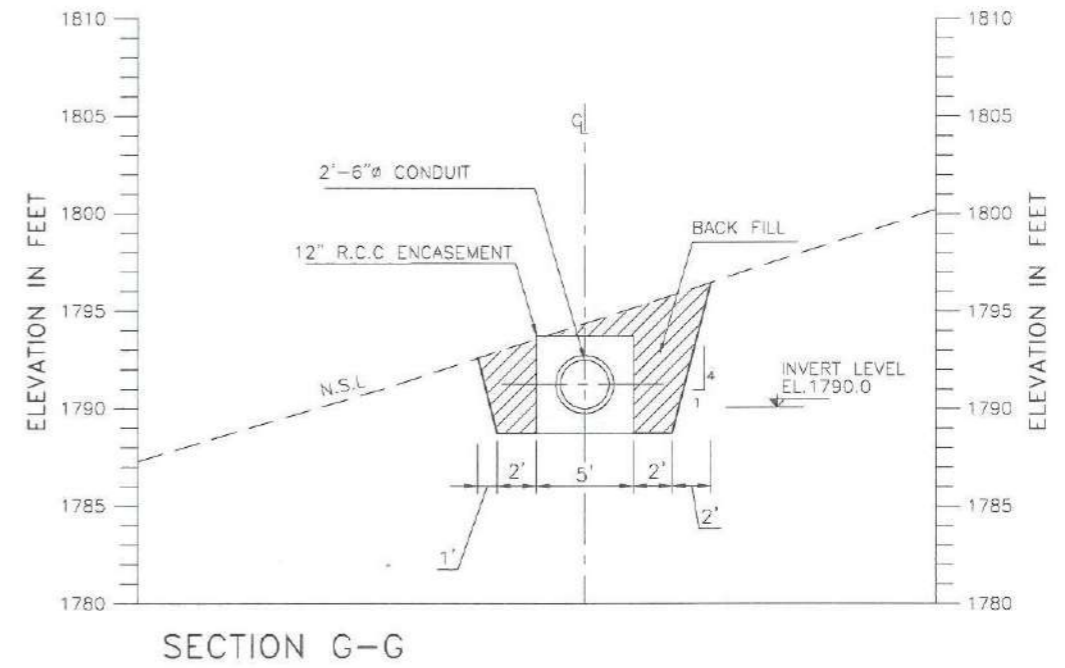
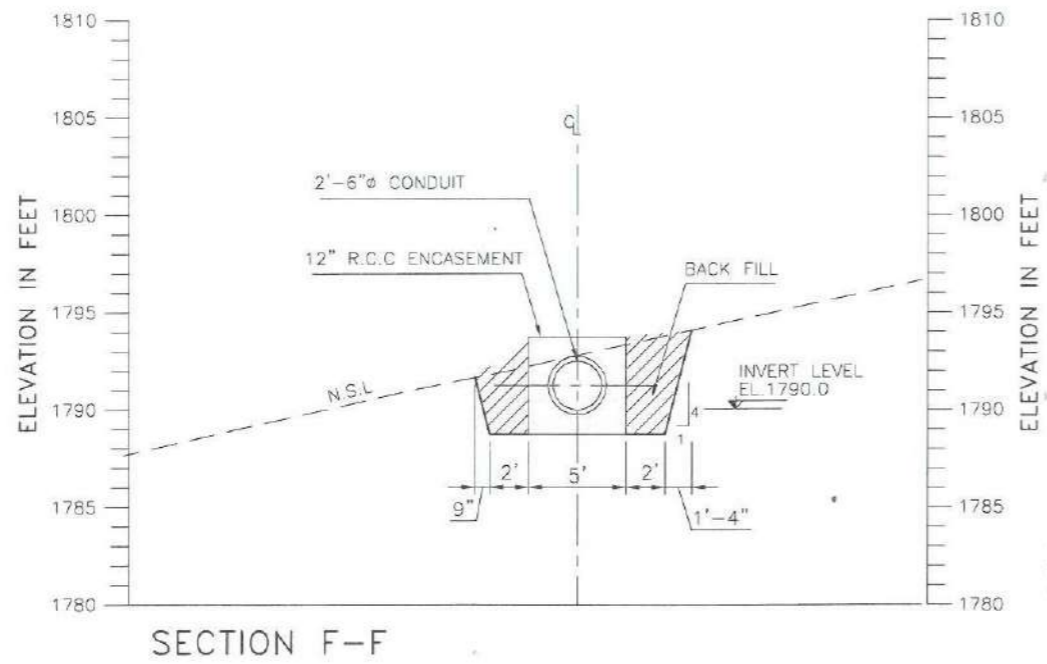

REFERENCE DRAWINGS

1. FOR CONDUIT LAYOUT PLAN SEE DWG. NO. 7.1
2. FOR SECTION SEE DWG. NO. 7.2 & 7.3
3. FOR DETAILS SEE DWG. NO. 7.5 TO 7.8

NOTE

1. ALL DIMENSIONS AND LEVELS ARE IN FEET.



S.NO.	DATE	DESCRIPTIONS	CHECK
SMALL DAMS ORGANIZATION, IRRIGATION DEPARTMENT			
SMALL DAM PROJECT			
SUMARI PAYAN DAM CONDUIT CROSS SECTIONS			
 PAKISTAN ENGINEERING SERVICES (PVT.) LTD. 188 -Y, COMMERCIAL AREA, PHASE-III, D.H.S. LAHORE.			
DRAWN:	ZAHID RANA	DATE: JUNE 2009	REV. No.
DESIGNED:	ZESHAN	DRAWING NO.	
CHECKED:	D.K. KIRMANI	7.4	
APPROVED:	SIBT UL HASSAN NAQVI		

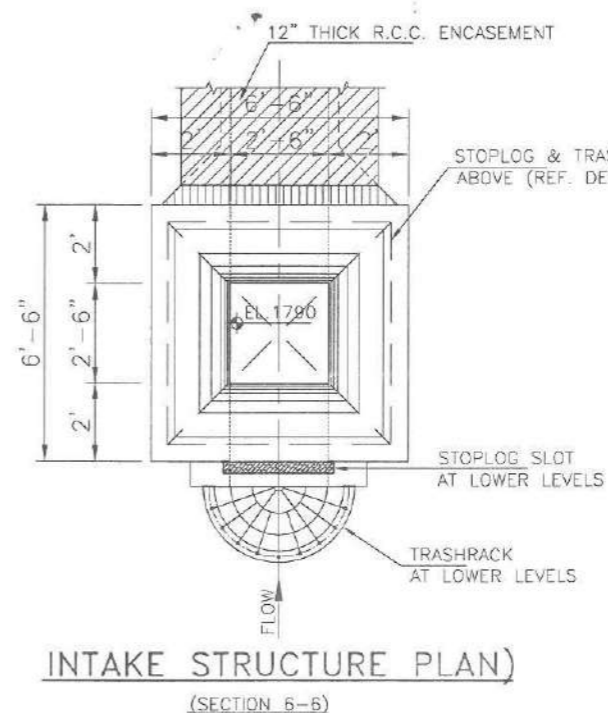
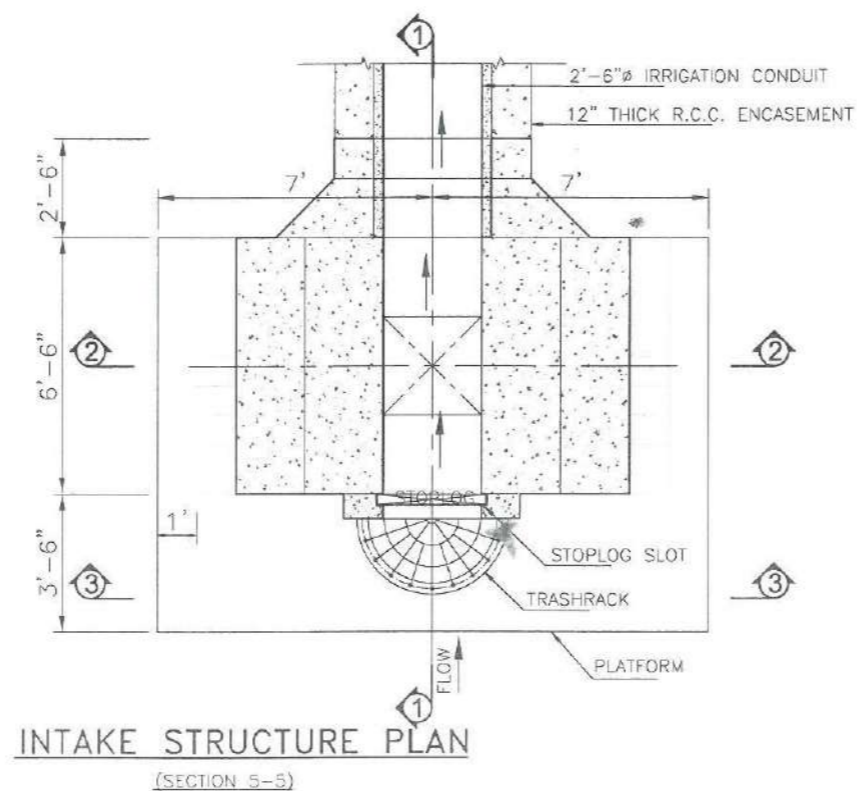
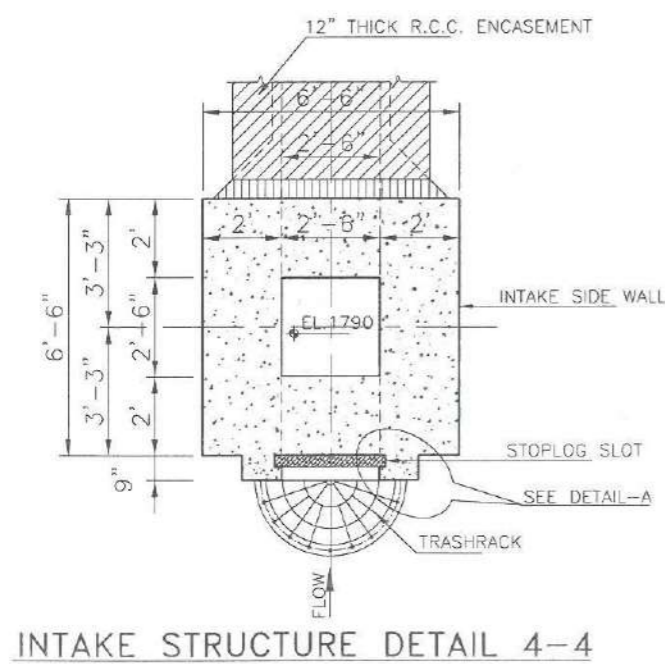
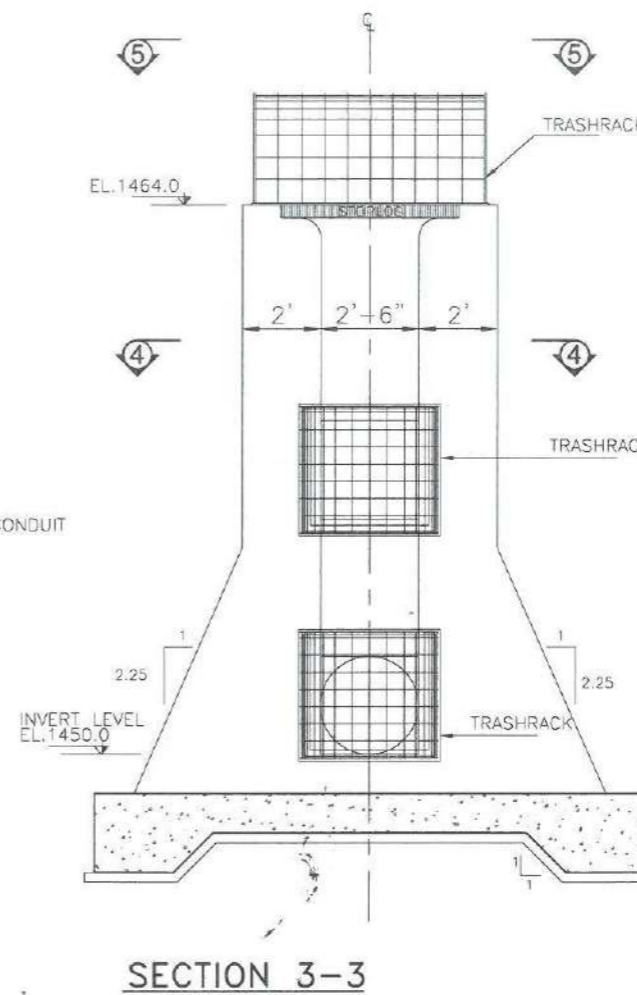
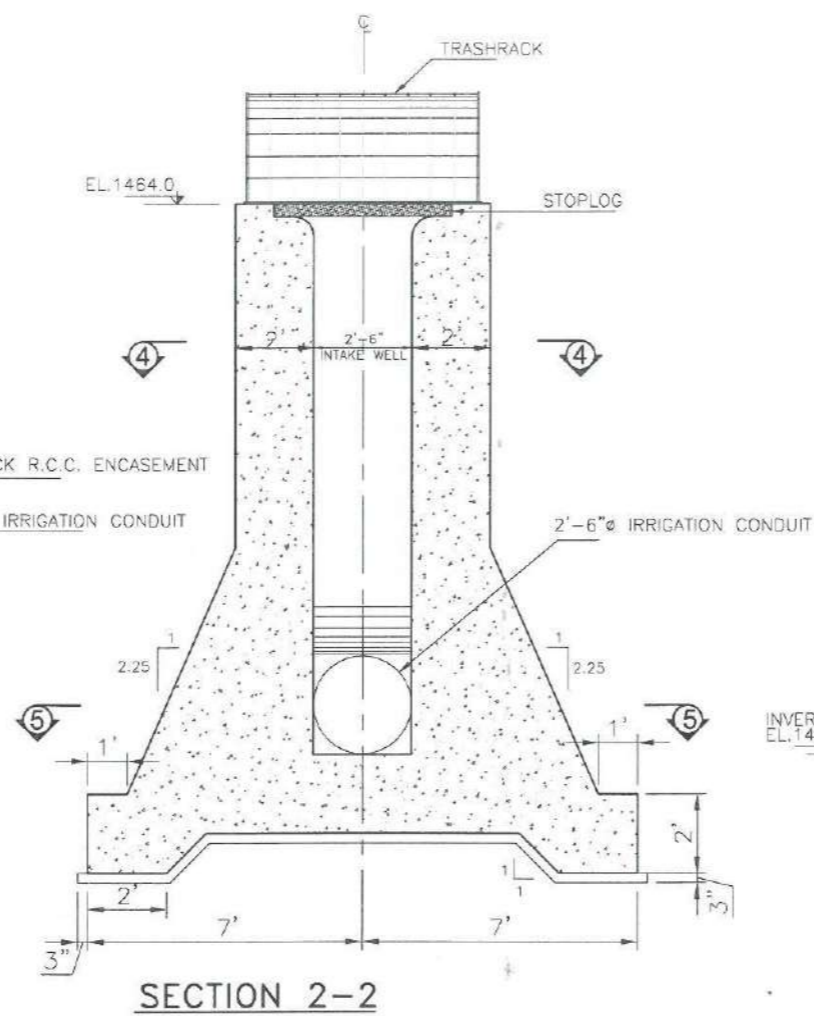
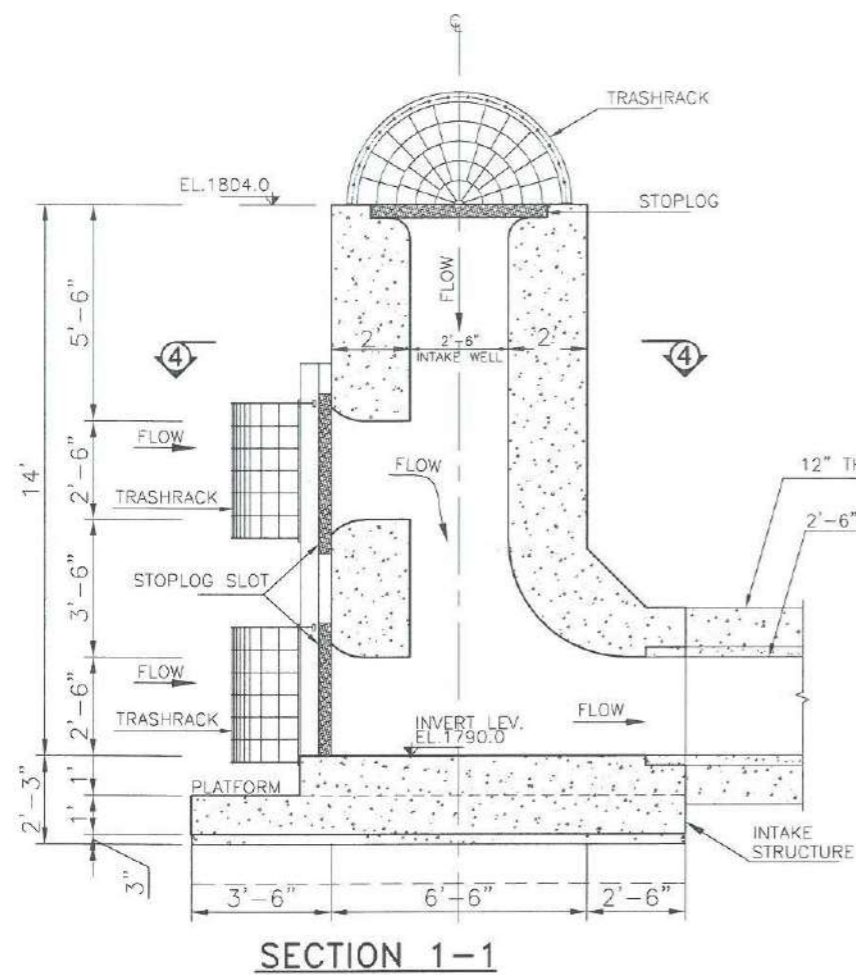

REFERENCE DRAWINGS

1. FOR CONDUIT LAYOUT PLAN SEE DWG. NO. 7.1
2. FOR SECTIONS SEE DWG. NO. 7.2 TO 7.4

NOTE

1. ALL DIMENSIONS AND LEVELS ARE IN FEET.

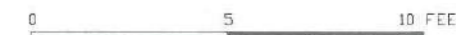

S.NO.	DATE	DESCRIPTIONS	CHECK
SMALL DAMS ORGANIZATION, IRRIGATION DEPARTMENT			
SMALL DAM PROJECT			
SUMARI PAYAN DAM INTAKE STRUCTURE PLAN, SECTIONS AND DETAILS			
PAKISTAN ENGINEERING SERVICES (PVT.) LTD. 188 - Y, COMMERCIAL AREA, PHASE-II, D.H.A, LAHORE.			
DRAWN:	ZAHID RANA	DATE: JUNE 2009	REV. No.
DESIGNED:	ZESHAN	FIGURE NO.	
CHECKED:	D.K. KIRMANI	7.5	
APPROVED:	SIBT UL HASSAN NAQVI		

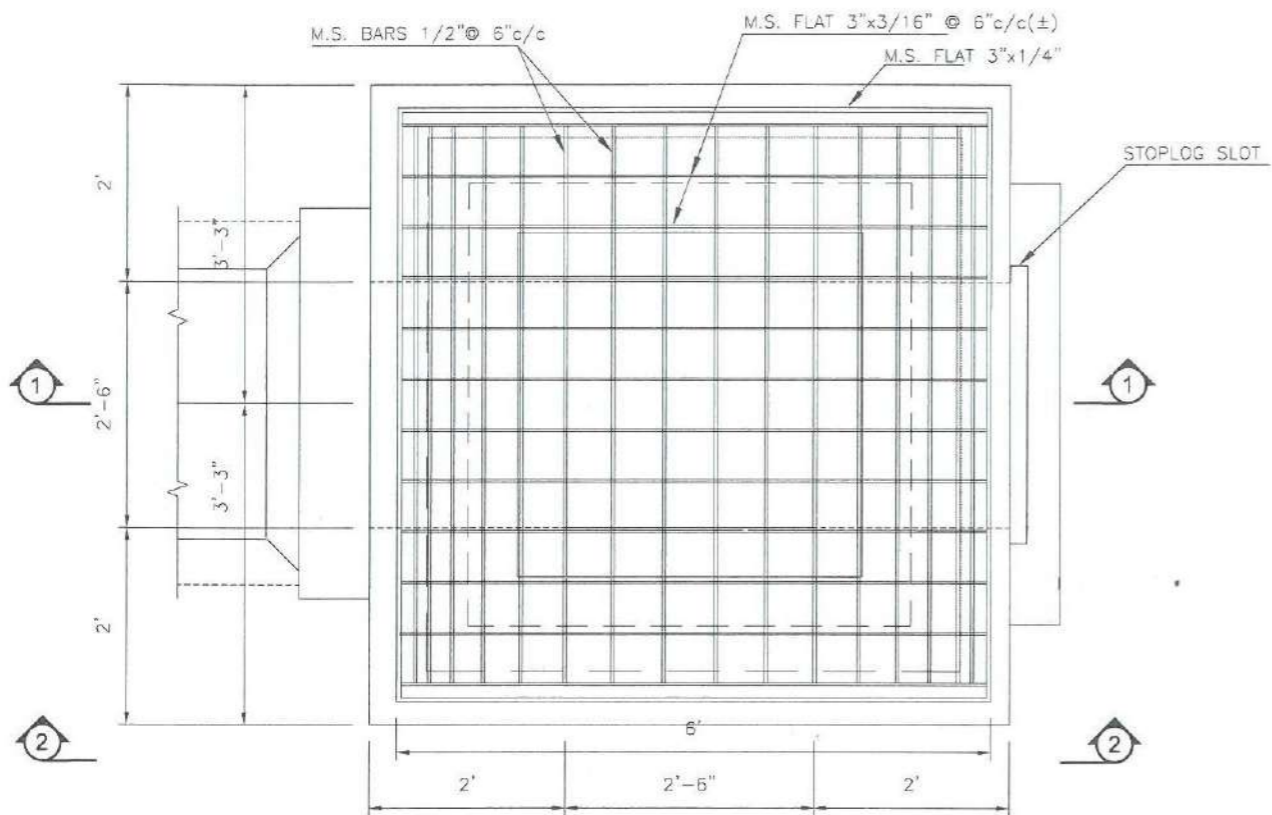

TRASHRACK PLAN
INLET STRUCTURE AT EL.3000.0

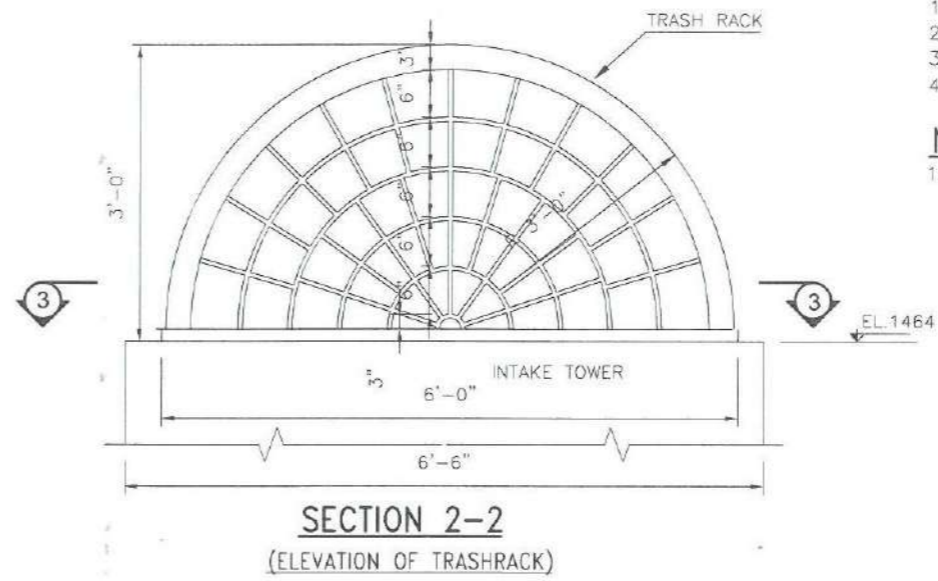

SECTION 2-2
(ELEVATION OF TRASHRACK)

REFERENCE DRAWINGS

1. FOR CONDUIT PLAN SEE DWG. NO. 7.1
2. FOR L-SECTION SEE DWG. NO. 7.2
3. FOR X-SECTIONS SEE DWG. NO. 7.3 & 7.4
4. FOR INTAKE DETAILS SEE DWG. NO. 7.5

NOTE

1. ALL DIMENSIONS AND LEVELS ARE IN FEET.

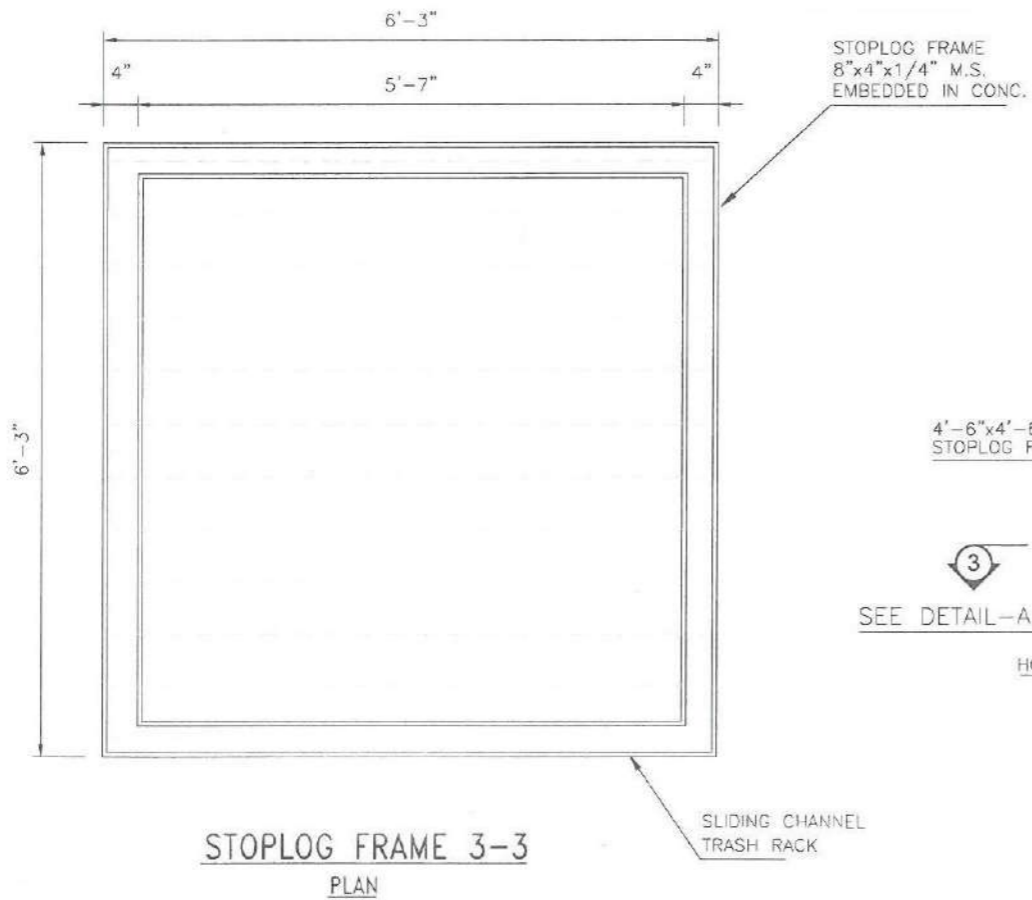
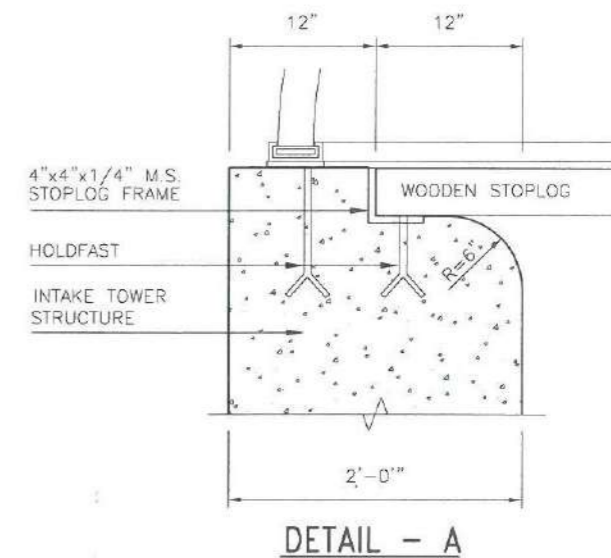

STOPLOG FRAME 3-3
PLAN

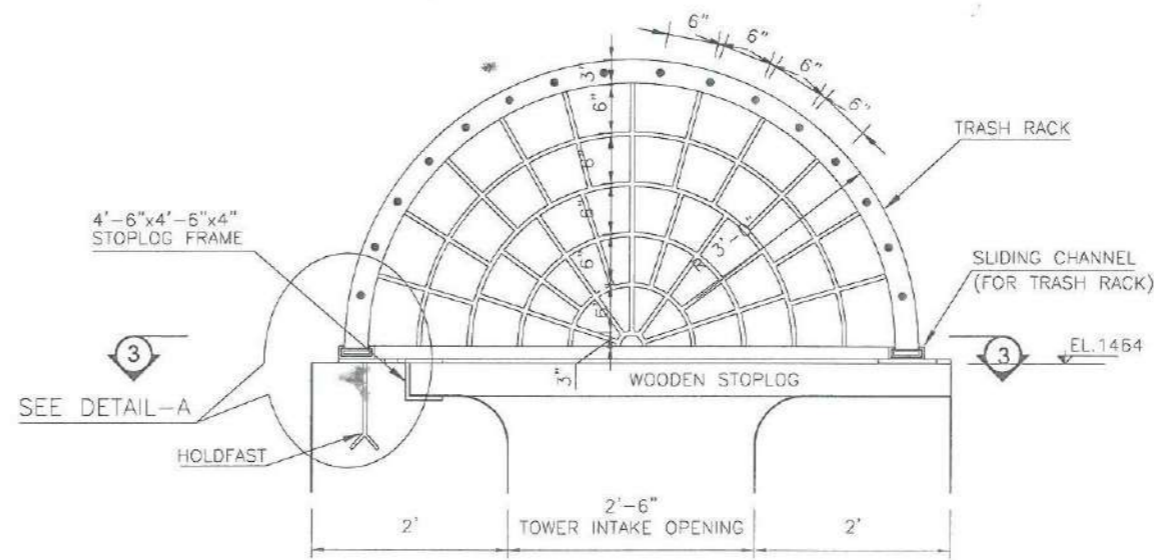

SECTION 1-1

S.NO.	DATE	DESCRIPTIONS	CHECK
SMALL DAMS ORGANIZATION, IRRIGATION DEPARTMENT			
SMALL DAM PROJECT			
SUMARI PAYAN DAM IRRIGATION CONDUIT INTAKE TRASHRACK DETAILS			
 PAKISTAN ENGINEERING SERVICES (PVT.) LTD. <small>188 - Y. COMMERCIAL AREA, PHASE - III, D.H.A., LAHORE.</small>			
DRAWN:	ZAHID RANA	DATE: JUNE 2009	REV. No.
DESIGNED:	ZESHAN	FIGURE NO.	
CHECKED:	D.K. KIRMANI	7.6	
APPROVED:	SIBT UL HASSAN NADVI		

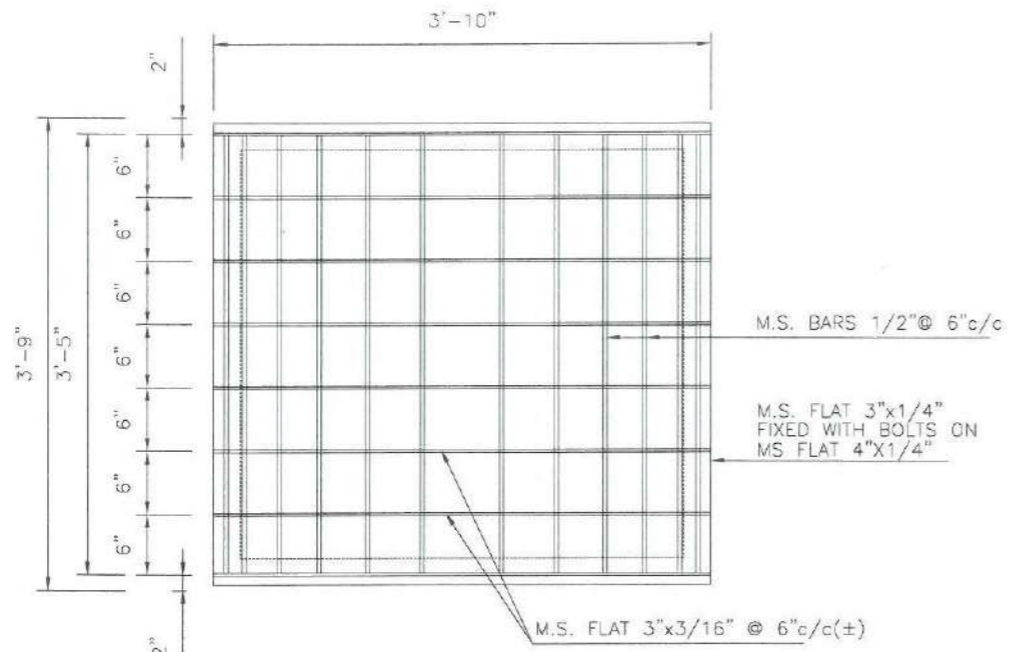

SECTION A-A
LOWER TASHRACK ELEVATION

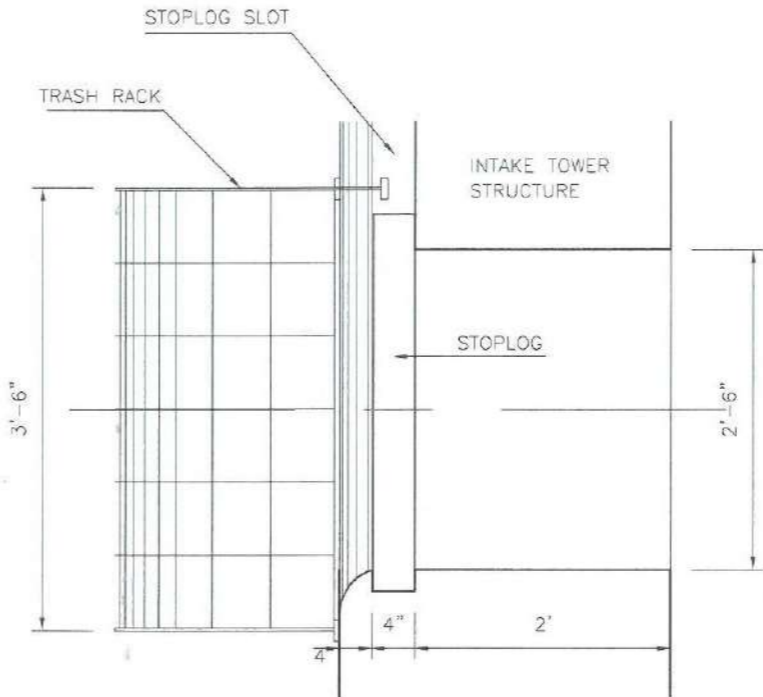

SECTION B-B

REFERENCE DRAWINGS

1. FOR CONDUIT PLAN SEE DWG. NO. 7.1
2. FOR L-SECTION SEE DWG. NO. 7.2
3. FOR X-SECTIONS SEE DWG. NO. 7.3 & 7.4
4. FOR INTAKE DETAILS SEE DWG. NO. 7.5

NOTE

1. ALL DIMENSIONS AND LEVELS ARE IN FEET.

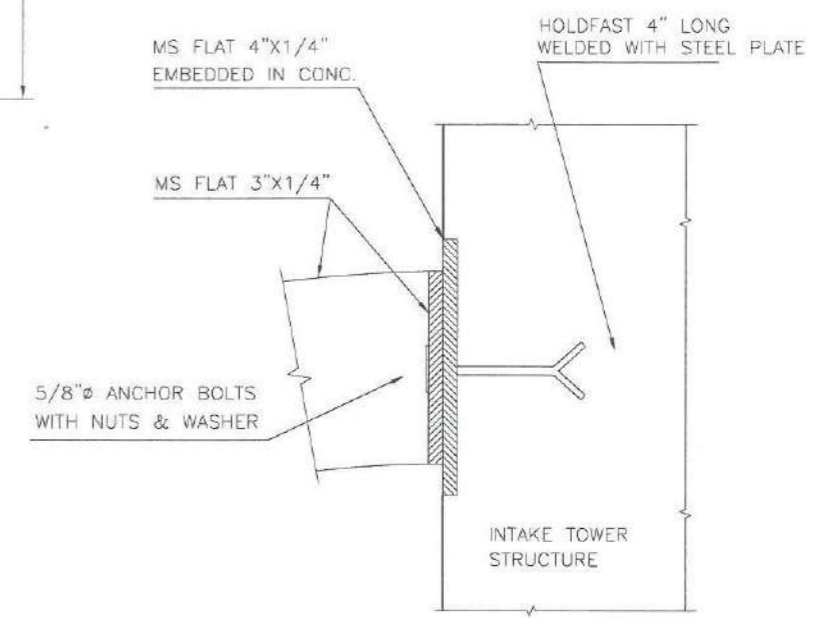

DETAIL - 1

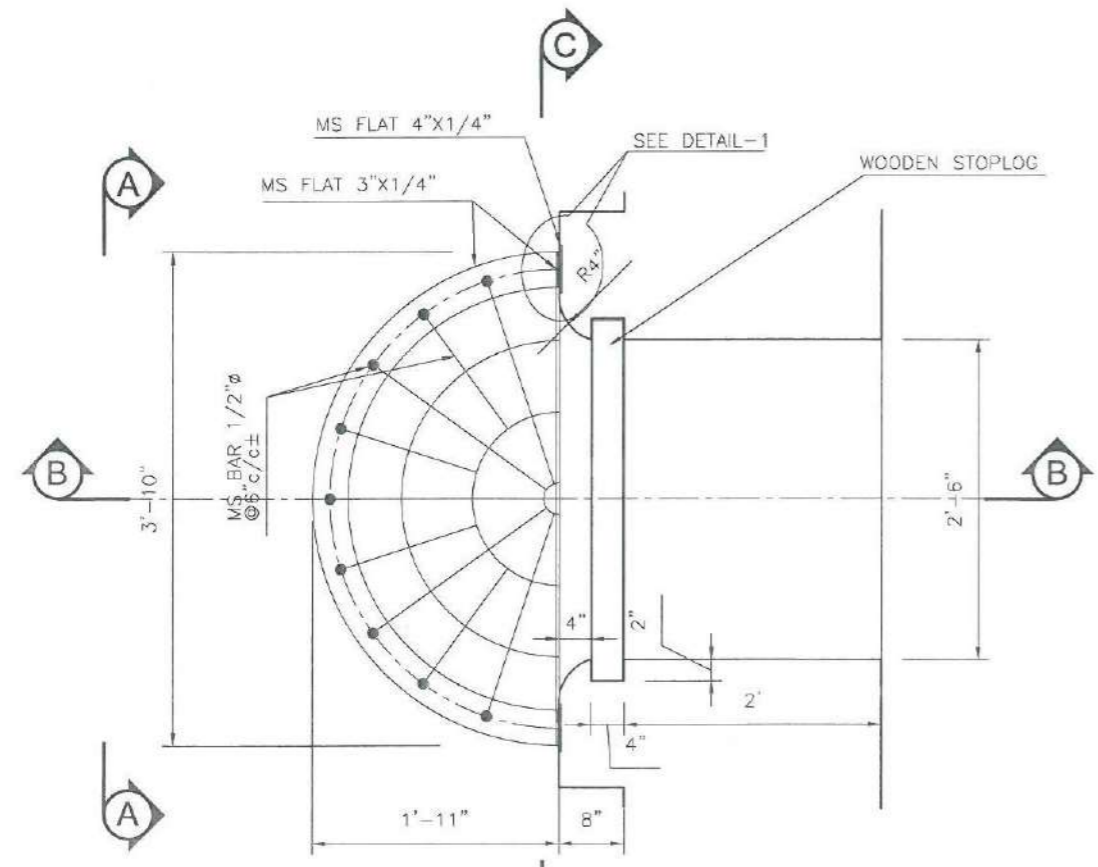

LOWER TASHRACK
PLAN

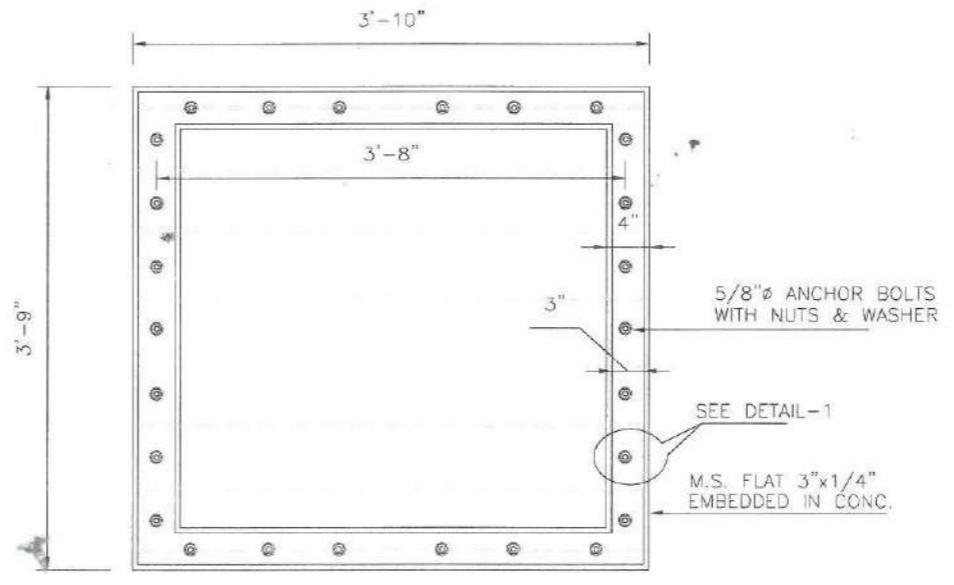

SECTION C-C
LOWER TASHRACK FRAME

S.NO.	DATE	DESCRIPTIONS	CHECK
SMALL DAMS ORGANIZATION, IRRIGATION DEPARTMENT			
SMALL DAM PROJECT			
SUMARI PAYAN DAM TRASHRACK AND STOPLOG DETAILS INTAKE OPENING AT LOWER LEVEL			
PAKISTAN ENGINEERING SERVICES (PVT.) LTD. 18B - Y, COMMERCIAL AREA, PHASE-III, D.H.A. LAHORE.			
DRAWN:	ZAHID RANA	DATE: JUNE 2009	REV. No.
DESIGNED:	ZESHAN	FIGURE NO.	
CHECKED:	D.K. KIRMANI	7.7	
APPROVED:	S/BT UL HASSAN NAQVI		

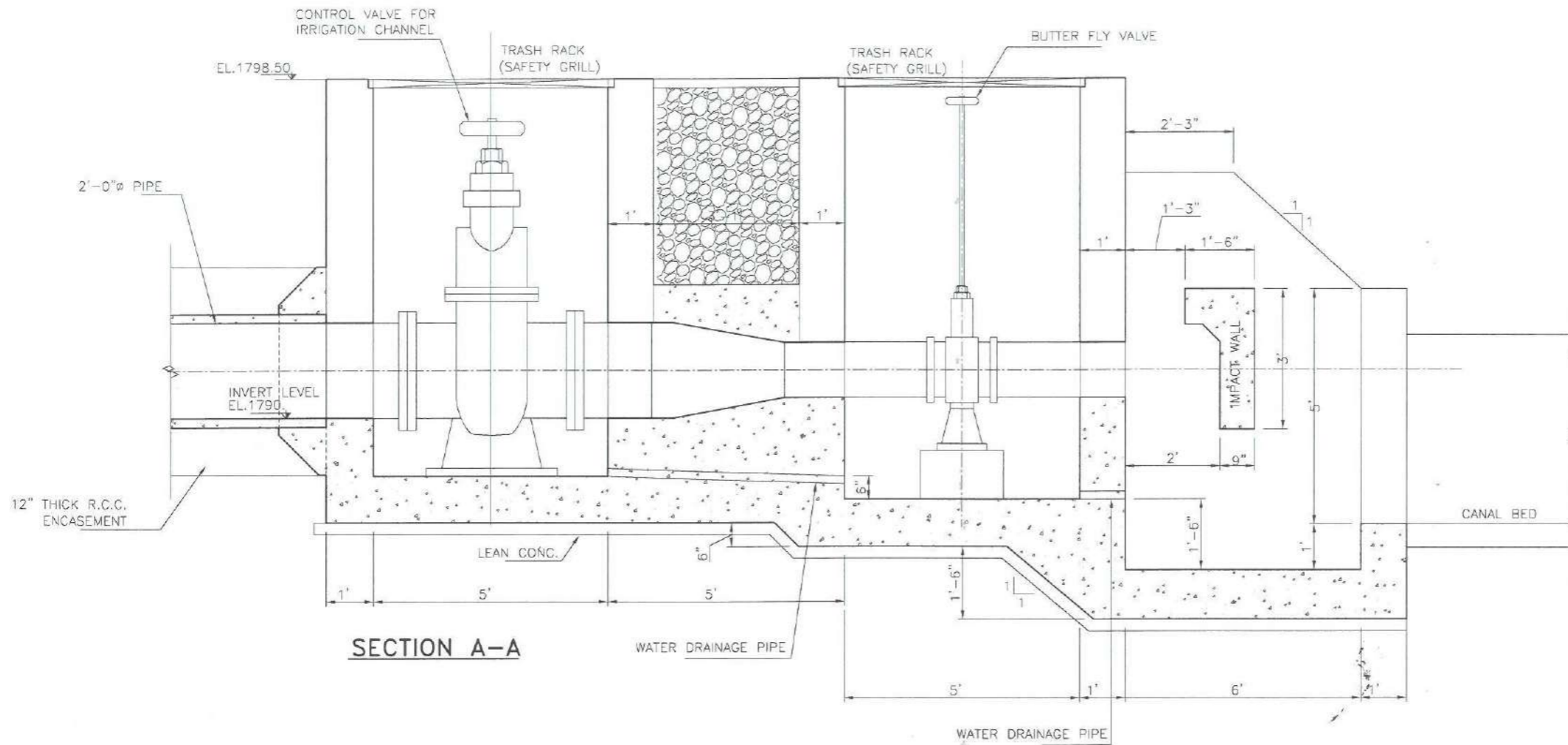

SECTION A-A

REFERENCE DRAWINGS

1. FOR CONDUIT PLAN SEE DWG. NO. 7.1
2. FOR L-SECTION SEE DWG. NO. 7.2
3. FOR X-SECTIONS SEE DWG. NO. 7.3 & 7.4

NOTE

1. ALL DIMENSIONS AND LEVELS ARE IN FEET.

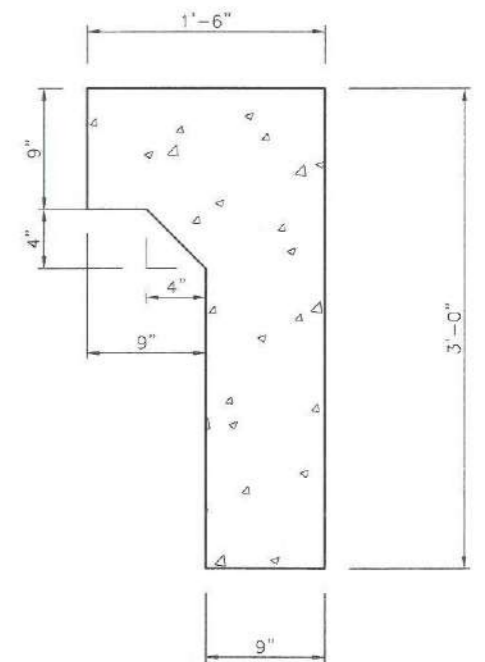

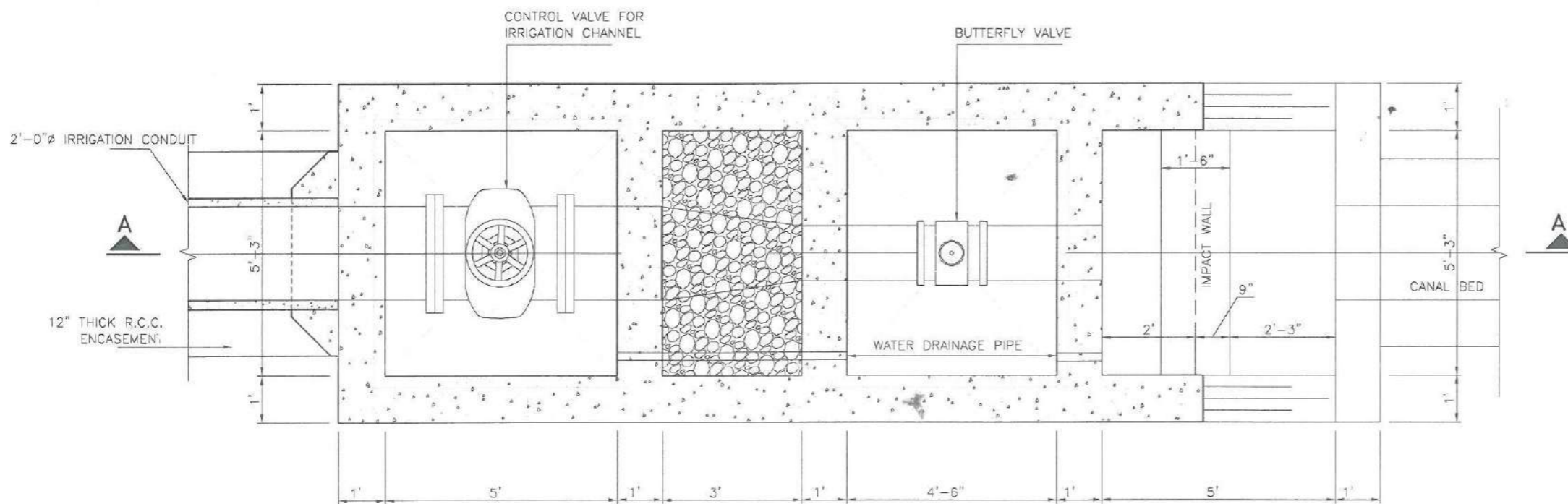

IMPACT WALL DETAIL

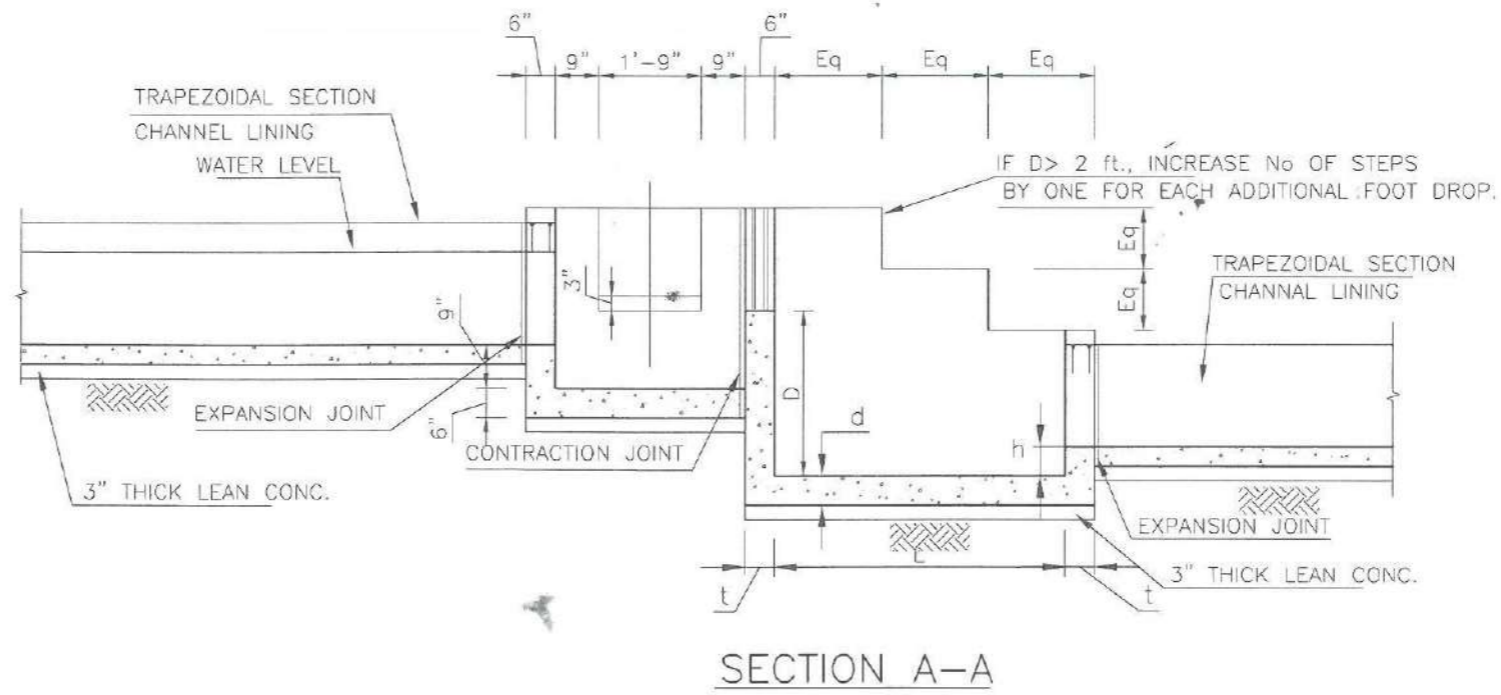
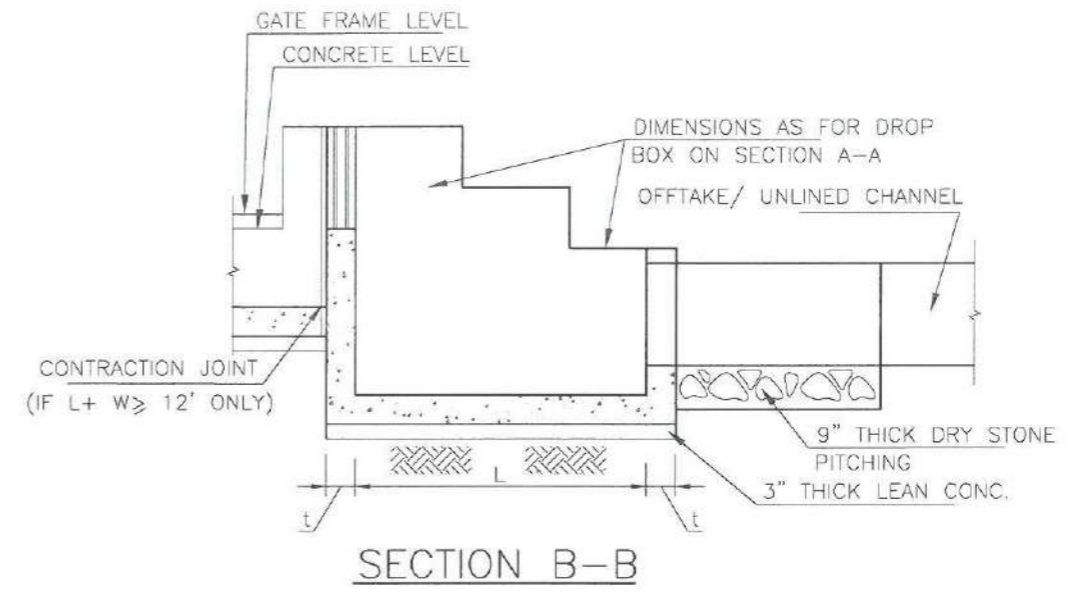
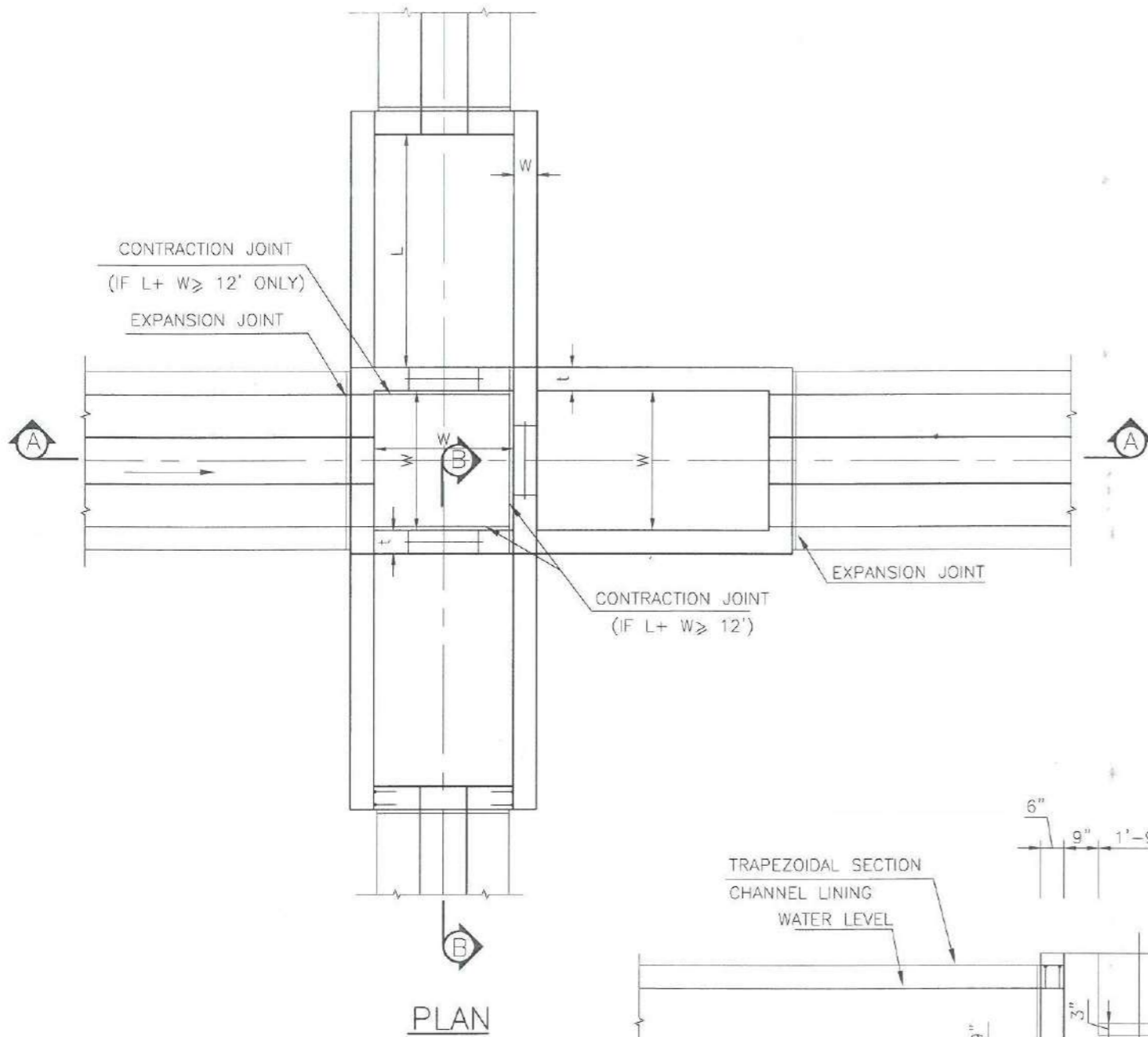

OUTLET STRUCTURE PLAN

S.NO.	DATE	DESCRIPTIONS	CHECK
SMALL DAMS ORGANIZATION, IRRIGATION DEPARTMENT			
SMALL DAM PROJECT			
SUMARI PAYAN DAM IRRIGATION CONDUIT OUTLET STRUCTURE & DETAILS			
PAKISTAN ENGINEERING SERVICES (PVT.) LTD. 18B - Y, COMMERCIAL AREA, PHASE-III, D.H.A, LAHORE			
DRAWN:	ZAHID RANA	DATE: JUNE 2009	REV. No.
DESIGNED:	ZESHAN	FIGURE NO.	
CHECKED:	D.K. KIRMANI	7.B	
APPROVED:	SIBT UL HASSAN NAQVI		



S.NO.	DATE	DESCRIPTIONS	CHECK
SMALL DAMS ORGANIZATION IRRIGATION DEPARTMENT			
SMALL DAM PROJECT			
OUTLET (TYPICAL)			
 PAKISTAN ENGINEERING SERVICES (PVT.) LTD. 188 -Y, COMMERCIAL AREA, PHASE-II, D.H.A. LAHORE.			
DRAWN:	M.NAEEM MINHAS	DATE: JUNE 2009	REV. No.
DESIGN:	ANWAR KHAN	DRAWING NO.	
CHECKED:	D.K. KIRAZANI	7.13	
APPROVED:	SIBT UL HASSAN NAQVI		

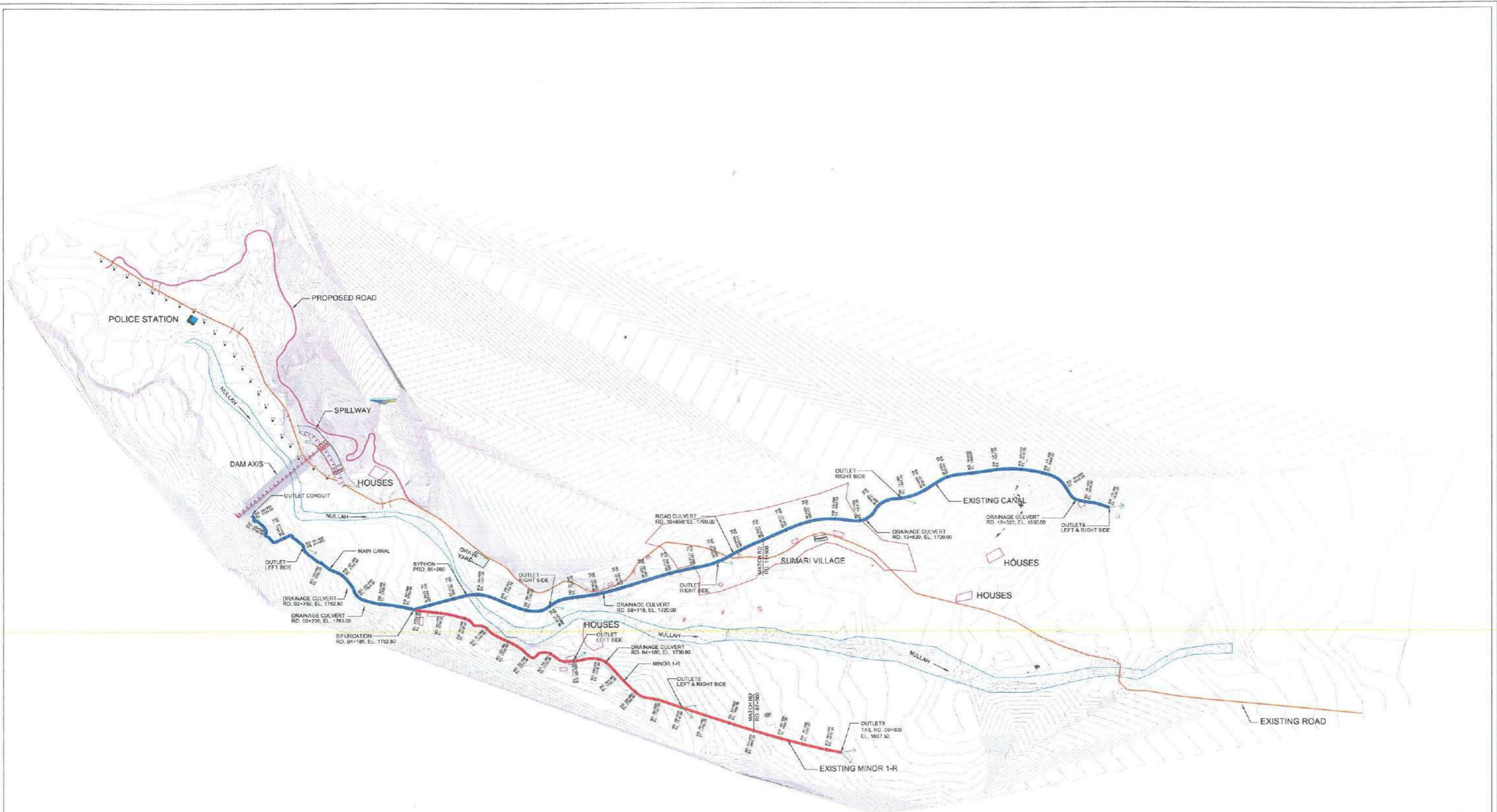

S.NO.	DATE	DESCRIPTIONS	CHECK
SMALL DAMS ORGANIZATION, IRRIGATION AND POWER DEPARTMENT			
SMALL DAM PROJECT			
SUMARI PAYAN DAM SURVEY PLAN			
 PAKISTAN ENGINEERING SERVICES (PVT.) LTD. 166 - Y, COMMERCIAL AREA, PHASE-III, D.H.A. LAHORE.			
DRAWN:	MOHSIN	DATE: JUNE, 2009	REV. No.
DESIGNED:	ZELSHAN	FIGURE NO.	
CHECKED:	I.K. KIRMANI	SPD-S-2.1	
APPROVED:	SIBTUL HASSAN		



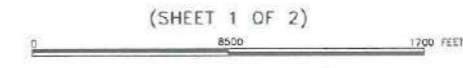
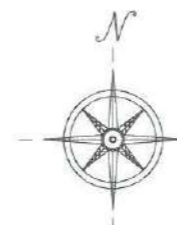
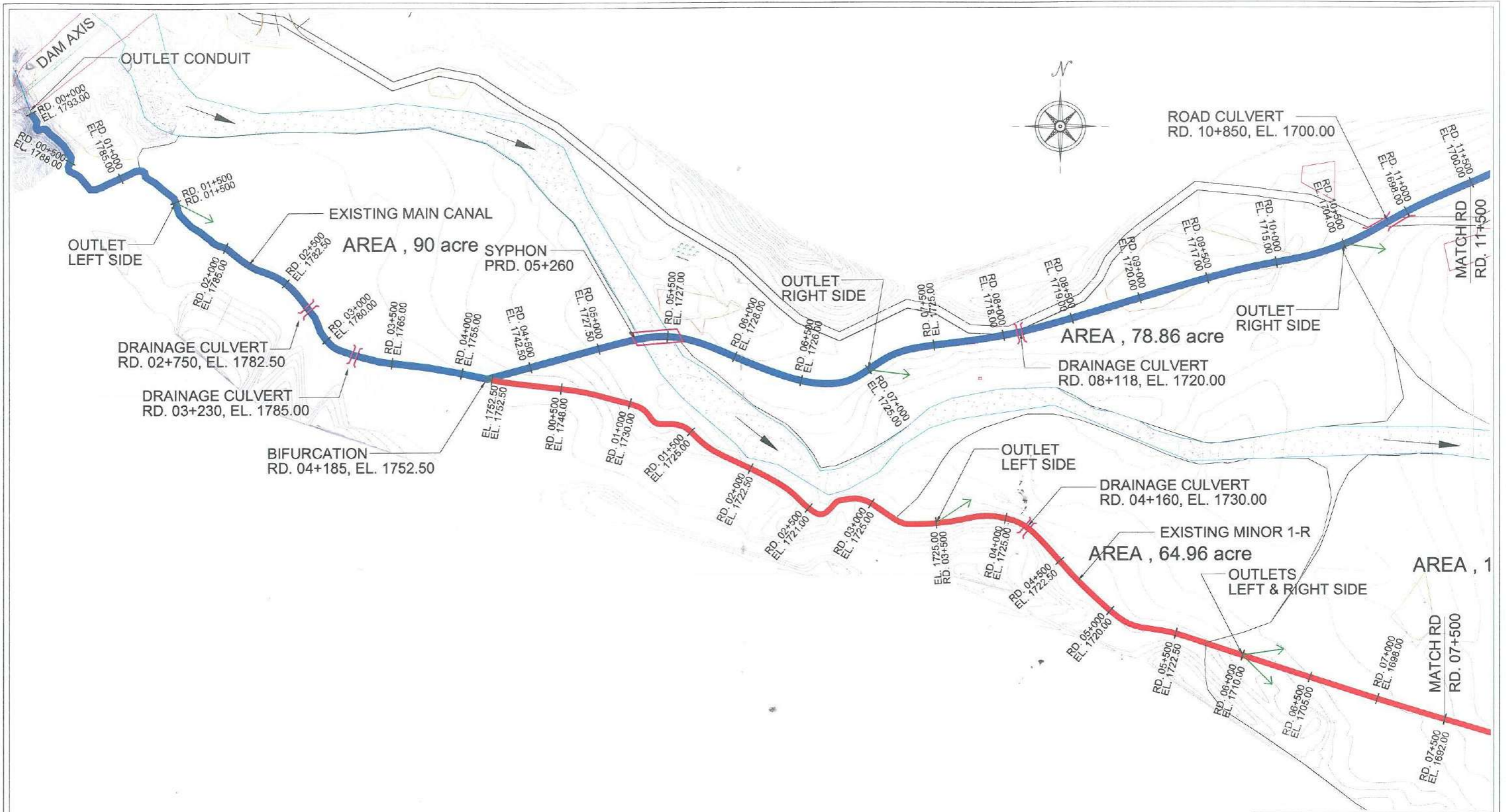

S. NO.	DATE	DESCRIPTIONS	CHECK
SMALL DAMS ORGANIZATION, IRRIGATION AND POWER DEPARTMENT			
SMALL DAM PROJECT			
SUMARI PAYAN DAM CANAL LAYOUT PLAN			
PAKISTAN ENGINEERING SERVICES (PVT.) LTD. 18B - F, COMMERCIAL AREA, PHASE - III, D.H.A. LAHORE.			
DRAWN:	MIDHISIN	DATE: JUNE, 2008	REV. NO.
DESIGNED:	ZEEHSAN	FIGURE NO.	
CHECKED:	D. K. KIRMANI	SPD-IRRI-7.9	
APPROVED:	SIBTUL HASSAN		

(SHEET 1 OF 2)

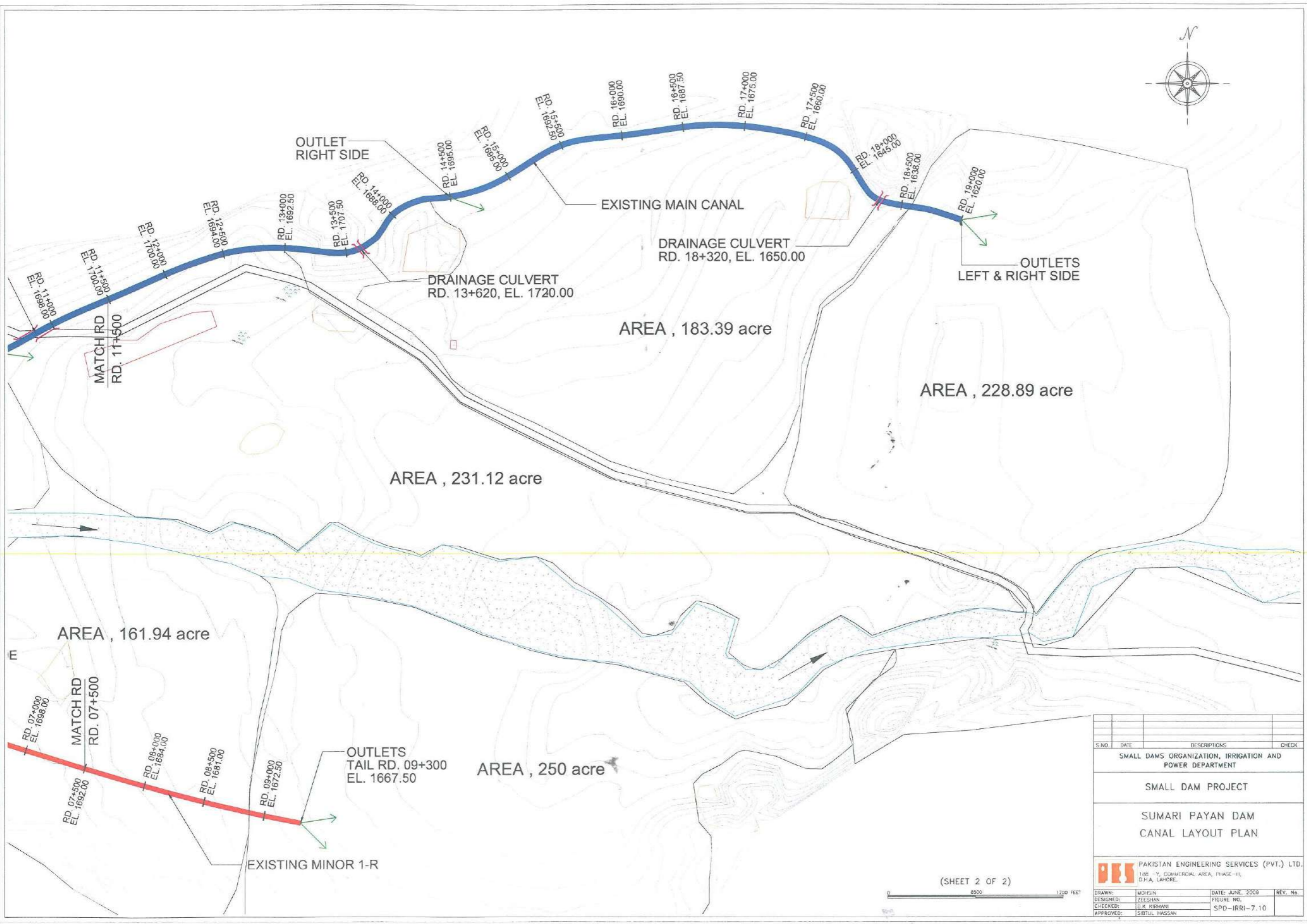
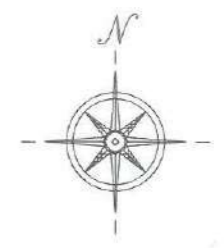

OUTLET
RIGHT SIDE

EXISTING MAIN CANAL

DRAINAGE CULVERT
RD. 18+320, EL. 1650.00

OUTLETS
LEFT & RIGHT SIDE

DRAINAGE CULVERT
RD. 13+620, EL. 1720.00

AREA , 183.39 acre

AREA , 228.89 acre

AREA , 231.12 acre

AREA , 161.94 acre

AREA , 250 acre

OUTLETS
TAIL RD. 09+300
EL. 1667.50

EXISTING MINOR 1-R

MATCH RD
RD. 11+500

MATCH RD
RD. 07+500

(SHEET 2 OF 2)

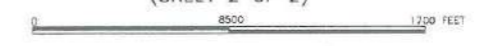

S.NO.	DATE	DESCRIPTIONS	CHECK
SMALL DAMS ORGANIZATION, IRRIGATION AND POWER DEPARTMENT			
SMALL DAM PROJECT			
SUMARI PAYAN DAM CANAL LAYOUT PLAN			
PAKISTAN ENGINEERING SERVICES (PVT.) LTD. 108 - Y, COMMERCIAL AREA, PHASE-III, D.H.A. LAHORE.			
DRAWN:	MUHSIN	DATE:	JUNE, 2009
DESIGNED:	ZEESEHAN	FIGURE NO.	
CHECKED:	D. K. KIRMANI	SPD-IRRI-7.10	
APPROVED:	SIBTUL HASSAN		

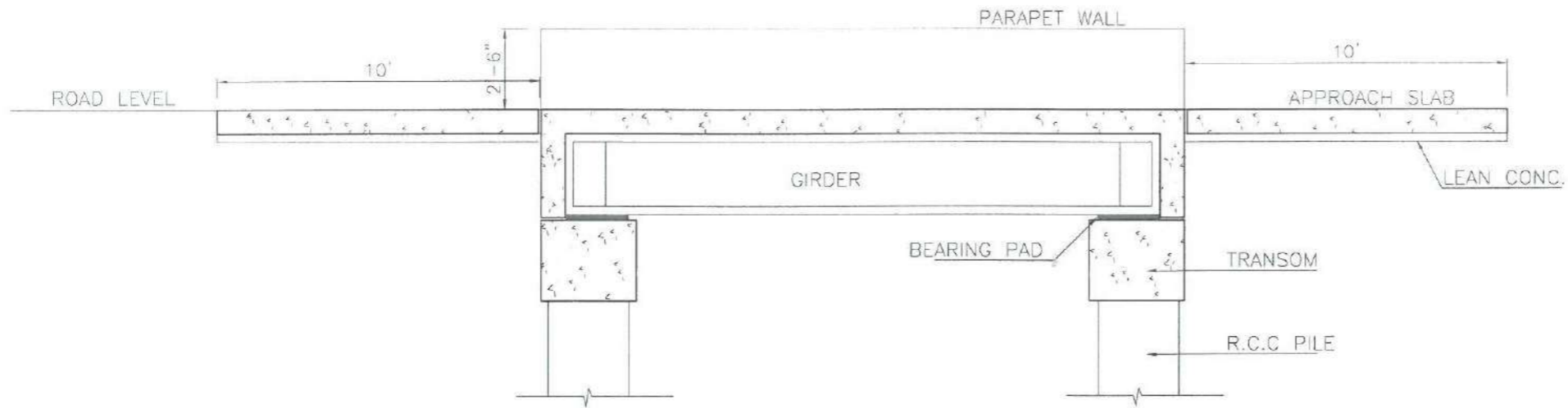

SECTION A-A

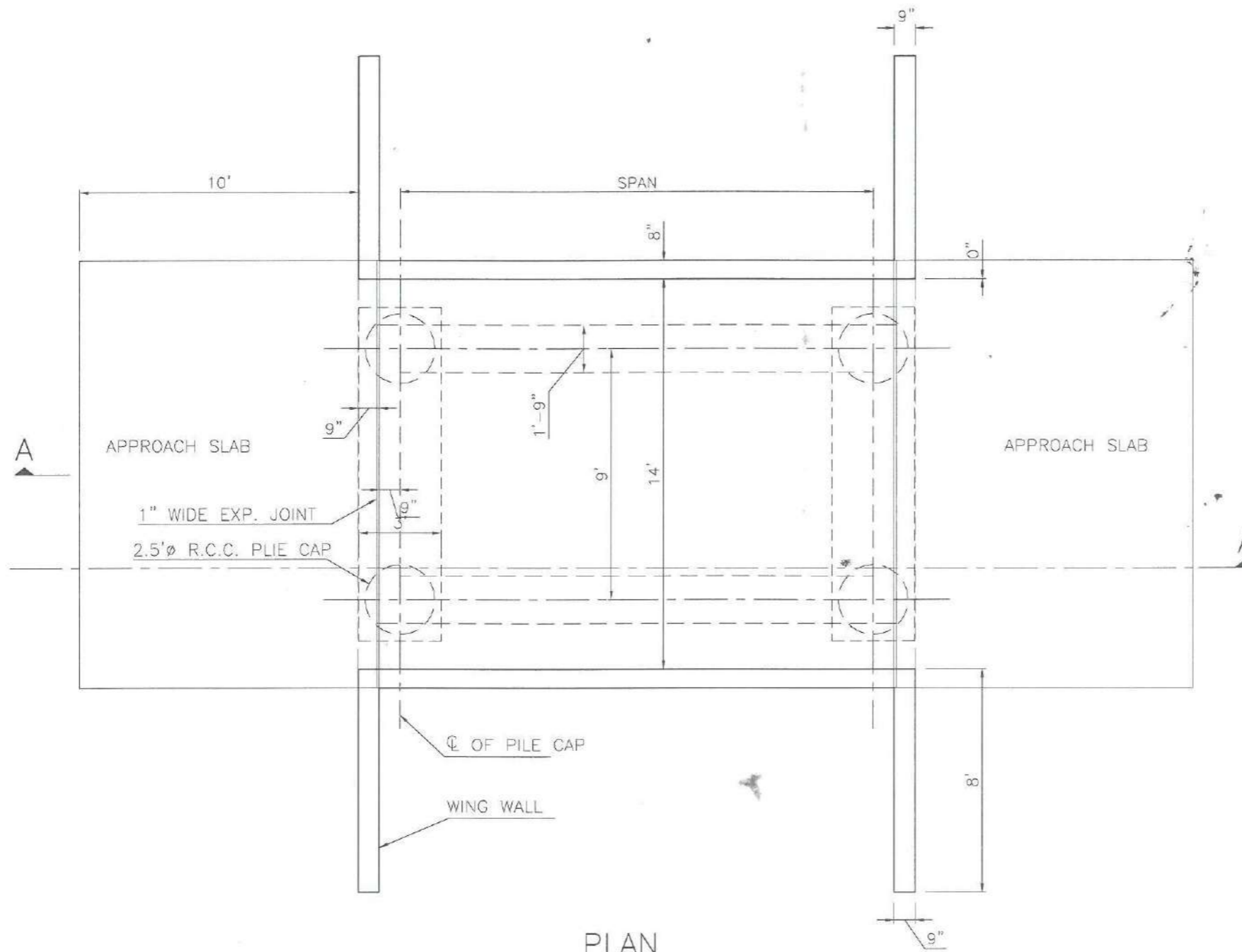

PLAN

S.NO.	DATE	DESCRIPTIONS	CHECK
SMALL DAMS ORGANIZATION IRRIGATION DEPARTMENT			
SMALL DAM PROJECT			
V.R BRIDGE PLAN & SECTION (TYP)			
 PAKISTAN ENGINEERING SERVICES (PVT.) LTD. 188 -Y, COMMERCIAL AREA, PHASE-III, D.H.A. LAHORE.			
DRAWN:	ZAHID RANA	DATE: JUNE 2009	REV. No.
DESIGNED:	ANWAR KHAN	DRAWING NO.	
CHECKED:	D.K. KIRMANI		
APPROVED:	SIBT UL HASSAN NAQVI	7.11	

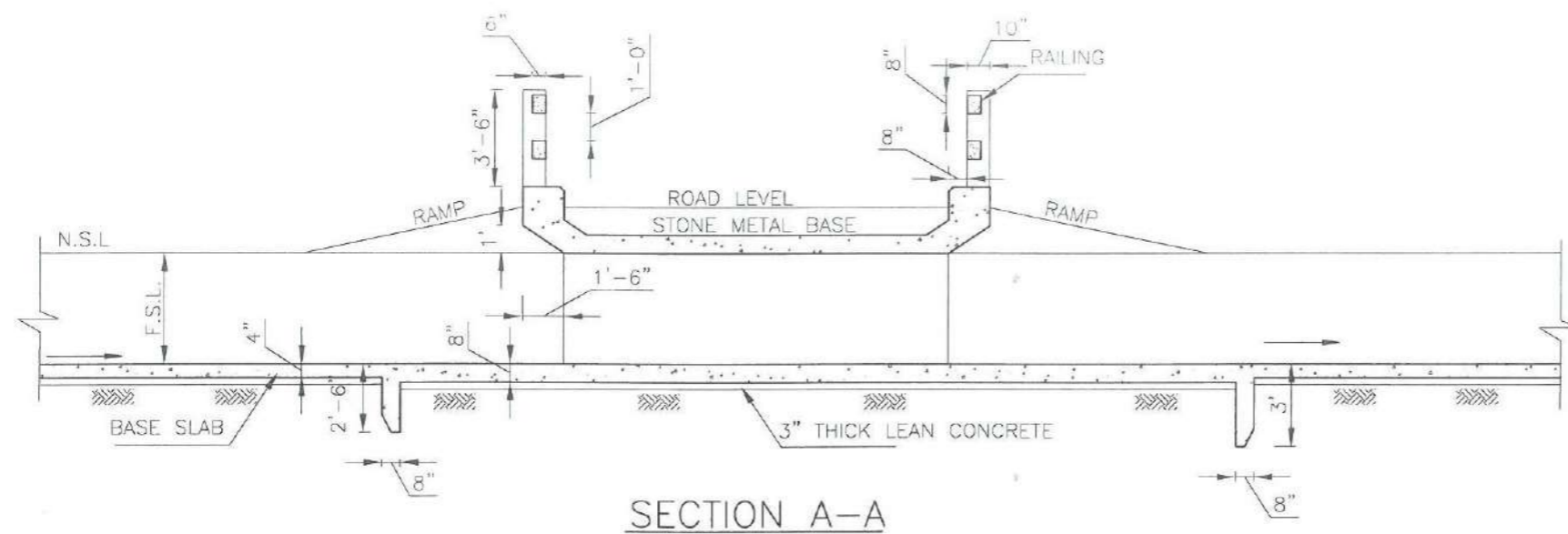

SECTION A-A

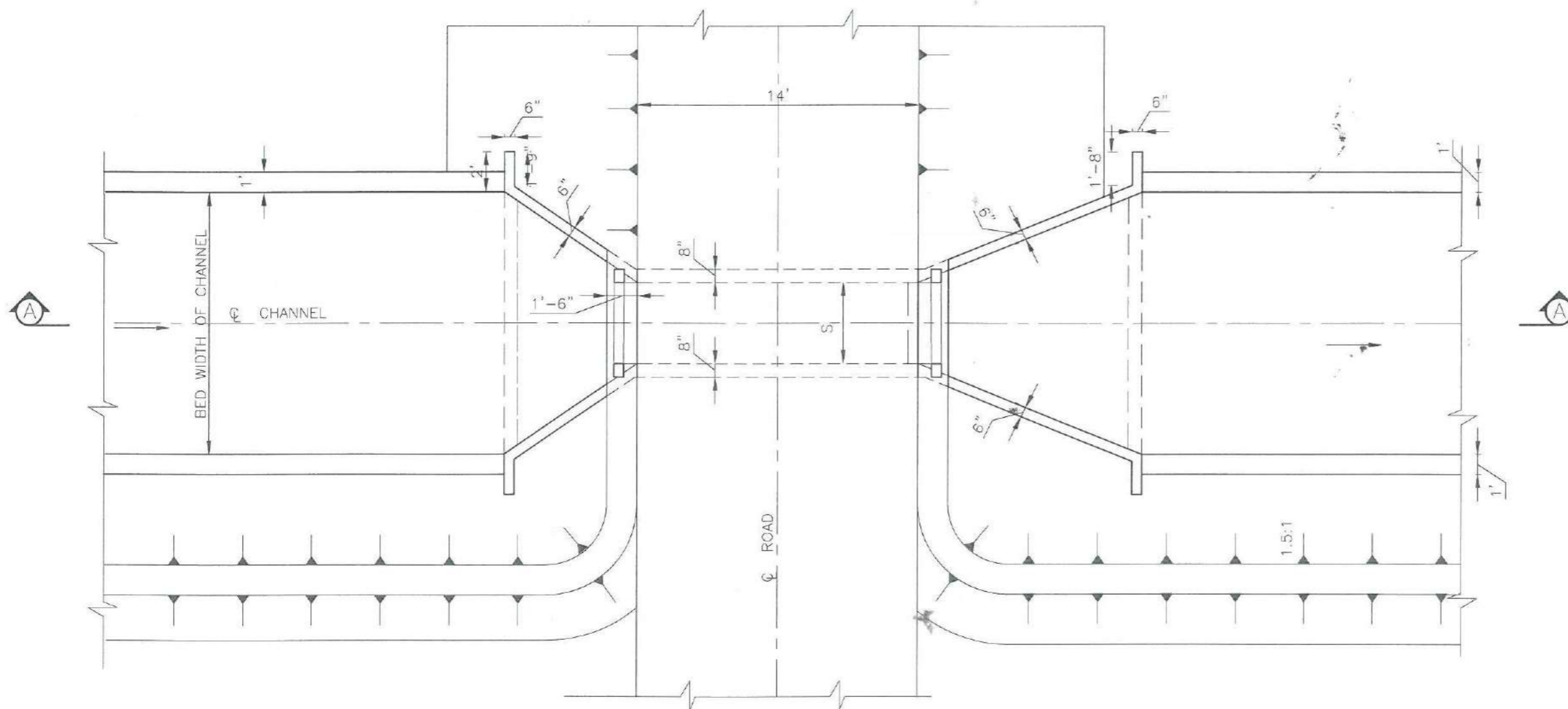

PLAN

S.NO.	DATE	DESCRIPTIONS	CHECK
SMALL DAMS ORGANIZATION IRRIGATION DEPARTMENT			
SMALL DAM PROJECT			
ROAD CULVERT (TYP.)			
 PAKISTAN ENGINEERING SERVICES (PVT.) LTD. 188 -Y, COMMERCIAL AREA, PHASE-III, D.H.A, LAHORE.			
DRAWN:	ZAHID RANA	DATE: JUNE 2009	REV. No.
DESIGNED:	ANWAR KHAN	DRAWING NO.	
CHECKED:	D.K. KIRMANI	7.12	
APPROVED:	SIBT UL HASSAN NAQVI		

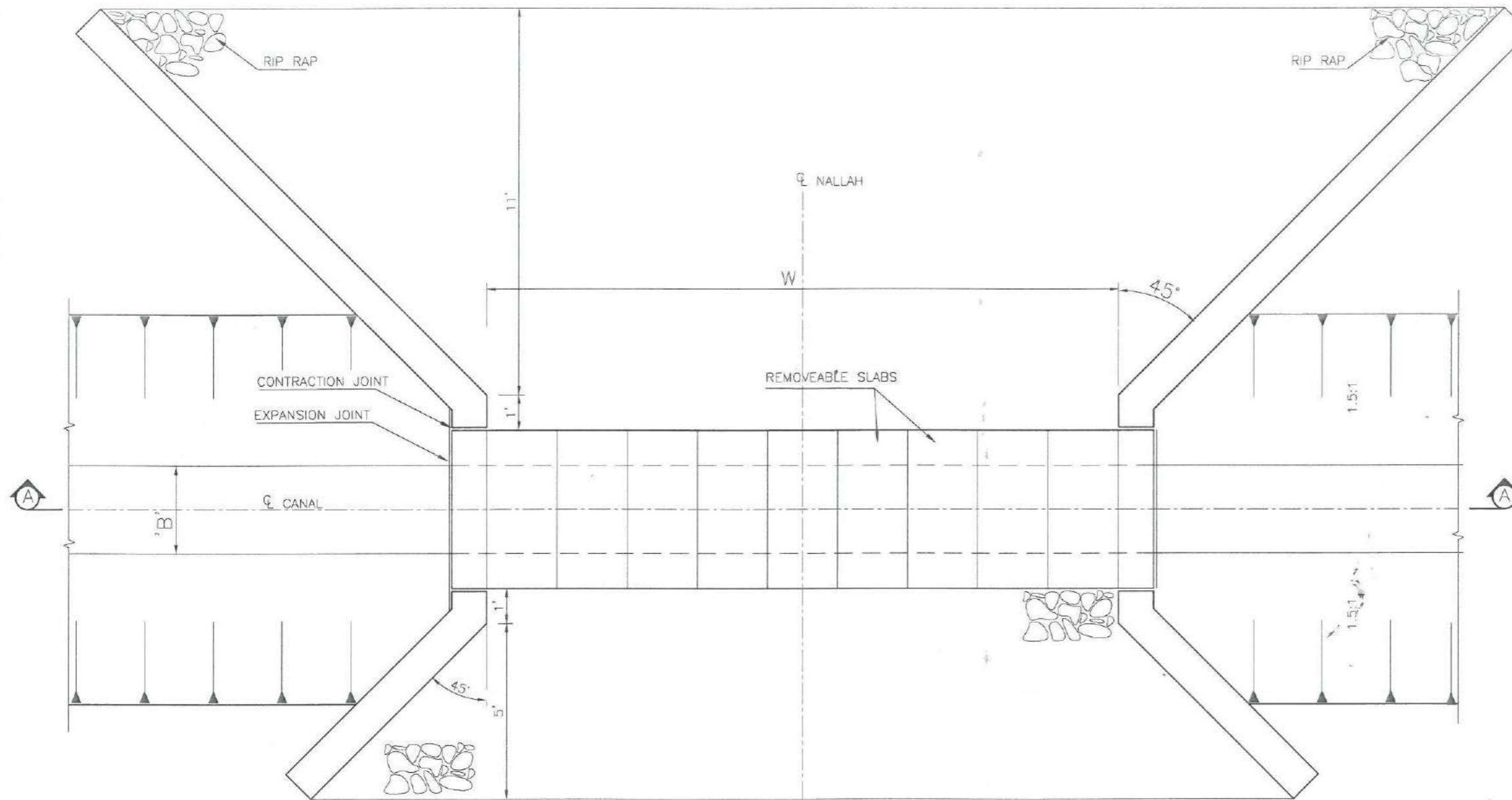

PLAN

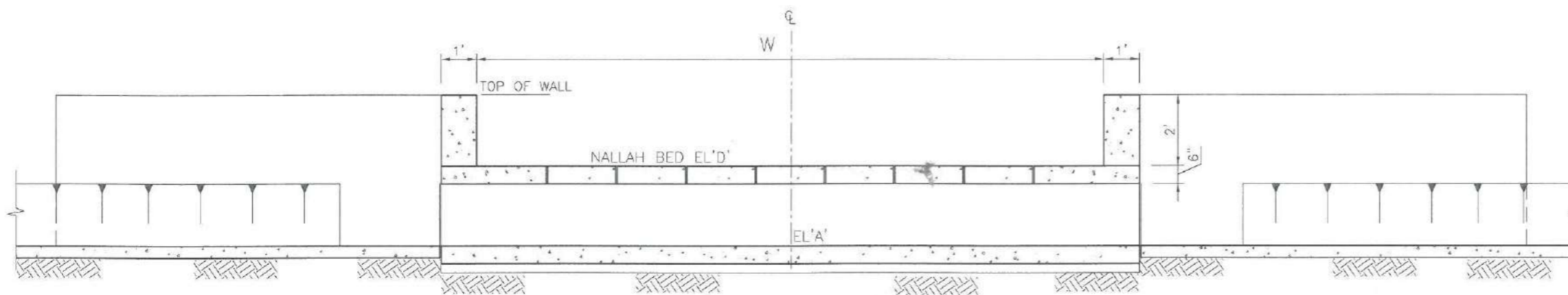

SECTION A-A

S.NO.	DATE	DESCRIPTIONS	CHECK
SMALL DAMS ORGANIZATION IRRIGATION DEPARTMENT			
SMALL DAM PROJECT			
AQUEDUCT PLAN AND SECTION (TYPICAL)			
 PAKISTAN ENGINEERING SERVICES (PVT.) LTD. 188 - Y, COMMERCIAL AREA, PHASE-III, D.H.A, LAHORE.			
DRAWN:	ZAHID RANA	DATE: JUNE 2009	REV. No.
DESIGNED:	ANWAR IQHAN	DRAWING NO.	
CHECKED:	D.K. KORMANI	7.14	
APPROVED:	SIBT UL HASSAN NAQVI		

NOTE:-
1:- ALL LEVEL AND DIMENSIONS ARE IN FEET

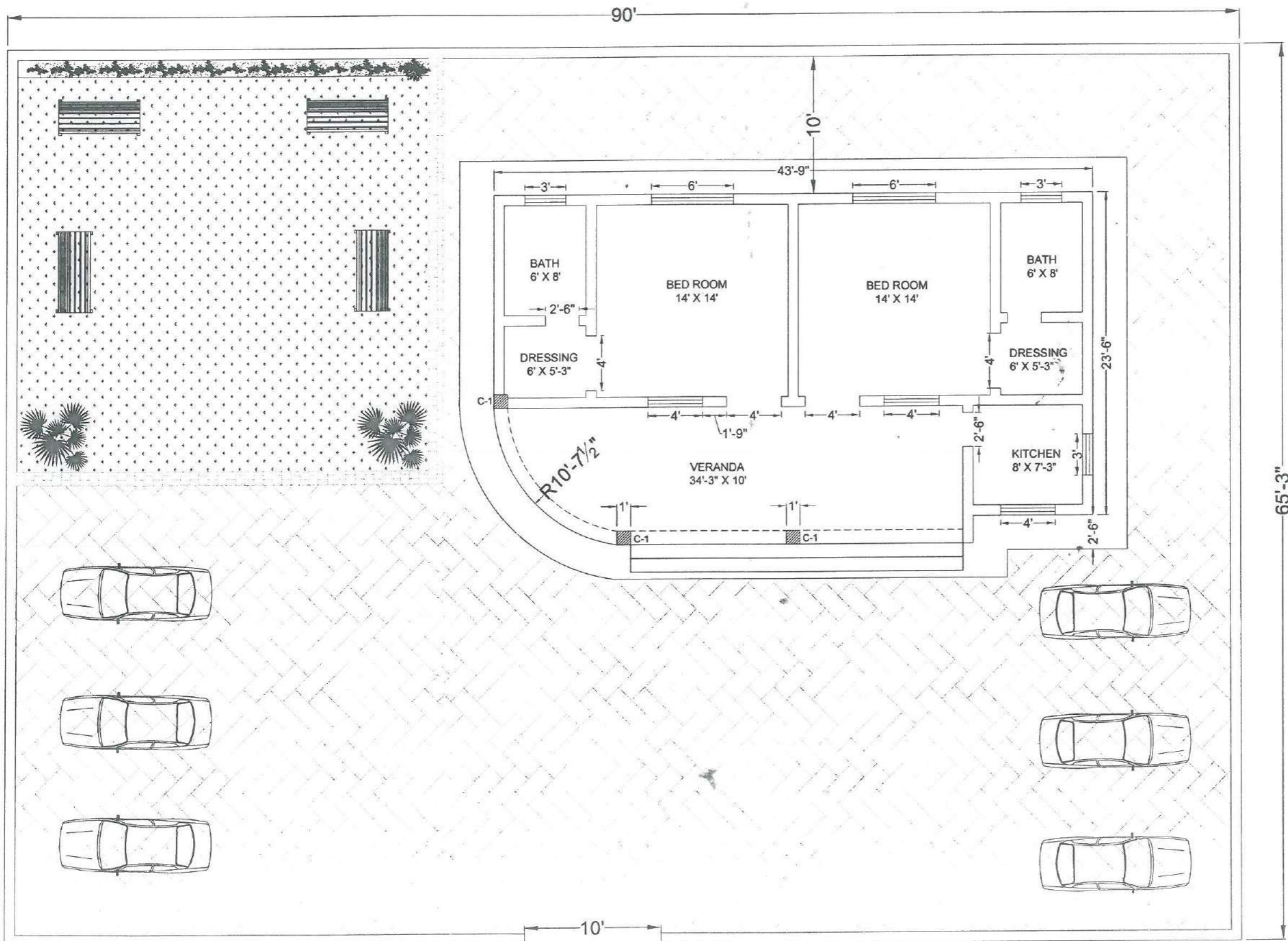

S.NO.	DATE	DESCRIPTIONS	CHECK
DIRECTORATE GENERAL SMALL DAMS IRRIGATION DEPARTMENT KHYBER PAKHTUNKHAWA			
SMALL DAM PROJECT			
SUMARI PAYAN DAM PROJECT CHOWKIDAR HUT PLAN			
 PAKISTAN ENGINEERING SERVICES (PVT.) LTD. 7 - B, COMMERCIAL AREA, PHASE - V, D.H.A. LAHORE.			
DRAFTER: DESIGNED: CHECKED: APPROVED:	FARDOO ALI ADNAN MANZOOR ASHFAQ ALI	DATE: DRAWING NO. SPD-CH-12	REV. NO. -

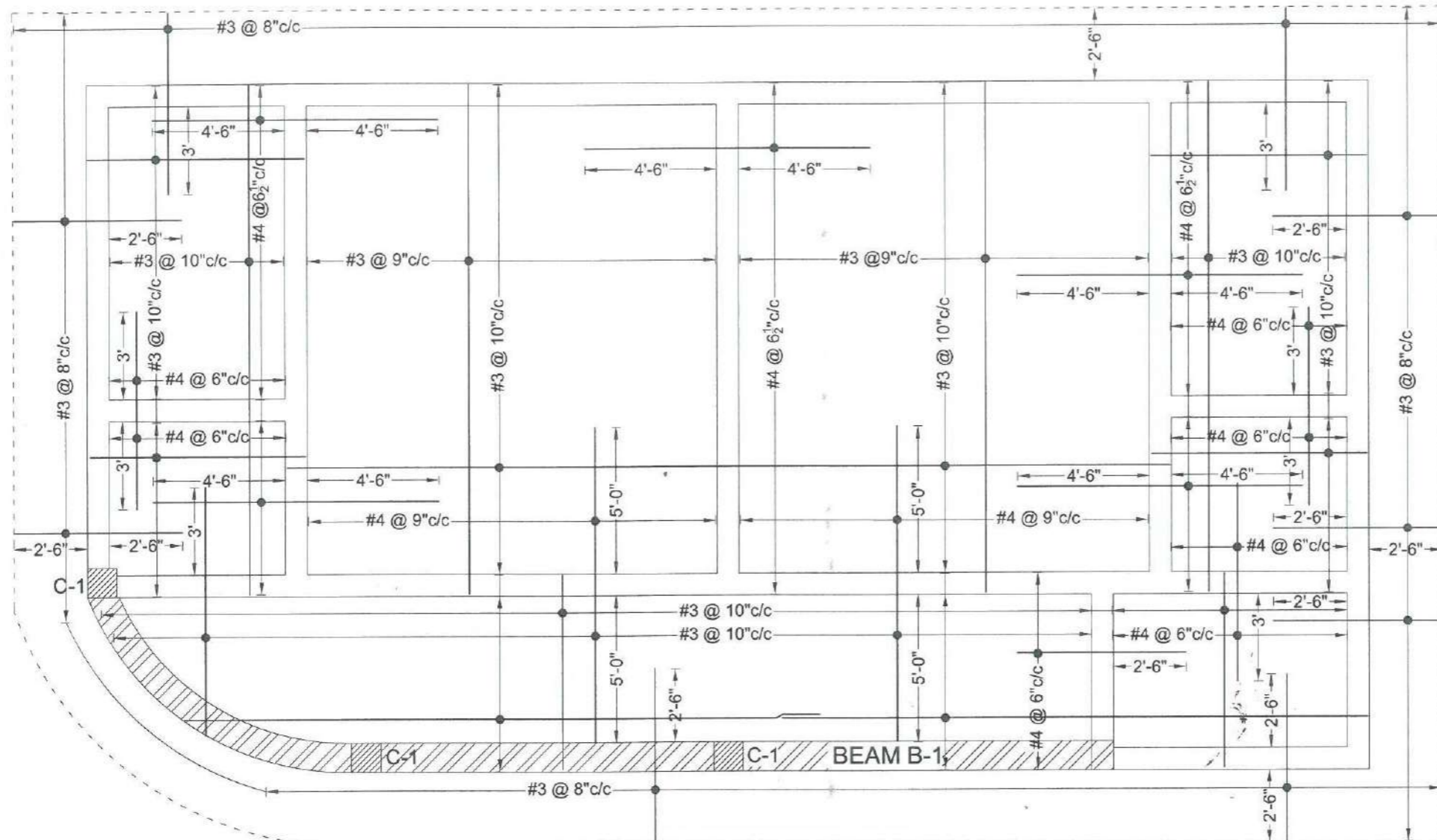

NOTE:-
1:- ALL LEVEL AND DIMENSIONS ARE IN FEET

SLAB STEEL DETAIL
SLAB THICKNESS 5"

SHEET 2 OF 3

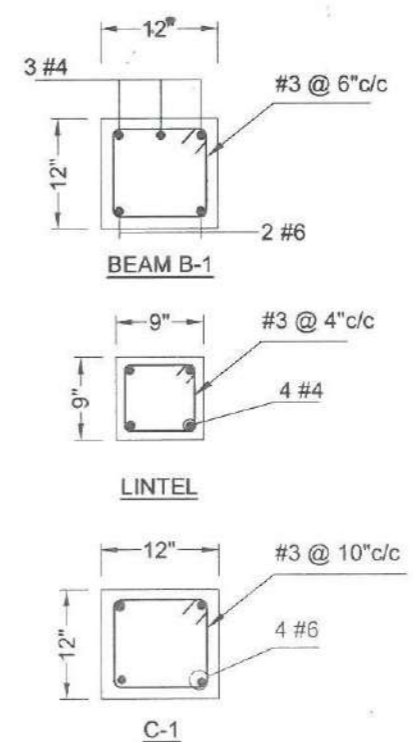
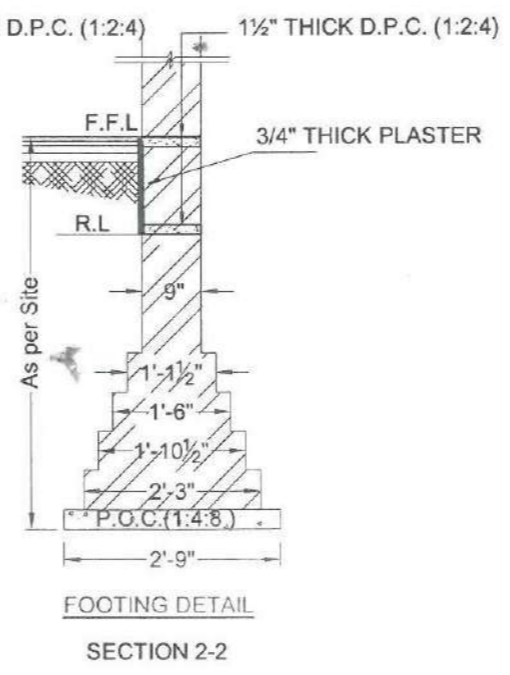
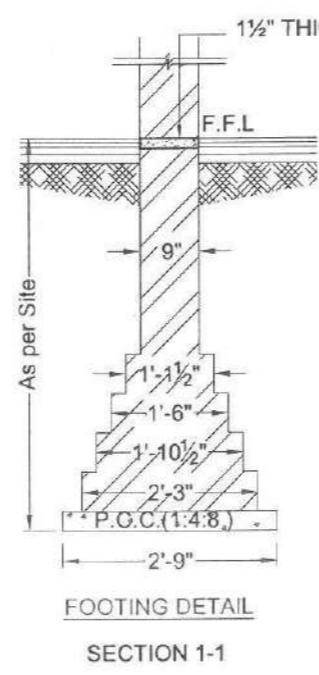
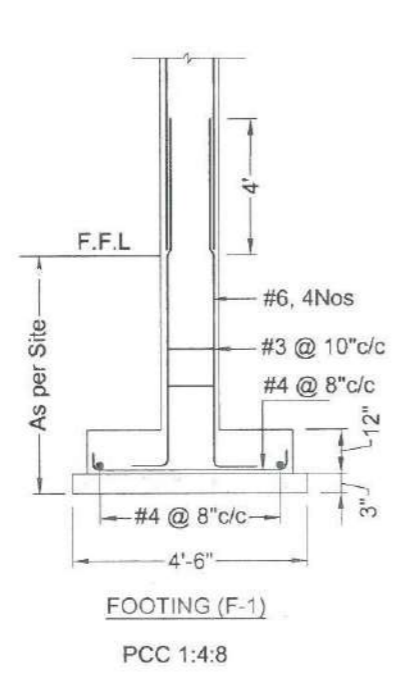

S.NO.	DATE	DESCRIPTIONS	CHECK
DIRECTORATE GENERAL SMALL DAMS IRRIGATION DEPARTMENT KHYBER PAKHTUNKHAWA			
SMALL DAM PROJECT			
SUMARI PAYAN DAM PROJECT CHOWKIDAR HUT REINFORCEMENT DETAIL			
PAKISTAN ENGINEERING SERVICES (PVT.) LTD. 7 - B, COMMERCIAL AREA, PHASE - V, D.H.A, LAHORE.			
DESIGNED BY:	FAROOQ ALI	DATE: 05-09-2023	REV. No
CHECKED BY:	ADMAN MANZOOR	DRAWING NO.	
APPROVED BY:	ASHFAQ ALI	CH-01	
	COL. AEBAS H. NADY		

NOTE:-
1:- ALL LEVEL AND DIMENSIONS ARE IN FEET

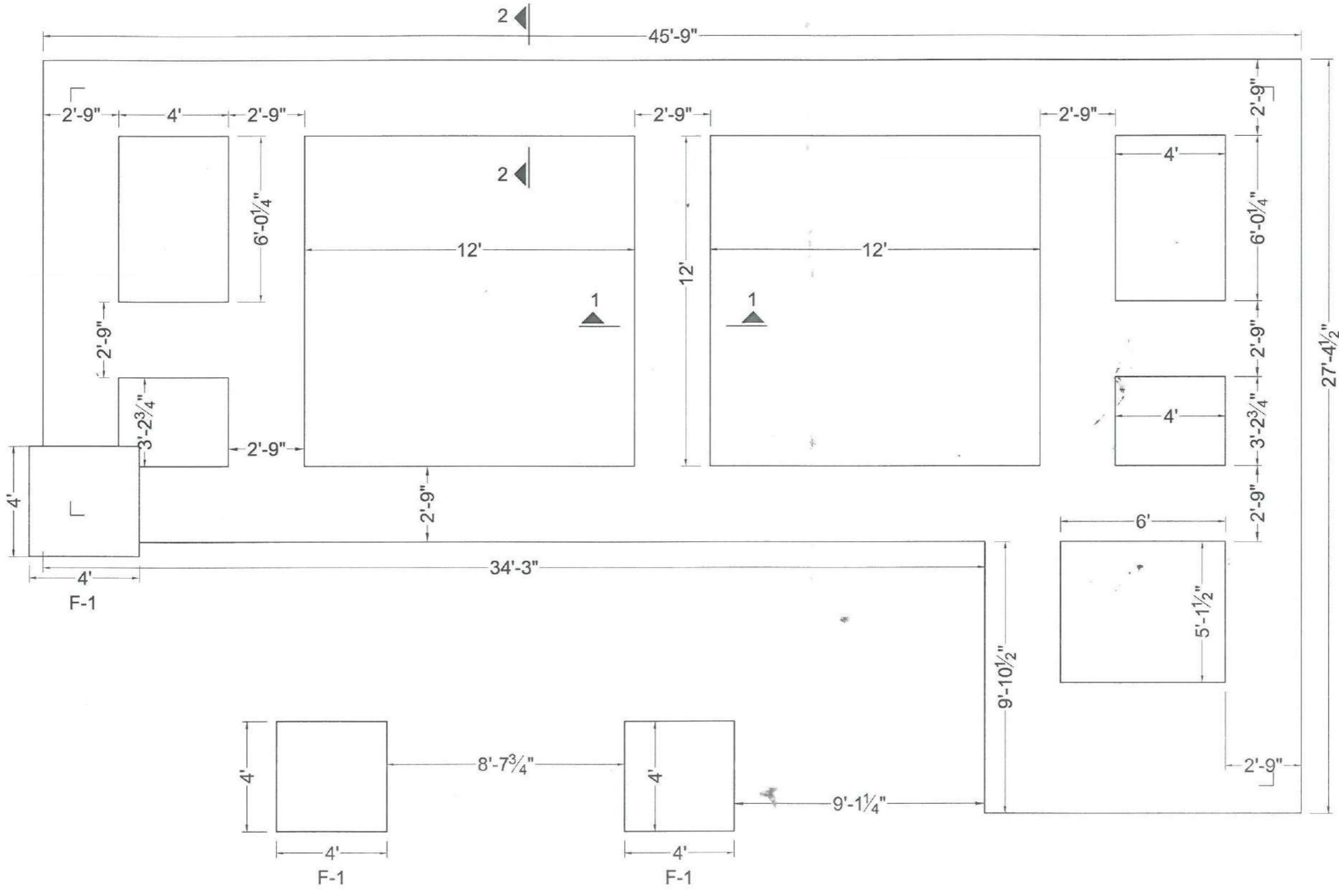

SHEET 3 OF 3



S. NO.	DATE	DESCRIPTIONS	CHECK
DIRECTORATE GENERAL SMALL DAMS IRRIGATION DEPARTMENT KHYBER PAKHTUNKHAWA			
SMALL DAM PROJECT			
SUMARI PAYAN DAM PROJECT CHOWKIDAR HUT EXCAVATION PLAN			
PAKISTAN ENGINEERING SERVICES (PVT.) LTD. 7 - B, COMMERCIAL AREA, PHASE - V, D.H.A, LAHORE.			
DESIGNED BY:	FAROOQ ALI	DATE:	06-09-2023
DESIGNED:	ADNAN MANZOOR	DRAWING NO.	
CHECKED:	ASHFAQ ALI		
APPROVED:	COL. ABBAS H. NAQVI	CH-01	

**SUMARI PAYAN DAM PROJECT
DISTRICT KOHAT
Summary of Cost**

Sr. No.	Description	Amount Rs. (Million)
A.	WORKS	
i.	Dam Embankment	1,021.213
ii.	Spillway	1,103.368
iii.	Intake & Outlet Structure	58.918
iv	Irrigation System Including affiliated Structures	246.815
v	Relocation of Road	226.568
vi	Relocation of Police Post & Construction of Inspection Hut	10.553
	Total (A)	2,667.433

**SUMARI PAYAN DAM PROJECT
DISTRICT KOHAT
BILL OF QUANTITIES**

Bill No. 1: Dam Embankment						
Item	MRS 2025 (1st Bi Annual) Item Code	Description	Unit	Rate (Rs)	Quantity	Amount (Rs.)
1.1	16-74-a	Bailing out standing water by Mechanical mean.	M ³	38.6	10,000.00	386,000.00
1.2	03-62	Clearing and grubbing by mechanical means	M ²	38.4	55,310.42	2,123,920.13
1.3 i)	03-78-a	Excavation for core trench of Dam Embankment/Spillway/Intake & Outlet Structure and Irrigation System upto a minimum depth of 35 ft in shingle gravel including removing of excavated material by machinery in 1.5 KM radius	M ³	469.64	15,008.39	7,048,540.28
1.3 ii)	03-78-b	Excavation for core trench of Dam Embankment/Spillway/Intake & Outlet Structure and Irrigation System upto design depth in Soft Rock/Shale requiring 20% blasting i/c removing of material from outside of the structure area lead upto 1.5 KM	M ³	1,014.77	66,631.15	67,615,289.33
1.3 iii)	03-78-c	Excavation for core trench of Dam Embankment/Spillway/Intake & Outlet Structure and Irrigation System upto design depth in Medium Hard Rock requiring 50% blasting i/c removing of material from outside of the structure area lead upto 1.5 KM	M ³	1,548.99	22,347.32	34,615,777.24
1.4	03-74	Provide , Place & compact shoulder material (sandy / silty gravel) in Dam Embankment, of specified grading, leveling / dressing i/c haulage for obtaining of 95% modified AASHTO dry density	M ³	673.1	283,166.51	190,599,377.88
1.4 (ii)	03-74 (Minimum Effort)	Provide , Place & compact shoulder material (sandy / silty gravel) in Dam Embankment, of specified grading, leveling / dressing i/c haulage for obtaining of 95% modified AASHTO dry density	M ³	269.24	215,750.00	58,088,530.00
1.5	03-73	Provide, place and compact impervious clay core in dam embankment of specified grading, permeability i/c leveling dressing and haulage obtaining 95% modified AASHTO dry density i/c 1.5 KM lead	M ³	847.55	147,784.27	125,254,558.04
1.6	03-75	Provide , Place & compact Fine Filter in chimney drain vertical / horizontal on downstream of clay core	M ³	3,257.44	28,351.79	92,354,254.82
1.7	03-76	Provide , Place & compact Coarse Filter (well graded gravel) in chimney drain vertical / horizontal on downstream of fine filter i/c leveling, moistening etc	M ³	1,914.95	99,603.72	190,736,143.61
1.8	28-05	Supply & fix boundry pillars in position, including digging pits	Nos.	1,024.00	100.00	102,400.00
1.9	28-17-b	Providing and Fixing barbed wire fencing with 4 horizontal & 2 cross wires : With PCC 1:4:8 base 12"x12"x21"	M	2,441.11	150.00	366,166.50
1.10	Market Rate	P&F Surface Marker	Nos.	5,000.00	15.00	75,000.00
1.11	19-28-a	Providing and Laying stone pitching for top layer only : On slope (Upstream Slope)	M ³	5,965.99	15,485.60	92,386,904.91
1.11(i)	19-28-a	Providing and Laying stone pitching for top layer only : On slope (Upstream Slope Labour Rate)	M ³	3,663.19	5,161.82	18,908,709.09
1.12	19-28-a	Providing and Laying stone pitching for top layer only : On slope (Down stream Slope)	M ³	5,965.99	7,755.77	46,270,816.43
1.12(i)	19-28-a	Providing and Laying stone pitching for top layer only : On slope (Down stream Slope Labour Rate)	M ³	3,663.19	2,585.26	9,470,280.26
1.13	Market Rate	Drilling of 4" Dia bore hole for Grout Curtain.	M	4,500.00	4,358.42	19,612,890.00
1.14	03-09-d	Earth excavation in open cut upto 1.5m depth for drains, pipes etc & disposal : in Gravel & shingle	M ³	802.63	6,650.52	5,337,906.87

Bill No. 1: Dam Embankment						
Item	MRS 2025 (1 st Bi Annual) Item Code	Description	Unit	Rate (Rs)	Quantity	Amount (Rs.)
1.15	Market Rate	Providing And Filling Cement Slurry / Bentonite grout cutain through bore hole including pressure test.	Bag	4,209.00	4,550.00	19,150,950.00
1.17	28-27-c	Drilling by diamond drilling, holes of minimum 75 mm dia. vertical or at specified inclination using diamond core drilling bit, double barrel tube in masonry, concrete or rock including cost of all materials, machinery, labour, water, collection of core samples, logging & labelling samples, supplying wooden core box and re-drilling in case of collapse of sides etc. complete. excluding cost of mobilization & demobilization. (For depth 0 to 50 m and inclined at 0 to 10 vertically downward)	m	17,631.76	108.00	1,904,230.08
1.18	24-01-a	Mobilization of plant, equipment and camping arrangements etc & demobilization after completion	Job	76,186.66	1.00	76,186.66
1.20	24-43	Providing and lowering Piezometer 1.25" GI Pipe including all accessories	m	1,904.34	108.00	205,668.72
1.21	06-05-f	Plain Cement Concrete including placing, compacting, finishing & curing (Ratio 1:2:4)	M ³	17,035.28	157.55	2,683,924.76
1.22	25-30-a	Providing and fixing steel grated doors, complete with locking arrangement, angle iron frame 2"x2"x3/8" and 3/4" round bars 4" center to center.	M ²	28,006.49	25.00	700,162.25
1.23	Market Rate	Telemetry Rain Guage	No.	1,500,000	1.00	1,500,000.00
Sub-Total A						987,574,587.87
Rs in Million						987.575
Bill No. 1: Electrification of Dam Embankment (Solar System)						
Item No	MRS 2025 (1 st Bi Annual) Item Code	Description	Unit	Rate (Rs)	Quantity	Amount (Rs.)
1.24	Market Rate	Construction of foundation for pole including cost of pit excavation, 1:2:4 RCC 450mm x 450mm x 1830mm along with (4 No Electro-plated galvanized J-bolts dia=25mm, length=1m with L-Bend=150mm) having at least 150mm threads with double Nuts/double Washers) complete in all respect	Nos	25,000.00	10	250000.00
1.25	Market Rate	P/I of Road light pole hot dipped galvanized , 4 meters long round conical overall thickness 4mm, single arms (1 m ,dia 2" ,thickness 3 mm), base dia 120 mm and top dia 70 mm with base plate size (400mm x 400mm x 20mm) along with stiffners (100mm x 200mm x 20mm), complete in all respect as shown in the drawings and as per instructions of Engineer in charge.	Nos	35,000.00	10	350000.00
1.26	26-01-d-01	Supply and Erection of Solar PV Module (Solar Panel) Mono-crystalline A-Grade (per Watt) (As per Approved Specifications)	watts	44.34	5000	221700.00
1.27	26-01-c-02	Supply and Erection of pole mounted SMD type light road light fixture in Aluminium dia cast body with corrosion resisted powder coated finish (60-70 watts) with 12/24V DC LED	Nos	16,555.00	10	165550.00
1.28	Market Rate	Flexible 1.5" dia PVC pipe for 4.0 mm ² copper cable through the pole for providing extra insulation to avoid Power loss	M	1,125.00	14	15750.00
1.29	24-18-b-01	Providing, laying, cutting, jointing, testing and disinfecting UPVC pressure pipeline in trenches (conforming to BS 3505 manufactured) jointed with socket, elbow, tee, bend and plug bend etc.manufactured by the respective manufacturer complete as per specifications UPVC Pressure Pipes Class C (9 Bar) except excavation. 2" NPS	M	546.81	150	82021.50
1.3	26-01-g-10	Supply and Erection 2x6 sq.mm flexible copper cable	M	940.11	150	141016.50
1.31	15-47-c	Wiring of main & sub-main in 2 single core PVC insulated & sheathed cable : 7/0.044"	M	1,148.77	150	172315.50
1.32	15-47-b	Wiring of main & sub-main in 2 single core PVC insulated & sheathed cable : 7/0.029"	M	753.13	150	112969.50
1.33	Market Rate	Lithium ion Batteris	Nos	600,000.00	2	1200000.00
1.34	Market Rate	Provision of Inverter 48 volt 5 KVA	Nos	600,000.00	1	600000.00
1.35	Market Rate	Mounting structure(as per system need	job	50,000.00	1	50000.00
1.36	Market Rate	Provision of Control Room for batteries, Inverter, etc having ventilation and free from water flow in all direction including 18 inch high PCC Bed from ground with locking door(14*8*8)	Job	200,000.00	1	200000.00
1.37	Market Rate	Installation & Transportation	Nos	200,000.00	1	200000.00
1.38	Market Rate	AC/DC Breakers and Allied Accessories	Job	100,000.00	1	100000.00
1.39	15-75-a	Supply and Erection cubical type factory fabricated floor/wall mounting steel main board comp. : on Surface	Job	32,800.57	1	32800.57
Sub Total B						3,894,123.570
Sub Total A						987,574,587.873
Grand Total (A+B)						991,468,711.443
Grand Total Bill No. 1 including Area Cost Factor for Kohat @ 1.03						1,021,212,772.786
Grand Total (in Rs. Million)						1,021.213

Bill No. 2: Spillway & Spill Channel						
Item	MRS 2025 (1st Bi Annual) Item Code	Description	Unit	Rate (Rs)	Quantity	Amount (Rs.)
2.1	03-78-a	Excavation for core trench of Dam Embankment/Spillway/Intake & Outlet Structure and Irrigation System upto a minimum depth of 35 ft in shingle gravel including removing of excavated material by machinery in 1.5 KM radius	M ³	469.64	31,126.01	14,618,019.34
2.1 i)	03-78-b	Excavation for core trench of Dam Embankment/Spillway/Intake & Outlet Structure and Irrigation System upto design depth in Soft Rock/Shale requiring 20% blasting i/c removing of material from outside of the structure area lead upto 1.5 KM	M ³	1,014.77	360,764.11	366,092,595.90
2.1 ii)	03-78-c	Excavation for core trench of Dam Embankment/Spillway/Intake & Outlet Structure and Irrigation System upto design depth in Medium Hard Rock requiring 50% blasting i/c removing of material from outside of the structure area lead upto 1.5 KM	M ³	1,548.99	49,750.00	77,062,252.50
2.2	06-07-d-02	Reinforced cement concrete work as in dams, spillways, weirs, barrages, cross drainage works and other hydraulic structures using crushed stone aggregate(screening & washing) and coarse sand i/c costof all labour and material and all kinds of form works, moulds, shuttering lifting/pumping, curing, rendering and finishing the exposed surface, cast in situ/precast excluding the cost of steel reinforcement and labour for bending binding also excludig cost of additives which have to bepaid separately. (1:1.5:3)	M ³	22,175.81	10,994.86	243,819,926.34
2.3	06-08-b	Supply & fabricate M.S. reinforcement for cement concrete (Hot rolled deformed bars Grade 60)	Tonne	306,713.50	750.00	230,035,125.00
2.4	06-05-f	Plain Cement Concrete including placing, compacting, finishing & curing (Ratio 1:2:4)	M ³	17,035.28	5,314.76	90,538,492.87
2.5	06-05-i	Plain Cement Concrete including placing, compacting, finishing & curing (Ratio 1:4:8)	M ³	12,340.56	1,780.96	21,978,035.00
2.6	19-28-b	Providing and Laying stone pitching for top layer only : On level	M ³	5,072.53	584.09	2,962,799.71
2.7	Market Rate	Relief holes 4" dia in Medium Hard Rock.	M ³	4,500.00	1,592.50	7,166,250.00
2.8	03-76	Provide, Place & Compact Coarse Filter (well graded gravel) in chimney drain vertical / horizontal on downstream of fine filter (shrouding material under spillway)	M ³	1,914.95	4,550.00	8,713,022.50
2.9	24-40	Supplying and Fixing PVC Water Stopper 8" wide 3/8" thick. Providing and fixing PVC water stopper 8" wide 3/8" thick in verticle (Wall/Column) or horizontal (Floor/Slab expansion joint including cutting and jointing complete in all respects.	M	736.90	799.50	589,151.55
2.10	Market Rate	Providing and Fixing #8 anchor Bars including cost of steel, drilling and grouting, complete in all respects in specified areas as per the construction drawings or as directed by the engineer in charge.	R.M	5,215.77	1,336.07	6,968,634.95
2.11	Market Rate	PVC 4" Dia Perforated Pipe.	M	650.00	1,056.00	686,400.00
Total Bill No. 02						1,071,230,705.67
Total Bill No. 2 including Area Cost Factor for Kohat @ 1.03						1,103,367,626.84
Rs in Million						1,103.37

Bill No. 3: Intake/Outlet Structure						
Item	MRS 2025 (1st Bi Annual) Item Code	Description	Unit	Rate (Rs)	Quantity	Amount (Rs.)
3.1	03-78-a	Excavation for core trench of Dam Embankment/Spillway/Intake & Outlet Structure and Irrigation System upto a minimum depth of 35 ft in shingle gravel including removing of excavated material by machinery in 1.5 KM radius	M ³	469.64	912.266	428,436.75
3.1 i)	03-78-b	Excavation for core trench of Dam Embankment/Spillway/Intake & Outlet Structure and Irrigation System upto design depth in Soft Rock/Shale requiring 20% blasting i/c removing of material from outside of the structure area lead upto 1.5 KM	M ³	1,014.77	2280.666	2,314,351.22
3.1 ii)	03-78-c	Excavation for core trench of Dam Embankment/Spillway/ Intake & Outlet Structure and Irrigation System upto design depth in Medium Hard Rock requiring 50% blasting i/c removing of material from outside of the structure area lead upto 1.5 KM	M ³	1,548.99	1368.399	2,119,637.10
3.2	06-05-i	Plain Cement Concrete including placing, compacting, finishing & curing (Ratio 1:2:4)	M ³	17,035.28	455.173	7,753,997.80
3.3	06-07-d-02	Reinforced cement concrete work as in dams, spillways, weirs, barrages, cross drainage works and other hydraulic structures using crushed stone aggregate(screening & washing) and coarse sand i/c costof all labour and material and all kinds of form works, moulds, shuttering lifting/pumping, curing, rendering and finishing the exposed surface, cast in situ/precast excluding the cost of steel reinforcement and labour for bending binding also excludig cost of additives which have to bepaid separately. (1:1.5:3)	M ³	22,175.81	479.700	10,637,736.06
3.4	06-08-b	Supply & fabricate M.S. reinforcement for cement concrete (Hot rolled deformed bars Grade 60)	Tonne	306,713.50	37.700	11,563,098.95
3.5	06-05-i	Plain Cement Concrete including placing, compacting, finishing & curing (Ratio 1:4:8)	M ³	12,340.56	1,519.79	18,755,048.22
3.6	23-03-a-07	Providing & laying R.C.C. pipe sewers, moulded with cement concrete 1:1-1/2:3 conforming to ASTM specification C-76-79, Class II, Wall B, including carriage, lowering in trenches to correct alignment and grade, jointing with rubber ring, cutting pipes where necessary, testing, etc. complete:- 30" i/d, Wall thickness 3.5"	M	9,279.00	120.445	1,117,609.16
3.7	Market Rate	Supply and Fix steel trash rack.	Sqm	4000	10	40,000.00
3.8	Market Rate	Providing and Placing 2ft Dia Gate valve at outlet of conduit with all accessories.	Nos	900,000	2	1,800,000.00
3.9	Market Rate	Providing and Placing 18" ft Dia Butterfly valve with all accessories.	Nos	250,000	1	250,000.00
3.10	Market Rate	Air relief valve 6" Dia	Nos	150,000	1	150,000.00
3.11	03-67-c	Sturctural Backfilling using Common Material Available at Site	M ³	544.30	500	272,150.00
Total Bill No. 03						57,202,065.250
Total Bill No. 3 including Area Cost Factor for Kohat @ 1.03						58,918,127.21
Rs in Million						58.918

Bill No. 4: Irrigation System including Affiliated Structures						
Item	MRS 2025 (1 st Bi Annual) Item Code	Description	Unit	Rate (Rs)	Quantity	Amount (Rs.)
MAIN CANAL RD 0+000 to RD 19+000						
4.1	03-78-a	Excavation for core trench of Dam Embankment/Spillway/Intake & Outlet Structure and Irrigation System upto a minimum depth of 35 ft in shingle gravel including removing of excavated material by machinery in 1.5 KM radius	M ³	469.64	47,308.34	22,217,886.69
4.1 i)	03-78-b	Excavation for core trench of Dam Embankment/Spillway/Intake & Outlet Structure and Irrigation System upto design depth in Soft Rock/Shale requiring 20% blasting i/c removing of material from outside of the structure area lead upto 1.5 KM	M ³	1,014.77	15,769.45	16,002,359.88
4.1 ii)	03-78-c	Excavation for core trench of Dam Embankment/Spillway/ Intake & Outlet Structure and Irrigation System upto design depth in Medium Hard Rock requiring 50% blasting i/c removing of material from outside of the structure area lead upto 1.5 KM	M ³	1,548.99	10,512.96	16,284,475.25
4.1 iii)	03-77	Excavation for core trench of Dam Embankment/Spillway/ Intake & Outlet Structure and Irrigation System upto a minimum depth of 35 ft in common soil including removing of excavated material by machinery in 1.5 KM radius	M ³	440.32	31,538.89	13,887,204.20
4.2	06-05-f	Plain Cement Concrete including placing, compacting, finishing & curing (Ratio 1:2:4)	M ³	17,035.28	186.55	3,178,011.61
4.3	06-05-i	Plain Cement Concrete including placing, compacting, finishing & curing (Ratio 1:4:8)	M ³	12,340.56	72.46	894,227.65
4.4	03-67-c	Structural backfilling using common material available at site	M ³	544.30	32,903.66	17,909,461.81
4.5	17-01-a	Formation, dressing and preparing sub-grade in bed	M ²	119.78	8,779.54	1,051,613.85
4.6	17-01-b	Formation, dressing and preparing sub-grade On slope	M ²	163.34	12,553.25	2,050,447.58
4.7	17-10-a-01	3" thick PCC lining, using washed screened & graded/crushed stone aggregate : in bed : Ratio 1:2:4	M ³	16,481.22	624.69	10,295,571.29
4.8	17-10-b-01	3" thick PCC lining, using washed screened & graded/crushed stone aggregate : On slope : Ratio 1:2:4	M ³	17,128.98	862.97	14,781,839.98
4.9	17-02	Stabilized layer of cement, sand mortar 1:3 2" thick on slope	M ²	514.78	20,946.45	10,782,812.97
4.10	06-23	Filling of expansion joints with bitumen,sand and saw dust in ratio 1:2:2	M	167.84	29,421.80	4,938,155.52
4.11	23-03-a-03	Providing & laying R.C.C. pipe sewers, moulded with cement concrete 1:1-1/2:3 conforming to ASTM specification C-76-79, Class II, Wall B, including carriage, lowering in trenches to correct alignment and grade, jointing with rubber ring, cutting pipes where necessary, testing, etc. complete:- 18" i/d, wall thickness 2.5".	M	4,475.90	1,066.75	4,774,657.12
4.12	06-07-d-03	Reinforced cement concrete work as in dams, spillways, weirs, barrages, cross drainage works and other hydraulic structures using crushed stone aggregate(screening & washing) and coarse sand i/c costof all labour and material and finishing the exposed surface, cast in situ/precast excluding the cost of steel reinforcement and labour for bending binding also excludig cost of additives which have to be paid separately. (1:2:4)	M ³	18,954.94	135.42	2,566,876.20
4.13	06-08-b	Supply & fabricate M.S. reinforcement for cement concrete (Hot rolled deformed bars Grade 60)	Tonne	306,713.50	10.83	3,322,809.07
4.14	06-07-d-05	Providing manhole size 24" x 18" (inside dimensions) as per approved design and specifications complete for 4" to 12" dia pipes upto 4 ft. (1.2 m) depth with 16" dia. Concrete Cover fixed in 4" thick RCC 1:2:4 slab (with 5 lbs per Cu.ft. or 80 kg/Cu.m of steel), burnt brick masonry walls 9" (225 mm) thick set in 1:3 cement sand mortar, 6" thick 1:3:6 cement concrete in foundation, 4" av. thickness 1:2:4 cement concrete in benching and 1/2" (13mm) thick cement sand plaster in 1:3 to all inside wall surfaces, channels and benching including making requisite number of main and branch channels but excluding the cost of excavation, back filling and disposal of excavated stuff.	Each	20,524.94	6.00	123,149.64
Sub-Total (i)						145,061,560.32

MINOR CANAL RD 0+000 to RD 9+300						
4.15	03-78-a	Excavation for core trench of Dam Embankment/Spillway/Intake & Outlet Structure and Irrigation System upto a minimum depth of 35 ft in shingle gravel including removing of excavated material by machinery in 1.5 KM radius	M ³	469.64	7,727.93	3,629,344.81
4.16	03-78-b	Excavation for core trench of Dam Embankment/Spillway/Intake & Outlet Structure and Irrigation System upto design depth in Soft Rock/Shale requiring 20% blasting i/c removing of material from outside of the structure area lead upto 1.5 KM	M ³	1,014.77	2,575.98	2,614,023.67
4.17	03-78-c	Excavation for core trench of Dam Embankment/Spillway/ Intake & Outlet Structure and Irrigation System upto design depth in Medium Hard Rock requiring 50% blasting i/c removing of material from outside of the structure area lead upto 1.5 KM	M ³	1,548.99	1,717.32	2,660,107.89
4.18	03-77	Excavation for core trench of Dam Embankment/Spillway/Intake & Outlet Structure and Irrigation System upto a minimum depth of 35 ft in common soil including removing of excavated material by machinery in 1.5 KM radius	M ³	440.32	5,151.95	2,268,507.95
4.19	06-05-f	Plain Cement Concrete including placing, compacting, finishing & curing (Ratio 1:2:4)	M ³	17,035.28	74.32	1,266,070.50
4.20	06-05-i	Plain Cement Concrete including placing, compacting, finishing & curing (Ratio 1:4:8)	M ³	12,340.56	276.90	3,417,063.33
4.21	03-67-c	Structural backfilling using common material available at site	M ³	544.30	6,818.37	3,711,241.44
4.22	17-11-f	Providing and laying Pre-cast parabolic segments, moulded with cement concrete 1:1-1/2:3, excluding carriage, lowering in water channels to correct alignment and grade, jointing, finishing where necessary, etc. complete in all respects:- Top width- 30" (760mm) & Total Depth- 21"(525mm)	M	8,219.52	1,828.71	15,031,124.66
4.23	17-11-e	Providing and laying Pre-cast parabolic segments, moulded with cement concrete 1:1-1/2:3, excluding carriage, lowering in water channels to correct alignment and grade, jointing, finishing where necessary, etc. complete in all respects:- Top width- 27" (675mm) & Total Depth- 19"(480mm)	M	7,103.17	1,005.79	7,144,303.87
4.24	NSI	Field Mobility Support for inspection and quality control	No.	13,547,610	1.00	13,547,610.00
Sub-Total (i)						55,289,398.11
Sub-Total A						200,350,958.43

SUMARI PAYAN DAM PROJECT
DISTRICT KOHAT
BILL OF QUANTITIES

Bill No.4 : Irrigation System including Affiliated Structures						
Item	MRS 2025 (1st Bi Annual) Item Code	Description	Unit	Rate (Rs)	Quantity	Amount (Rs.)
MAIN & MINOR CANAL (Affiliated Structures)						
I	Road Culverts = 3 Nos.					
1	03-78-a	Excavation for core trench of Dam Embankment / Spillway / Intake & Outlet Structure and Irrigation System upto a minimum depth of 35 ft in shingle gravel i/c removing of excavated material by machinery in 1.5 KM radius.	M ³	469.64	187.5	88,057.50
2	03-78-b	Excavation for core trench of Dam Embankment/Spillway /Intake & Outlet Structure and Irrigation System upto design depth in Soft Rock/Shale requiring 20% blasting i/c removing of material from outside of the structure area lead upto 1.5 KM	M ³	1014.77	78.975	80,141.46
3	06-05-h	Plain Cement Concrete including placing compacting finishing and curing complete (1:3:6).	M ³	13,983.72	10.569	147,793.94
4	06-07-d-03	Reinforced cement concrete work as in dams, spillways, weirs, barrages, cross drainage works and other hydraulic structures using crushed stone aggregate (screening & washing) and coarse and i/c cutoff all labour and material and all kinds of form works, moulds, shuttering lifting / pumping, curing, rendering and finishing the exposed surface, cast in situ/precast excluding the cost of steel reinforcement and labour for bending binding also excluding cost of additives which have to be paid separately. (Type C (1:2:4)	M ³	18,954.94	117	2,217,727.98
5	06-08-c	Supply & fabricate M.S. reinforcement for cement concrete (Hot rolled deformed bars Grade 40)	Tonne	303,008.50	2.925	886,299.86
6	19-29-b	Providing and Laying stone or spawl filling : On level	M ³	2,624.64	19.125	50,196.24
7	03-67-c	Structural Backfilling using common material available at site.	M ³	544.3	73.785	40,161.18
Sub-Total (I)						3,510,378.16
II	Drainage Crossing 09 Nos.					
1	03-78-a	Excavation for core trench of Dam Embankment / Spillway / Intake & Outlet Structure and Irrigation System upto a minimum depth of 35 ft in shingle gravel i/c removing of excavated material by machinery in 1.5 KM radius.	M ³	469.64	270	126,802.80
2	06-05-h	Plain Cement Concrete including placing compacting finishing and curing complete (1:3:6).	M ³	13,983.72	6.3	88,097.44
3	06-07-d-03	Reinforced cement concrete work as in dams, spillways, weirs, barrages, cross drainage works and other hydraulic structures using crushed stone aggregate (screening & washing) and coarse and i/c cutoff all labour and material and all kinds of form works, moulds, shuttering lifting / pumping, curing, rendering and finishing the exposed surface, cast in situ/precast excluding the cost of steel reinforcement and labour for bending binding also excluding cost of additives which have to be paid separately. (Type C (1:2:4)	M ³	18,954.94	90	1,705,944.60
4	06-08-c	Supply and Fabricate Ms Reinforcement for cement concrete deformed bar G-40.	Tonne	303,008.50	2.8125	852,211.41
5	19-29-b	Providing and Laying stone or spawl filling : On level	M ³	2,624.64	135	354,326.40
6	03-67-c	Structural Backfilling using common material available at site.	M ³	544.3	76.5	41,638.95
7	23-03-a-07	Providing & laying R.C.C. pipe sewers, moulded with cement concrete 1:1-1/2:3 conforming to ASTM specification C-76-79, Class II, Wall B, including carriage, lowering in trenches to correct alignment and grade, jointing with rubber ring, cutting pipes where necessary, testing, etc.complete:- 30" i/d, Wall thickness 3.5"	m	9,279.00	78.75	730,721.25
Sub-Total (II)						3,899,742.84

Item	MRS 2025 (1 st Bi Annual) Item Code	Description	Unit	Rate (Rs)	Quantity	Amount (Rs.)
III	Syphon 02 No.					
1	03-78-a	Excavation for core trench of Dam Embankment / Spillway / Intake & Outlet Structure and Irrigation System upto a minimum depth of 35 ft in shingle gravel i/c removing of excavated material by machinery in 1.5 KM radius.	M ³	469.64	200.00	93,928.00
2	03-78-b	Excavation for core trench of Dam Embankment/Spillway/Intake & Outlet Structure and Irrigation System upto design depth in Soft Rock/Shale requiring 20% blasting i/c removing of material from outside of the structure area lead upto 1.5 KM	M ³	1014.77	50.00	50,738.50
3	06-05-h	Plain Cement Concrete including placing compacting finishing and curing complete (1:3:6).	M ³	13,983.72	10.00	139,837.20
4	06-07-d-03	Reinforced cement concrete work as in dams, spillways, weirs, barrages, cross drainage works and other hydraulic structures using crushed stone aggregate (screening & washing) and coarse and i/c cutoff all labour and material and all kinds of form works, moulds, shuttering lifting / pumping, curing, rendering and finishing the exposed surface, cast in situ/precast excluding the cost of steel reinforcement and labour for bending binding also excluding cost of additives which have to be paid separately. (Type C (1:2:4))	M ³	18,954.94	500.00	9,477,470.00
5	06-08-c	Supply and Fabricate Ms Reinforcement for cement concrete deformed bar G-40.	Tonne	303,008.50	30.00	9,090,255.00
6	19-29-b	Providing and Laying stone or spawl filling : On level	M ³	2,624.64	350.00	918,624.00
7	03-67-c	Structural Backfilling using common material available at site.	M ³	544.3	100.00	54,430.00
Sub-Total (III)						19,825,282.70
IV	Falls - 24 Nos.					
1	03-78-b	Excavation for core trench of Dam Embankment/Spillway/Intake & Outlet Structure and Irrigation System upto design depth in Soft Rock/Shale requiring 20% blasting i/c removing of material from outside of the structure area lead upto 1.5 KM	M ³	1014.77	642.88	652,371.28
2	06-05-h	Plain cement concrete including placing compacting finishing and curing complete (1:3:6).	M ³	13,983.72	36.00	503,413.92
3	06-07-d-03	Rienforced cement concrete work as in dams, spillways, weirs, barrages, cross drainage works and other hydraulic structure using crushed stone aggregate (screening & washing) and coarse and i/c cut off all labour and material and all kinds of form works, moulds, shuttering lifting / pumping, curing, rendering and finishing the exposed surface, cast in situ/precast excluding the cost of steel reinforcement and labour for bending binding also excluding cost of additives which have to be paid separatly.Type C (1:2:4).	M ³	18,954.94	192.00	3,639,348.48
4	03-67-c	Structure Backfilling using common material available at site.	M ³	544.30	3,000.00	1,632,900.00
5	06-08-c	Supply and Fabricate Ms Rienforcement for cement concrete deformed bar G-40	Tonne	303,008.50	7.68	2,327,105.28
Sub-Total (IV)						8,755,138.96

Item	MRS 2025 (1 st Bi Annual) Item Code	Description	Unit	Rate (Rs)	Quantity	Amount (Rs.)
V	Outlets : Tail Clusters = 2 Nos.					
1	03-78-a	Excavation for core trench of Dam Embankment / Spillway / Intake & Outlet Structure and Irrigation System upto a minimum depth of 35 ft in shingle gravel i/c removing of excavated material by machinery in 1.5 KM radius.	M ³	469.64	78.00	36,631.92
2	06-05-h	Plain Cement Concrete including placing compacting finishing and curing complete (1:3:6).	M ³	13,983.72	7.50	104,877.90
3	06-07-d-03	Reinforced cement concrete work as in dams, spillways, weirs, barrages, cross drainage works and other hydraulic structures using crushed stone aggregate (screening & washing) and coarse and i/c cutoff all labour and material and all kinds of form works, moulds, shuttering lifting / pumping, curing, rendering and finishing the exposed surface, cast in situ/precast excluding the cost of steel reinforcement and labour for bending binding also excluding cost of additives which have to be paid separately. (Type C (1:2:4))	M ³	18954.94	18.00	341,188.92
3	06-08-c	Supply and Fabricate Ms Reinforcement for cement concrete deformed bar G-40.	Tonne	303,008.50	2.25	681,769.13
4	19-29-b	Providing and Laying stone or spawl filling : On level	M ³	2624.64	15.00	39,369.60
Sub-Total (V)						1,203,837.47
VI	Irrigation Outlets = 08 Nos.					
1	03-78-a	Excavation for core trench of Dam Embankment / Spillway / Intake & Outlet Structure and Irrigation System upto a minimum depth of 35 ft in shingle gravel i/c removing of excavated material by machinery in 1.5 KM radius.	M ³	469.64	62.06	29,146.80
2	06-05-h	Plain cement concrete including placing compacting finishing and curing complete (1:3:6).	M ³	13,983.72	5.28	73,806.07
3	06-07-d-03	Rienforced cement concrete work as in dams, spillways, weirs, barrges, cross drainage works and other hydraulic structure using crushed stone aggregate (screening & washing) and coarse and i/c cut off all labour and material and all kinds of form works, moulds, shuttering lifting / pumping, curing, rendering and finishing the exposed surface, cast in situ/precast excluding the cost of steel reinforcement and labour for bending binding also excluding cost of additives which have to be paid separatly.Type C (1:2:4).	M ³	18,954.94	39.00	739,242.66
4	06-08-c	Supply & fabricate M.S. reinforcement for cement concrete (Hot rolled deformed bars Grade 40)	Tonne	303,008.50	4.00	1,212,034.00
5	19-29-b	Providing and Laying stone or spawl filling : On level	M ³	2624.64	10.00	26,246.40
Sub Total (VI)						2,080,475.93
Total Cost of Affiliated Structures (I+II+III+IV+V+VI)						39,274,856
Sub-Total B						39,274,856.05
Sub-Total A						200,350,958.43
Total of Bill No. 04						239,625,814.48
Total Bill No. 4 including Area Cost Factor for Kohat @ 1.03						246,814,588.92
Grand Total Bill No. 4						246.81

SUMARI PAYAN DAM PROJECT

DISTRICT KOHAT

Bill No. 05: Relocation of Road

Item	MRS 2025 (1 st Bi Annual) Item Code	Description	Unit	Rate (Rs)	Quantity	Amount (Rs.)
EARTHWORK						
1	03-66-a	Roadway Excavation in Surplus / Unsuitable Common Material	M ³	725.74	29,677	21,537,752
2	03-66-c	Roadway Excavation in Surplus / Unsuitable Rock (Medium) Material requiring blasting	M ³	1,295.69	44,515	57,678,198
3	03-66-d	Roadway Excavation in Surplus / Unsuitable Rock (Soft) Material	M ³	849.61	84,192	71,530,691
SUB-BASE AND BASE COURSE						
4	03-70-c	Formation of Embankment from Borrow Excavation in Common Material including compaction Modified AASHTO 90% by power roller.	M ³	1,091.93	5,434	5,933,845
5	16-04-a	Granular Sub Base Course using Pit Run Gravel	M ³	2,490.09	2,500	6,225,225
6	16-05-b	Water Bound Macadam Base Course	M ³	4,112.82	1,200	4,935,384
SURFACE COURSE AND PAVEMENT						
7	16-09-a	Bitumenous Prime Coat	M ²	295.54	8,500	2,512,090
8	16-10-c	Triple bitumenous Surface Treatment	M ²	1,065.46	8,500	9,056,410
RETAINING WALLS						
9	03-67-a-i	Structural Excavation in Common Material	M ³	573.19	650	372,574
10	03-67-c	Structural backfill using Common Material available at site.	M ³	544.3	300	163,290
11	06-05-l	Plain Cement Concrete including placing, compacting, finishing & curing (Ratio 1:4:8)	M ³	12,340.56	190	2,344,706
12	08-01-d-03	Random rubble masonry in foundn. & plinth in cement, sand mortar : Ratio 1:6	M ³	11,472.35	800	9,177,880

Item	MRS 2025 (1 st Bi Annual) Item Code	Description	Unit	Rate (Rs)	Quantity	Amount (Rs.)
CULVERT						
13	03-67-a-i	Structural Excavation in Common Material	M ³	573.19	1,500	859,785
14	03-67-c	Structural backfill using Common Material available at site.	M ³	544.3	1,500	816,450
15	06-05-f	Plain Cement Concrete including. placing compacting. finishing & curing (ratio 1:2:4)	M ³	17,035.28	300	5,110,584
16	06-05-l	Plain Cement Concrete including. placing compacting. finishing & curing (ratio 1:4:8) in foundation	M ³	12,340.56	300	3,702,168
17	06-07-a-03	RCC in roof slab, beam, column & other structural members, insitu or precast. Type C (1:2:4)	M ³	19,446.34	100	1,944,634
18	06-08-b	Supply & fabricate M.S. reinforcement for cement concrete (Hot rolled deformed bars Grade 60)	tonn	306,713.50	10	3,067,135
19	06-05-h	Plain Cement Concrete including placing, compacting, finishing & curing (Ratio 1:3:6)	M ³	13,983.72	50	699,186
20	19-27	Providing and Laying stone pitching with hammer dressed stones on surface, laid in courses	M ³	5,072.53	100	507,253
21	16-29-b-i	Reinforced Concrete Pipe Culvert (AASHTO M-170) Dia:610mm	M	7,594.86	400	3,037,944
22	08-01-d-03	Random rubble masonry in foundn. & plinth in cement, sand mortar : Ratio 1:6	M ³	11,472.35	2,000	22,944,700

Item	MRS 2025 (1 st Bi Annual) Item Code	Description	Unit	Rate (Rs)	Quantity	Amount (Rs.)
DRAINAGE						
23	03-67-a-i	Structural Excavation in Common Material	M ³	573.19	500	286,595
24	03-67-c	Structural backfill using Common Material available at site	M ³	544.3	200	108,860
25	06-05-l	Plain Cement Concrete including placing, compacting, finishing & curing (Ratio 1:4:8)	M ³	12,340.56	100	1,234,056
26	06-05-f	Plain Cement Concrete including placing, compacting, finishing & curing (Ratio 1:2:4)	M ³	17,035.28	100	1,703,528
27	08-01-d-03	Random rubble masonry in foundn. & plinth in cement, sand mortar : Ratio 1:6	M ³	11,472.35	350	4,015,323
Total Bill No. 05						219,968,494
Total Bill No. 5 including Area Cost Factor for Kohat @ 1.03						226,567,548
Rs in Million						226.568

SUMARI PAYAN DAM PROJECT
DISTRICT KOHAT
Bill No. 06 Relocation of Police Post & Construction of
Inspection Hut

Item	MRS 2025 (1st Bi Annual) Item Code	Description	Unit	Rate (Rs)	Quantity	Amount (Rs.)
1	03-25-d	Excavation in foundation of building bridges etc complete in Shingle gravel.	M ³	485.96	480.23	233,372.57
2	06-03-a	Cement concrete (brick/stone ballast, 1.5" to 2"/nullah shingle well graded and cleaned) in foundation & plinth (Ratio(1:3:6)	M ³	12,660.84	20.30	257,015.05
3	07-04-a-03	Pacca brick work in foundation and plinth in cement, sand mortar 1:4.	M ³	17,062.81	25.10	428,276.53
4	06-26-a-02	Damp proof course of cem. conc. 1:2:4 including bitumen coat, 1 layer polythene & 1 coat bitumen (2" thick)	M ²	1,510.02	75.60	114,157.51
5	07-05-a-03	1st class brick work in ground floor Cement, sand mortar 1:4	M ³	18,128.70	130.54	2,366,520.50
6	06-07-a-03	RCC in roof slab, beam, column & other structural members, insitu or precast. (1:2:4)	M ³	19,446.34	60.48	1,176,114.64
7	06-08-c	Supply & fabricate M.S. reinforcement for cement concrete (Hot rolled deformed bars Grade 40)	Tonne	303,008.50	6.42	1,945,314.57
8	12-08-b	First class deodor wood wrought joinery in door and window etc. complete 1-3/4" thick.	M ²	32,136.59	10.41	334,507.26
9	10-15-h	Provie & lay topping of concrete 1:2:4 including surface finishing & dividing in panels 3" thick.	M ²	2,078.66	89.31	185,649.84
10	11-12-b	Cement plaster 1:6, upto 20' height 1/2" thick.	M ²	484.76	687.05	333,055.35
11	13-05-a	French polishing complete on new work.	M ²	1,389.34	20.82	28,923.06
12	11-21-a-03	Distember New surface: three coats.	M ²	231.95	446.68	103,607.93
13	12-65-a-06	Supply and Fixing aluminium door/window, Sliding Window Premium model (2.00 mm gauge) 4" section	M ²	1,061.01	10.92	11,586.31
14	12-70-a	Supply and Fixing MS Sheet 16 guage(10" x 2") box type chowkats including fixing in position with all charges for Hold fast, Hinges and Painting etc	M	2,139.62	26.21	56,082.69
15	22616.0	MS flat 1/2"x1/8" grill in windows of approved design	M ²	3,736.91	10.92	40,807.34
16	10-39-a	Glazed tile 1/4" thick dado jointed in white cement complete : Ceramic Tile - 6"x6" white	M ²	1,361.14	0.20	276.92
17	10-49-b	Providing and Laying trevera marble fine dressed stone flooring on surface in white cement complete 12"x24"x3/4" thick	M ²	517.23	1.06	547.30
18	10-26-a-i	Provide & lay marble fine dressed stone flooring on surface in white cement complete: 3/8" thick 12 x 12 Super Sunny White Marble	M ²	2,748.30	0.10	266.25
19	10-50-b	Providing and Fixing Ceramic Floor Tiles of approved quality of Size 20" x 20"	M ²	3,676.22	0.13	474.86
20	14-03-a	Providing and fitting glazed earthenware water closet (WC), squatter type (orisa pattern) combined with foot rest. complete in all respects : White	Nos	4,106.76	1.00	4,106.76
21	4-05-a-06	Providing and Fixing glazed earthen ware wash hand basin (WHB) complete size 56x40 cm (22"x16"), including bracket set, waste coupling, complete in all respects: Colour with pedestal (Normal Quality)	Nos	5,116.13	1.00	5,116.13
22	14-18-a	Providing and fixing best quality 5mm glass shelf (60 x 13) cm 24"x5" complete: With chromium plated brackets & railing	Nos	1,349.98	1.00	1,349.98

SUMARI PAYAN DAM PROJECT
DISTRICT KOHAT
Bill No. 06 Relocation of Police Post & Construction of
Inspection Hut

Item	MRS 2025 (1st Bi Annual) Item Code	Description	Unit	Rate (Rs)	Quantity	Amount (Rs.)
23	14-17-d	Providing and fixing 22" x 16" looking mirror of Imported glass complete with Aluminum frame of standared size & c.p screws.	Nos	2,597.26	1.00	2,597.26
24	14-16-a	Providing and Fixing chromium plated (CP) towel rail complete: 60 cm (24") long and 2 cm (3/4") dia	Nos	1,347.25	1.00	1,347.25
25	14-15	Providing and Fixing CP (chromium plated) toilet paper holder complete	Nos	1,274.39	1.00	1,274.39
26	14-13	Providing and fixing choricum plated soap dish complete.	Nos	1,052.08	1.00	1,052.08
27	14-10-a	Providing and Fixing glazed earthen ware low down flushing cistern 3 gallons (13.63 Liters) capacity including bracket set, copper connection, etc. complete in all respects: White	Nos	9,091.55	1.00	9,091.55
28	14-06-a	Providing and Fixing stainless steel sink with drain board size (120 x 60 cm) 48"x24", including set of brackets, waste pipe etc - (Best Quality)	Nos	14,511.05	1.00	14,511.05
29	14-06-a	Providing and Fixing stainless steel sink with drain board size (120 x 60 cm) 48"x24", including set of brackets, waste pipe etc - (Best Quality)	Nos	14,511.05	1.00	14,511.05
30	14-26-b	Providing and fixing chorimum plated (CP) shower rose : Size 3/4"x6" (20mm x 150 mm) (Best Quality)	Nos	2,867.53	1.00	2,867.53
31	14-32-b	Providing and Fixing 'P' trap of approved quality including GI grating & PCC chamber 4" (100 mm) glazed	Nos	583.11	1.00	583.11
32	14-55-d	Providing and Fixing GI pipe & including specials complete 1" dia (light)	M	1,408.12	15.24	21,458.70
33	14-55-e	Providing and Fixing GI pipe & including specialscomplete: 3/4" dia (light)	M	1,065.36	18.29	19,482.35
34	14-55-f	Providing and Fixing GI pipe & including specials complete: 1/2" dia (light)	M	782.52	18.29	14,310.03
35	14-61-d	Providing and Fixing approved best quality cooking range with 3 burners, oven, hot case & roastary	Nos	35,080.94	1.00	35,080.94
36	14-69-a-01	Providing and fixing Fibre Glass , corrosion resistant, UV stablized WaterTank : 300 gallons	Nos	16,595.86	1.00	16,595.86
37	23-10	Septic Tank (int.Size: 7'x2'x5') complete.	Nos	37,758.60	1.00	37,758.60

SUMARI PAYAN DAM PROJECT
DISTRICT KOHAT
Bill No. 06 Relocation of Police Post & Construction of
Inspection Hut

Item	MRS 2025 (1st Bi Annual) Item Code	Description	Unit	Rate (Rs)	Quantity	Amount (Rs.)
38	23-11	Soakage Pit (6'dia x 15' deep) complete	Nos	32,607.04	1.00	32,607.04
39	23-01-a	Providing and laying R.C.C. pipe, moulded with cement concrete 1:1-1/2:3, with spigot, socket or collar joint, etc. including cost of reinforcement, conforming to B.S. 5911: Part-I, 1981 Class "L" including carriage, lowering in trenches to correct alignment and grade, jointing, cutting pipe where necessary, finishing and testing, etc. complete:- 4" dia:	M	1,072.84	15.00	16,092.60
40	14-37-a	Supply and Fixing cast iron (CI) manhole cover with frame etc (Heavy Type) of approved quality complete: 12" (300 mm) dia	Nos	2,121.31	1.00	2,121.31
41	14-28-a	Providing and fixing gun metal peet / gate valve (screwed) 32 mm (1-1/4") dia of approved quality.	Nos	1,963.52	1.00	1,963.52
42	14-39-a	Providing and Fixing brass stop/bib cock of approved quality: 1/2" (13 mm) dia	Nos	1,200.29	1.00	1,200.29
43	15-02-a-03	Supply and Erection PVC pipe for wiring purpose complete On surface including clamps etc: 1" i/d	M	188.82	15.00	2,832.30
44	15-45	Wiring of light/fan/call-bell point in 3/0.029" PVC insulated & sheathed cable on sahl wood strip	Nos	1,786.21	3.00	5,358.63
45	15-46	Wiring of 2/3-pin 5-Amp plug point in 3/0.029" PVC insulated & sheathed cable on sahl wood	Nos	1,214.97	3.00	3,644.91
46	15-69-a	Supply and Erection best quality exhaust fan complete with shutter & regulator : 12" sweep	Nos	4,167.05	3.00	12,501.15
47	15-68-c	Supply and Erection best quality AC ceiling fan complete with GI rod, canopy, blades & regulator : 56" sweep	Nos	10,148.81	3.00	30,446.43
48	15-75-b	Supply and Erection cubical type factory fabricated floor/wall mounting steel main board comp. : Recessed	M ²	33,481.14	3.00	100,443.42
49	15-36-i-11	Supply, installation, testing and commissioning of 1x160 Watt, Highbay LED light , complete in all respects.	Nos	24,764.52	5.00	123,822.60
50	Market rate	S/E tube light rod and choke complete 40 watt.	Nos	2,000.00	5.00	10,000.00
51	15-47-c	Wiring of main & sub-main in 2 single core PVC insulated & sheathed cable : 7/0.044"	M	1,148.77	27.43	31,511.52
52	14-80-a	Supply and fixing of 2.0 HP Monoblock water pump 1.5"x1.25" 3 stage model DE-S3 (Deen Pump) single phase for 150 ft head with all accessories	Nos	64,576.09	1.00	64,576.09
53	03_57	Leveling and Dressing and making lawns.	M ²	53.74	2,072.54	111,378.24
54	25-30-a	Providing and fixing steel grated doors, complete with locking arrangement, angle iron frame 2"x2"x3/8" and 3/4" round bars 4" center to center.	M ²	28,006.49	43.89	1,229,178.47
55	21245.0	Turfing of lawn with Dacca Grass	M ²	311.61	2,072.54	645,823.83
Total Bill No. 06						10,245,153.45
Total Bill No. 6 including Area Cost Factor for Kohat @ 1.03						10,552,508.05
Rs in Million						10.55